

# CLIMATE CHANGE RESEARCH

REPORT 3/1995

CLIMEX project:  
Whole catchment manipulation  
of CO<sub>2</sub> and temperature



# NIVA - REPORT

Norwegian Institute for Water Research  NIVA

Report No.:	Sub-No.:
3/1995	
Serial No.:	Limited distrib.:
3391-96	

<b>Main Office</b>	<b>Regional Office, Sørlandet</b>	<b>Regional Office, Østlandet</b>	<b>Regional Office, Vestlandet</b>	<b>Akvaplan-NIVA A/S</b>
P.O. Box 173, Kjelsås	Televeien 1	Rute 866	Thormøhlensgt 55	Søndre Tollbugate 3
N-0411 Oslo	N-4890 Grimstad	N-2312 Ottestad	N-5008 Bergen	N-9000 Tromsø
Norway	Norway	Norway	Norway	Norway
Phone (47) 22 18 51 00	Phone (47) 37 04 30 33	Phone (47) 62 57 64 00	Phone (47) 55 32 56 40	Phone (47) 77 68 52 80
Telefax (47) 22 18 52 00	Telefax (47) 37 04 45 13	Telefax (47) 62 57 66 53	Telefax (47) 55 32 88 33	Telefax (47) 77 68 05 09

<b>Report Title:</b> The CLIMEX Project: Whole catchment manipulation of CO <sub>2</sub> and Temperature	<b>Date:</b> Oct./95	<b>Printed:</b> NIVA 1996
	<b>Topic group:</b> Climate change	
<b>Author(s):</b> Nancy B. Dise (Editors) Alan Jenkins	<b>Geographical area:</b> East-Agder county, Norway	
	<b>Pages:</b> 130	<b>Edition:</b>

<b>Client(s):</b> European Commission Norwegian Ministry of Environment The Research Council of Norway National Environment Research Council (UK) Hydrogas Norge A/S	<b>Client ref.:</b>
---	---------------------

**Abstract:** This report gives a complete description of the CLIMEX project, including the experimental set-up and design, site description, pre-treatment data, and results from laboratory experiments. Separate chapters cover soils, hydrology, plant productivity, tree nutrient status, and ecophysiology. This report will also be published separately by the European Commission.

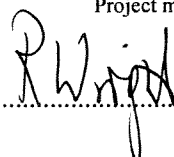
4 keywords, Norwegian

1. klimaendring
2. sur nedbør
3. økosystem
4. eksperiment

4 keywords, English

1. climate change
2. acid precipitation
3. ecosystem
4. experiment

Project manager

  
.....

Richard F. Wright  
.....

For the Administration

  
.....

Bjørn Olav Rosseland  
.....

ISBN-82-577-2921-3

## TABLE OF CONTENTS

	Page No.
<b>ACKNOWLEDGEMENTS</b>	i
<b>CHAPTER 1.</b> The CLIMEX Project	1
<b>CHAPTER 2.</b> Site Description And Experimental Design	9
<b>CHAPTER 3.</b> Soil Water Monitoring And Hydrological Response	27
<b>CHAPTER 4.</b> Input-Output Budgets	35
<b>CHAPTER 5.</b> Soil Chemistry And Decomposition Of Organic Matter	61
<b>CHAPTER 6.</b> Plant Productivity And Turnover	72
<b>CHAPTER 7.</b> Tree Nutrient Status And Growth	84
<b>CHAPTER 8.</b> Ecophysiological Responses Of Plants	96
<b>CHAPTER 9.</b> Soil Fauna	113
<b>CHAPTER 10.</b> Integration: Pre-Treatment Status Of CLIMEX Catchments	126

## *Acknowledgements*

---

The CLIMEX project is maintained with funding from the Commission of the European Communities (under contract No. EVSV-CT91-0047), Norwegian Ministry of the Environment, the Norwegian Research Council (NFR-NTNF) and Hydrogas Norge. Additional support for scientific research is provided by the Institute of Hydrology (UK) and the Dutch National Research Programme.

Financial support for operations at Risdalsheia during 1991-94 came in part from the Program for Deposition and Effects of Long-Range Transported Air Pollutants (TVLF) of the Norwegian Research Council, the Global Change Research Centre of Imperial College London (UK), and the Norwegian Institute for Water Research.

This work contributes to the GCTE (Global Change & Terrestrial Ecosystems) Core Project of the IGBP (International Geosphere-Biosphere Programme).

# Chapter 1

## *The CLIMEX Project*

---

A. Jenkins and N.B. Dise

Institute of Hydrology  
Wallingford, Oxon  
OX10 8BB  
United Kingdom

### 1. Introduction

CLIMEX (Climate change experiment) is an international, cooperative research project studying the response of entire catchments to increased CO<sub>2</sub> and temperature. The project involves five catchments at Risdalsheia, southernmost Norway, and employs multiple treatments and controls (Table 1.1). One catchment (KIM) is contained within a 1200 m<sup>2</sup> greenhouse in which atmospheric CO<sub>2</sub> is enriched to 560 ppmv and air temperature is increased to 3-5°C above ambient. As part of the RAIN project (Wright et al., 1988) KIM has also received clean rainfall since 1984. At a second catchment (EGIL), a temperature increase of 3-5°C is achieved by soil warming using electric cables placed on the soil surface. Three untreated reference catchments are also monitored.

**Table 1.1** Overview of the 5 catchments at Risdalsheia included in the CLIMEX project.

---

Catchment	Area (m <sup>2</sup> )	Enclosure	Rain quality	Climate treatment	Start of monitoring
KIM	690	roof	clean	CO <sub>2</sub> + air warming	June 1983
(Control)	170	roof	clean	none	June 1983
EGIL	320	roof	acid	soil warming	June 1983
(Control)	80	roof	acid	none	June 1983
ROLF	220	no roof	acid	none	June 1983
METTE	650	no roof	acid	none	June 1993
CECILIE	380	no roof	acid	none	June 1993

---

CLIMEX focuses on the *whole ecosystem* response to climate change, in particular plant-soil-water linkages and processes. Plant physiology, soil fauna, nutrient cycling, turnover of organic matter, soil and soil solution, hydrological flowpaths, and runoff water quality are investigated. The results allow quantification of the ecosystem impacts of future climate

change and provide rate and process data for the construction, calibration and validation of process-oriented models. Such models will in turn be used to predict the response of forests and freshwaters in Europe to future changes in atmospheric CO<sub>2</sub> and climate.

## 2. Objectives

The objectives of CLIMEX are, by enriching CO<sub>2</sub> and elevating temperature to boreal forest catchments:

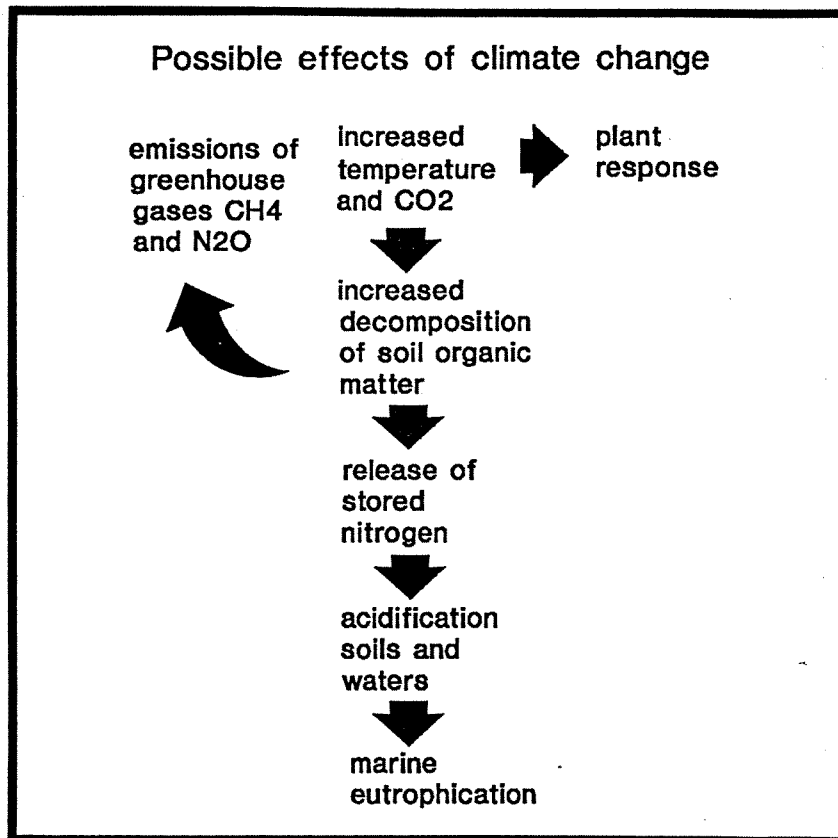
- to measure changes in plant CO<sub>2</sub> uptake, gas exchange and community phenology.
- to measure changes in forest growth and nutrient status.
- to measure changes in ground vegetation and nutrients.
- to determine changes in mineralization of soil organic matter.
- to determine changes in soil fauna and biologically-mediated processes.
- to measure the effects on runoff water quality and quantity.
- to develop and validate process-oriented models linking terrestrial and aquatic response.

CLIMEX provides information on the response to elevated CO<sub>2</sub> and temperature of primary production in terrestrial ecosystems. It also addresses the ways in which these terrestrial changes influence freshwater quality. Changes in forest primary production and phenology provide essential information for evaluating forestry practices in Europe under global change scenarios. Climate-induced changes in freshwater quality will have consequences for a broad range of socio-economic factors. This research is intended to provide direct information on the effects of future climate change to forest ecosystems in Europe and so has immediate relevance for environmental policies related to emission controls of greenhouse gases.

## 3. Background

Projected increases in atmospheric CO<sub>2</sub> and temperature can be expected to affect temperate and boreal forests ecosystems at many levels (Boer et al. 1990, Mooney et al. 1991). Predicting these effects is a considerable scientific challenge. At the individual plant level, increased CO<sub>2</sub> and temperature would be expected to increase growth and increase the C/N content of litter. Increased temperature, however, will also increase evapotranspiration which may increase periods of soil drying and *decrease* plant growth. Mineralization should also be increased by temperature increases, but only if the soils remain moist and if litter quality is not reduced by substantial increases in C/N ratios or by shifts in species composition. Mineralization in turn may release gases including the greenhouse gases CH<sub>4</sub> and N<sub>2</sub>O to the atmosphere (Van Breemen and Feijtel 1990), and nutrients such as nitrogen and phosphorus to soil solution, surface waters and the marine environment (Schindler et al. 1990). Soil and water acidification and eutrophication of freshwater and marine ecosystems are possible results (Figure 1.1).

Because of these linkages, the *ecosystem* response to changing climate (the relevant scale) may be exceedingly difficult to predict from simple greenhouse or laboratory experiments. CLIMEX seeks to quantify this ecosystem response to climate change. Other experimental approaches such as open-top chambers, free-air-circulation experiments (FACE), and soil heating cables provide experimental data on the effects of CO<sub>2</sub> or temperature alone, over a shorter time period or on only parts of the forest ecosystem.

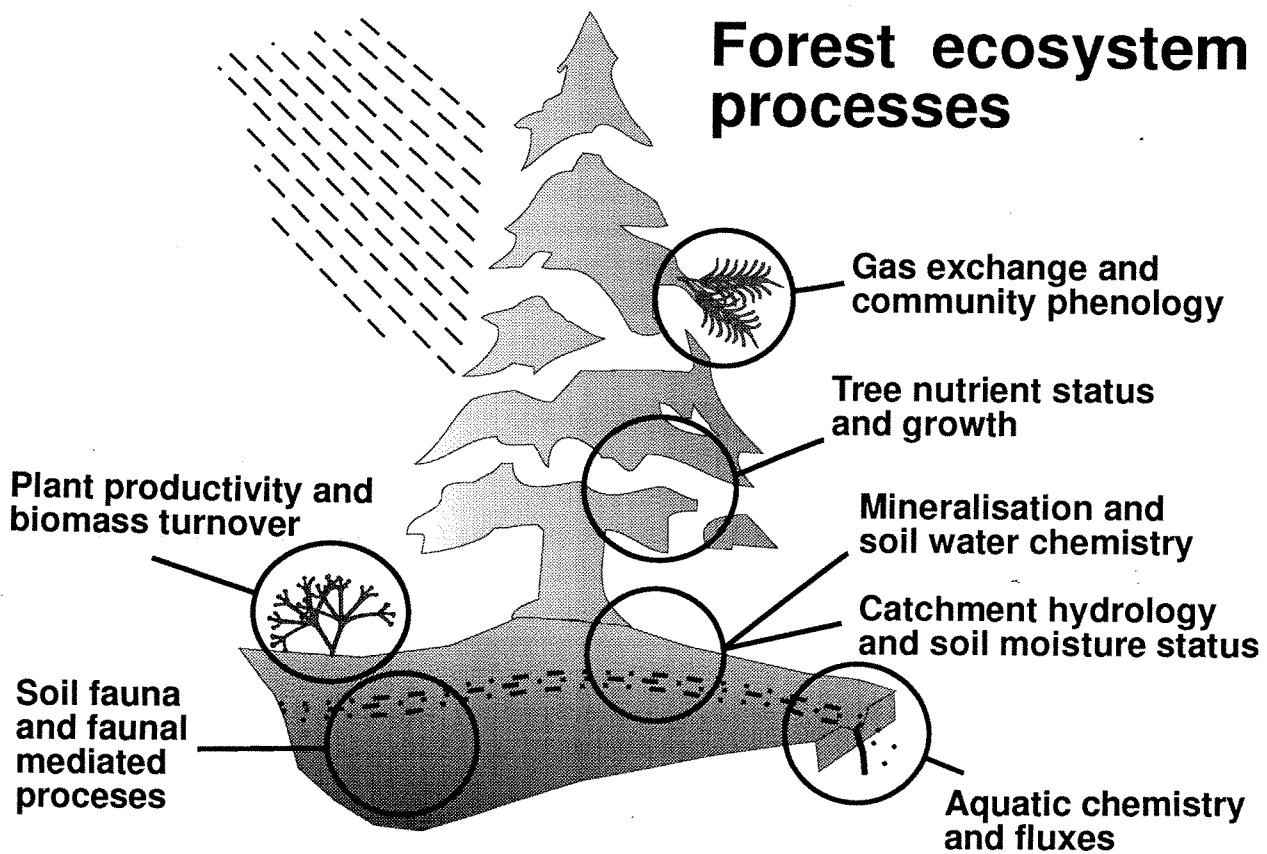


**Figure 1.1** Possible ecosystem responses to climate change.

Investigation of ecosystem-scale response requires ecosystem-scale experiments. Large-scale experiments with entire ecosystems offer a powerful scientific tool to investigate the effects of global change (Wright et al. 1988, Wright 1991). The short-term (up to one year) ecosystem response to a step change increase in temperature and atmospheric CO<sub>2</sub> is being studied as part of the first phase of CLIMEX. Different parts of the ecosystem will probably respond at different rates for as long as the treatment is continued. Key responses which require quantification are the rates at which the system responds, the potential for achieving a new "equilibrium" condition, and the feedback responses which might operate to limit the ecosystem response in the longer term.

CLIMEX offers a unique opportunity to link detailed studies of vegetation, soils and soil fauna with large-scale catchment measurements of hydrology and nutrient fluxes. This will be achieved in part by calculating and measuring the CO<sub>2</sub> fluxes from leaves, whole plants and soil in the ecosystem. CO<sub>2</sub> fluxes are an ideal intermediary between plant and ecosystem as hydrological changes are closely integrated with the growth and nutrient uptake processes of the individual plants and organisms in the soil, which in turn are linked to CO<sub>2</sub> availability.

The hypotheses under test in CLIMEX are divided into various ecosystem compartments overseen by different research specialists (Figure 1.2). It must be stressed, however, that these study areas are interrelated and this interaction is a major aspect of the experiment. Details of each study area and the pre-treatment status of the CLIMEX sites are discussed in following chapters and integrated in Chapter 10.



**Figure 1.2** Schematic of the forested catchment ecosystem showing major components and processes to be investigated in CLIMEX.

#### 4. Study Areas - Hypotheses

##### *Soil Hydrology (Chapter 3)*

Catchment runoff should decrease in response to increased evapotranspiration, although this may be counterbalanced by enhanced water use efficiency of plants exposed to high CO<sub>2</sub> (Chapter 6). The hydrological and hydrochemical response to storm events will change in response to changes in water uptake by the plants and changes in flow pathways as soils dry and crack.

##### *Input-Output Budgets (Chapter 4)*

In the absence of other factors, increased temperature should lead to increased mineralization of soil organic matter. This depends, however, on the hydrologic response of the catchment. Enhanced mineralization may cause increased leaching of nitrogen in the form of nitrate from the manipulated catchments. Leaching of nitrate, a strong acid anion, can cause acidification of soil and runoff as manifest by changes in pH and aluminium concentrations.



## *Primary Production and Soil Organic Matter Mineralization (Chapters 5 and 6)*

Increased temperature is expected to cause an increase in nutrient mineralization. This would increase plant production and turnover of leaves and roots, resulting in higher inputs of dead organic matter into the soil. Increased CO<sub>2</sub> should also lead to increased primary production and biomass turnover but the material produced will contain more refractory compounds, leading to *lower* decomposition rates. Rates of decomposition and mineralization would thus be initially enhanced by warmer temperatures, but would gradually be suppressed by the production of increasingly refractory plant material under high CO<sub>2</sub>. Over the time span of several years, overall nutrient losses are expected to increase compared to present-day values.

## *Forest Growth and Nutrient Status (Chapter 7)*

Elevated CO<sub>2</sub> might enhance photosynthesis and thus increase the C/N ratio in plant leaves. This will be associated with an increase in soluble carbohydrate (starch) formation. Plants may also respond by increased growth, possibly resulting in nutrient deficiencies, especially under conditions of acid deposition. Over a longer time period, high levels of soluble carbohydrates could stimulate production of nitrate reductase enzyme (NRA) and improve the growing conditions of the tree. Ultimately, C/N ratios may adjust back to pre-treatment levels.

## *Photosynthesis, Gas Exchange and Phenology (Chapter 8)*

Modelling studies suggest that soil nutrient status strongly influences plant gas exchange (Woodward and Smith 1994). The model predicts that photosynthesis of dominant surface-rooting shrubs will respond only slightly to CO<sub>2</sub> enrichment alone but will respond much more strongly to a combination of CO<sub>2</sub> enrichment and warming. Deeper-rooting trees, in contrast, are predicted to respond strongly to both CO<sub>2</sub> and warming alone and in combination. Soil decomposition rates should also increase with warming such that some ecosystems may turn from CO<sub>2</sub> sinks to CO<sub>2</sub> sources.

## *Soil Faunal Effects on Litter Decomposition (Chapter 9)*

An initial increase in soil faunal activity is anticipated if organic matter mineralization increases. This may be followed by a decrease in soil fauna as a result of the expected change in substrate quality (higher C:N and lignin:N ratios, higher polyphenol content). Although the quality of litter produced under raised CO<sub>2</sub> and temperature may decrease, the contribution of the soil fauna relative to that of microflora may become greater since changes in litter quality will primarily affect the microflora.

## *Process-Oriented Models*

The effects measured in CLIMEX will be integrated into process-oriented models which will initially draw upon existing models of hydrology (IDHM -- Calver 1988), hydrochemistry (MAGIC -- Cosby et al. 1985) and soil chemistry (CENTURY -- Parton et al. 1987; NIICCE -- Van Dam and Van Breemen 1994). The MAGIC model has already been used to successfully predict runoff in KIM and EGIL and the response of KIM to the clean rain treatment (Cosby et al. in prep). Similarly, IHDM has been applied at EGIL to assess its suitability in these catchments.

An essential development of these models is incorporation of the relevant feedbacks which might enhance or mitigate the impact of climate change on the catchment. At the end of CLIMEX we expect to have a catchment-scale integrated model to evaluate the effects of future changes in CO<sub>2</sub> and temperature on boreal forest ecosystems. We shall use the integrated data collected in CLIMEX to validate the model. The longer-term response, especially the capacity of the ecosystem for continual changes in rates and processes, must be incorporated into catchment models to provide effective tools for scenario assessment across Europe.

## **5. Project Organization and Management**

The CLIMEX project brings together expertise from research groups in several European countries. Such a joint effort is required to carry out an experiment of this complexity and scale. The multidisciplinary nature demanded by the project objectives is reflected in the diverse scientific disciplines involved, encompassing geochemistry, meteorology, hydrology, plant physiology, soil science, and systems analysis.

Researchers at the Institute of Hydrology (IH), UK, coordinate and manage the scientific programme within CLIMEX and are responsible for catchment hydrology and integrated modelling. The Norwegian Institute for Water Research (NIVA), Norway, act as site manager and conduct daily operations including maintenance, sampling and chemical analyses. NIVA are also responsible for input-output budgets of water and chemicals and aquatic effects. The University of Sheffield (US), are responsible for photosynthesis and plant phenology measurements. Three separate research groups at Wageningen Agricultural University (AUW), and the Research Institute for Agrobiological Sciences (RIAS), the Netherlands, are responsible for (1) soil, soil solution and mineralization studies (2) primary production and plant biomass turnover, and (3) soil faunal studies. The University of Bayreuth (UB), Germany, are responsible for tree growth and nutrient cycling.

## **6. CLIMEX and Global Change Research**

The CLIMEX experiment is the first such large-scale CO<sub>2</sub> enrichment and climate change experiment in the world, and CLIMEX is constructed in a vegetation type (boreal forest) which is predicted to be sensitive to climatic change. Within the International Geosphere-Biosphere Programme (IGBP), the core project on Global Change and Terrestrial Ecosystems (GCTE) has clearly highlighted the need for experiments such as CLIMEX which investigate ecosystem-scale interactions. CLIMEX has been accepted as a core research project within GCTE. Data from CO<sub>2</sub>-only experiments and temperature-only experiments can be combined with the whole-catchment results from CLIMEX to extrapolate the results to a variety of systems. Additionally, the process-oriented models developed as part of CLIMEX will provide a tool by which the results can be applied to other environments.

Whole-ecosystem manipulation experiments provide perhaps the only means by which the validity of small-scale experiments can be assessed. Schindler (1989), for example, points out that the results from small-scale experiments are sometimes corroborated by whole-lake experiments, but in other cases the results, although statistically significant, are in fact simply an artifact of the experimental design. CLIMEX can be used to evaluate results from such small-scale experiments.

CLIMEX continues to attract researchers from outside of the core project group to study other aspects of ecosystem function and response, for example; mosses and bryophytes (University of Tromso, Norway), sulphur isotopes in precipitation and runoff (University of Stockholm, Sweden), fish toxicity studies (NIVA, Norway) and techniques for regionalization of models for 'scaling up' ecosystem response (University of Virginia, USA). Such participation is encouraged, not only to provide useful input to the project but, more importantly, to reinforce the focus a large-scale manipulation experiment can provide.

## 7. Project Status

CLIMEX began in December 1992 with the installation of measurement equipment. One year's background data (pre-treatment) was collected during the period April 1993 through March 1994. Treatment began in April 1994. The duration of CLIMEX is driven by available funding, but it is expected that several years will be necessary to record the full response of the vegetation, soils and waters to the new climatic conditions. This report presents the results of the first (pre-treatment) year.

## 8. References

- Boer, M.M., E.A. Koster, and H. Lundberg. 1990. Greenhouse impact in Fennoscandia -- preliminary findings of a European workshop on the effects of climatic change. *Ambio* 19: 2-10.
- Calver, A. 1988. Calibration, sensitivity and validation of a physically-based rainfall-runoff model. *J. Hydrology* 103: 103-115.
- Cosby, B.J., Hornberger, G.M., Galloway, J.N. and Wright, R.F. 1985. Modelling the effects of acid deposition: assessment of a lumped-parameter model of soil water and streamwater chemistry. *Water Resources Research* 21: 51-63.
- Cosby, B.J., Wright, R.F. and Gjessing, E. An acidification model (MAGIC) with organic acids evaluated using whole-catchment manipulations in Norway. *Journal of Hydrology*, in prep.
- Mooney, H.A., B.G. Drake, R.J. Luxmore, W.C. Oechel, and L. Pitelka. 1991. Predicting responses to elevated CO<sub>2</sub> concentrations. *Bioscience* 41: 96-104.
- Parton, W.J., Schimel, D.S., Cole, C.V., and Ojima, D.S. 1987. Analysis of factors controlling soil organic matter levels in Great Plains grasslands. *Soil Sci. Soc. Am. J.* 51: 1173-1179
- Schindler, D.W. 1989. Experimental studies of chemical stressors on whole lake ecosystems. *Verh. Internat. Verein. Limnol* 23; 11 - 41.
- Schindler, D.W., K.G. Beaty, E.J. Fee, D.R. Cruikshank, E.R. DeBruyn, D.L. Findlay, G.A. Lindsey, J. A. Shearer, M.P. Stainton, and M.A. Turner. 1990. Effects of climatic warming on lakes of the central boreal forest. *Science* 250: 967-970.

- Van Breemen, N. and T.C.J. Feijtel. 1990. Soil processes and properties involved in the production of greenhouse gases, with special references to soil taxonomic systems. p.195-223, In, A.F. Bouman (ed.) Soil and the Greenhouse Effect. (Wiley, Chichester, UK).
- Van Dam, D., and Van Breemen, N. 1994. NIICCE: A model for cycling of Nitrogen and Carbon isotopes in coniferous forest ecosystems. Modelling of Geo-Biosphere Processes, in press.
- Woodward, F.I. and Smith, T.M. 1994. Predictions and measurements of the maximum photosynthetic rate,  $A_{max}$ , at the global scale. In, E.D. Schulze and M.M. Caldwell. (eds) Ecophysiology of Photosynthesis. Ecological Studies 100 (Springer - Verlag, Heidelberg).
- Wright, R.F. 1991. Acidification: whole-catchment manipulations. p. 167-179, In Mooney, H.A. et al. (eds.) Ecosystem Experiments SCOPE 45 (Wiley, Chichester, UK).
- Wright, R.F., E. Lotse, and A. Semb. 1988. Reversibility of acidification shown by whole-catchment experiments. Nature 334: 670-675.

# Chapter 2

## *Site Description and Experimental Design*

---

Richard F. Wright

Norwegian Institute for Water Research  
Box 173 Kjelsås  
0411 Oslo, Norway

### **1. Introduction**

The CLIMEX project is located at Risdalsheia, southernmost Norway. Risdalsheia is situated at 58°23' N latitude, 8°19'E longitude in the municipality of Grimstad, Aust-Agder county, about 20 km inland from the North Sea (Figure 2.1). The site is 300 m above sea level, on the upland plateau. The site is typical of large areas of upland southern Norway, with a maritime climate, granite bedrock, glaciated terrain with thin and patchy podsollic and peaty soils, numerous lakes, ponds and peaty areas, and sparse forests of pine and birch above heather and blueberry ground vegetation.

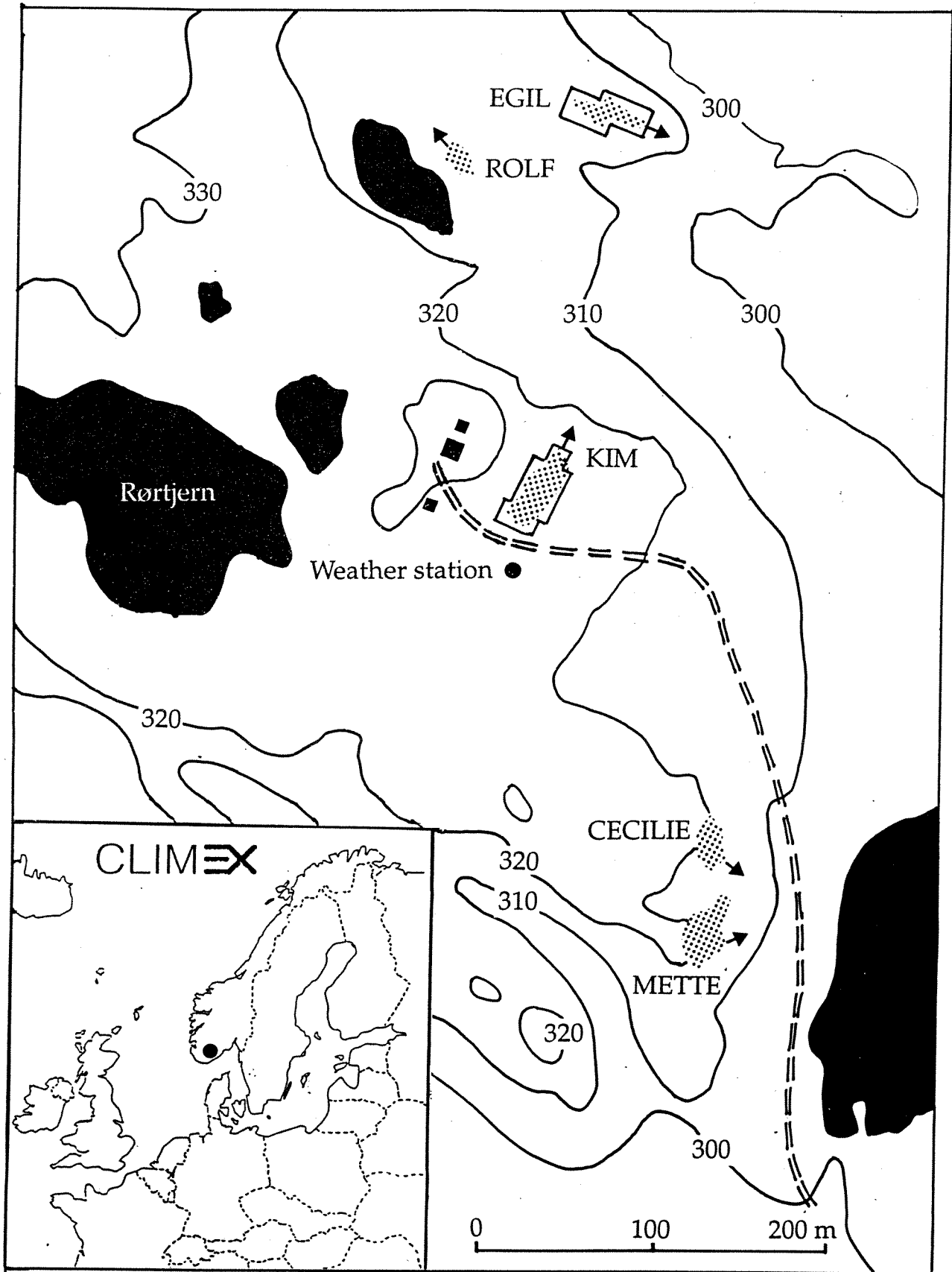
Risdalsheia was established as a research site in 1982 as part of the RAIN project (Reversing Acidification In Norway) (Wright et al. 1988, 1993). Among criteria used in the original selection were presence of numerous small (100-1000 m<sup>2</sup>) hydrologically well-defined catchments, undisturbed vegetation and soils, ready access by road, availability of electricity, and possibility of long-term lease of the site from the landowner.

The existing 3 catchments (KIM - clean rain, roof; EGIL - acid rain, roof; ROLF - acid rain, no roof) at Risdalsheia operated during the period 1983-1993 by the RAIN project have been carried over to the CLIMEX project. In addition 2 new untreated reference catchments have been added (METTE and CECILIE) (Chapter 1).

### **2. Site description**

#### *Bedrock, Soils and Vegetation*

Risdalsheia is on the Herefoss granite, a true granite with biotite the major dark mineral. Cover of organic-rich, podsollic soil is thin (average depth 5-11 cm) and patchy with about 30-50% of the area exposed bedrock (Lotse and Otabbong 1985) (Figs. 2.2-2.6). Extensive data on the chemical composition of the soil is available from annual surveys conducted from 1983 through 1990 (except 1989) as part of the RAIN project (Table 2.1) (Wright et al. 1993). Cores were taken at 2 m intervals along fixed transects across each catchment and analyses included exchangeable cations, carbon, nitrogen and sulphur contents, bulk density, and water-soluble and adsorbed sulphur. Procedures are described by Lotse and Otabbong (1985), and the original data through 1986 are listed in Lotse and Otabbong (1985) and Lotse (1989). These surveys do not reveal any long-term changes due to the clean-rain treatment.



**Figure 2.1** Location of the experimental catchments at Risdalsheia (RAIN project). Contour lines are given in meters.

**Table 2.1** Characteristics of soils at the Risdalsheia catchments. Values are mass-weighted averages of all samples (35-110 samples per catchment) collected over all years (1983-90).

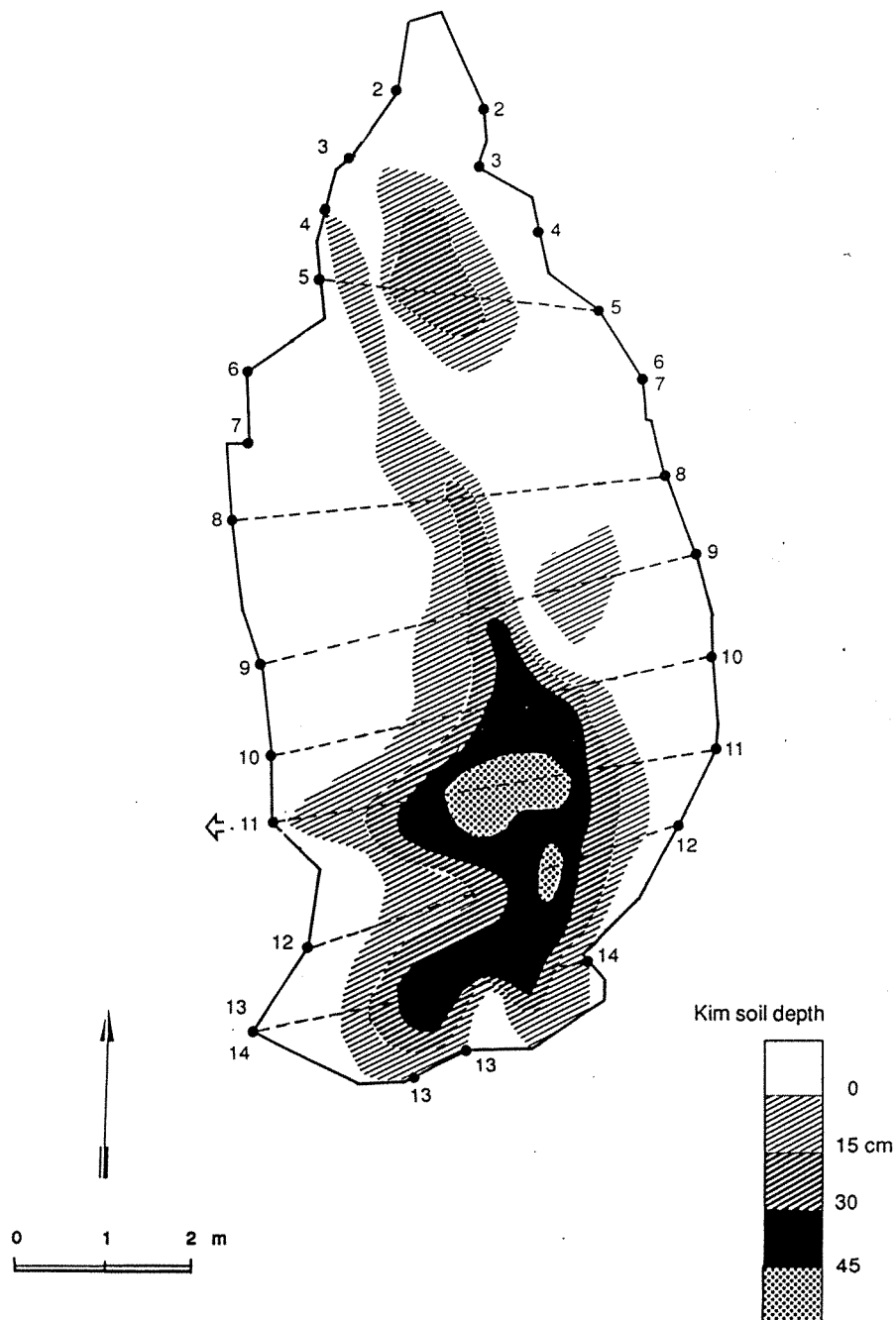
Parameter	Units	KIM (roof, clean)	EGIL (roof, acid)	ROLF (no roof, acid)
Area	m <sup>2</sup>	860	395	220
Soil depth	cm	11	5	10
Soil volume	m <sup>3</sup>	90	21.7	20.9
Bulk density	kg/m <sup>3</sup>	0.73	0.53	0.66
Soil mass	ton	56.1	9.6	8.7
pH (KCl)		4.36	4.28	4.27
Loss on ignition	%	24.2	26.2	25.2
C	%	13.8	13.9	12.7
N	%	0.71	0.65	0.55
S	%	0.08	0.09	0.07
<i>Exchangeable cations</i>				
<i>(KCl)</i>				
CEC	meq/100g	9.7	9.7	8.5
H <sup>+</sup>	meq/100g	1.4	1.3	1.3
Al	meq/100g	5.7	6	4.6
Ca	meq/100g	1	0.8	1
Mg	meq/100g	0.6	0.4	0.6
Na	meq/100g	0.1	0.1	0.1
K	meq/100g	0.2	0.2	0.2
NH <sub>4</sub>	meq/100g	0.7	0.8	0.6
Base Saturation	%	19.6	15.5	22.4
SO <sub>4</sub> water-sol	meq/kg	1.1	1.2	1.3
SO <sub>4</sub> ads.	meq/kg	0.6	0.6	0.8

Vegetation is mainly a sparse cover of pine (*Pinus sylvestris* L.) and birch (*Betula pubescens* L.) with heather (*Calluna vulgaris* L.) and blueberry (*Vaccinium myrtillus* L.) the dominant ground species. The area is classed as unproductive forest. There are no tree stumps or other evidence of disturbance in the catchments.

Vegetation of KIM, EGIL and ROLF was mapped in the summer of 1991 (Figs. 2.7-2.9). The distribution of vegetation clearly follows soil depth (Figs. 2.2-2.4). Both ROLF and EGIL are dominated by *Calluna vulgaris*, a drought-resistant species which can survive in thin soils less than 15 cm deep (Wohlfeil and Müller, 1992). *Vaccinium myrtillus* occurs in competition with *Calluna* in all parts that supply enough soil moisture. The appearance of *Erika tetralix* with the *Calluna* and other species in EGIL indicates areas with deeper soils (Figure 2.3) and higher soil moisture, including some stagnant water. Species diversity is

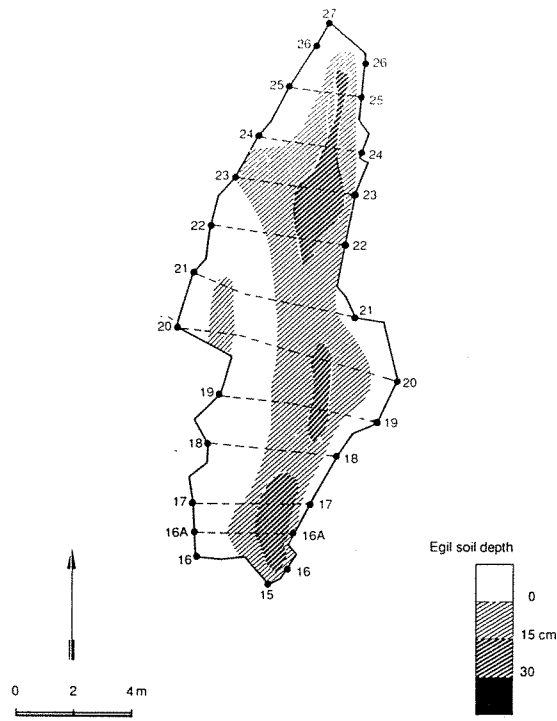
highest in KIM, which contains large areas of *Vaccinium myrtillus* beneath shrubs and trees in the catchment centre (Figure 2.7). Here soils are deeper than 20 cm and moisture is comparatively high.

The vegetation pattern in KIM is not exceptionally different from the untreated uncovered sites, and there is no indication (from photographs and observation) that the RAIN treatments have significantly affected species composition or diversity (Wohlfeil and Müller, 1992). However, lichens and mosses in KIM appear healthier than in the acid rain catchments, and there are nearly twice as many lichen species in KIM (21) than in EGIL (11) (Wohlfeil and Müller, 1992), which may partly be a result of the reduced sulphate deposition.

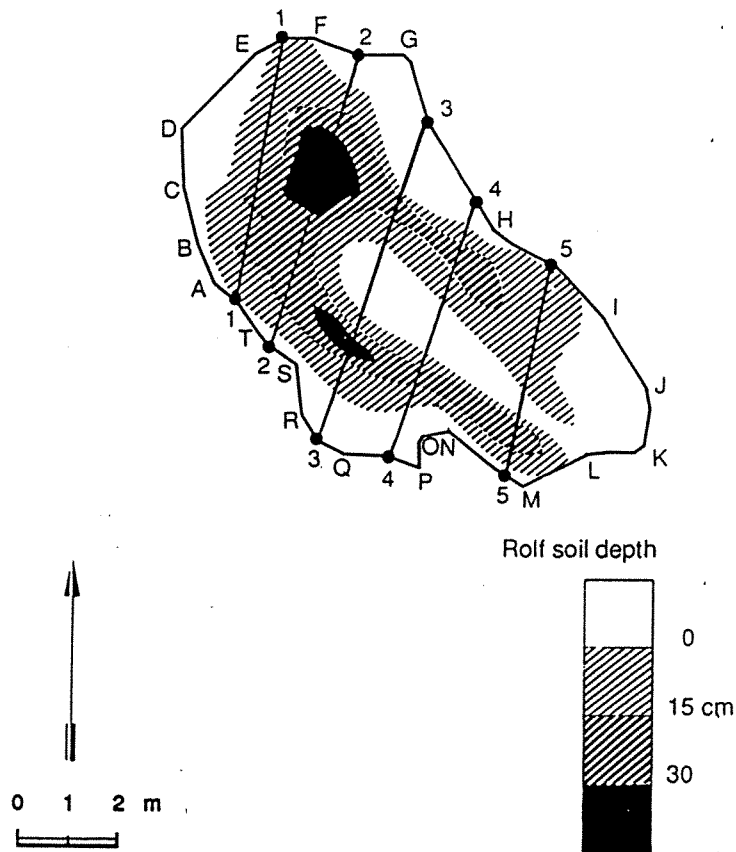


**Figure 2.2** Soil depth map of KIM catchment (from Lotse and Otabbong 1985).

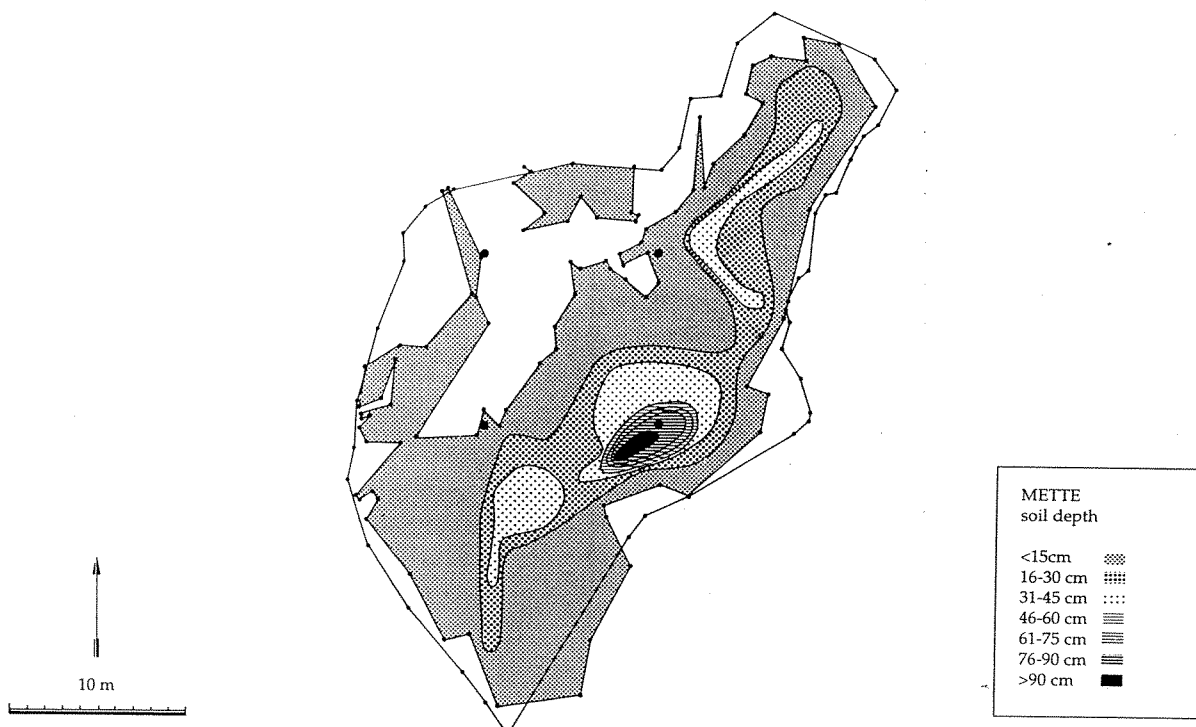




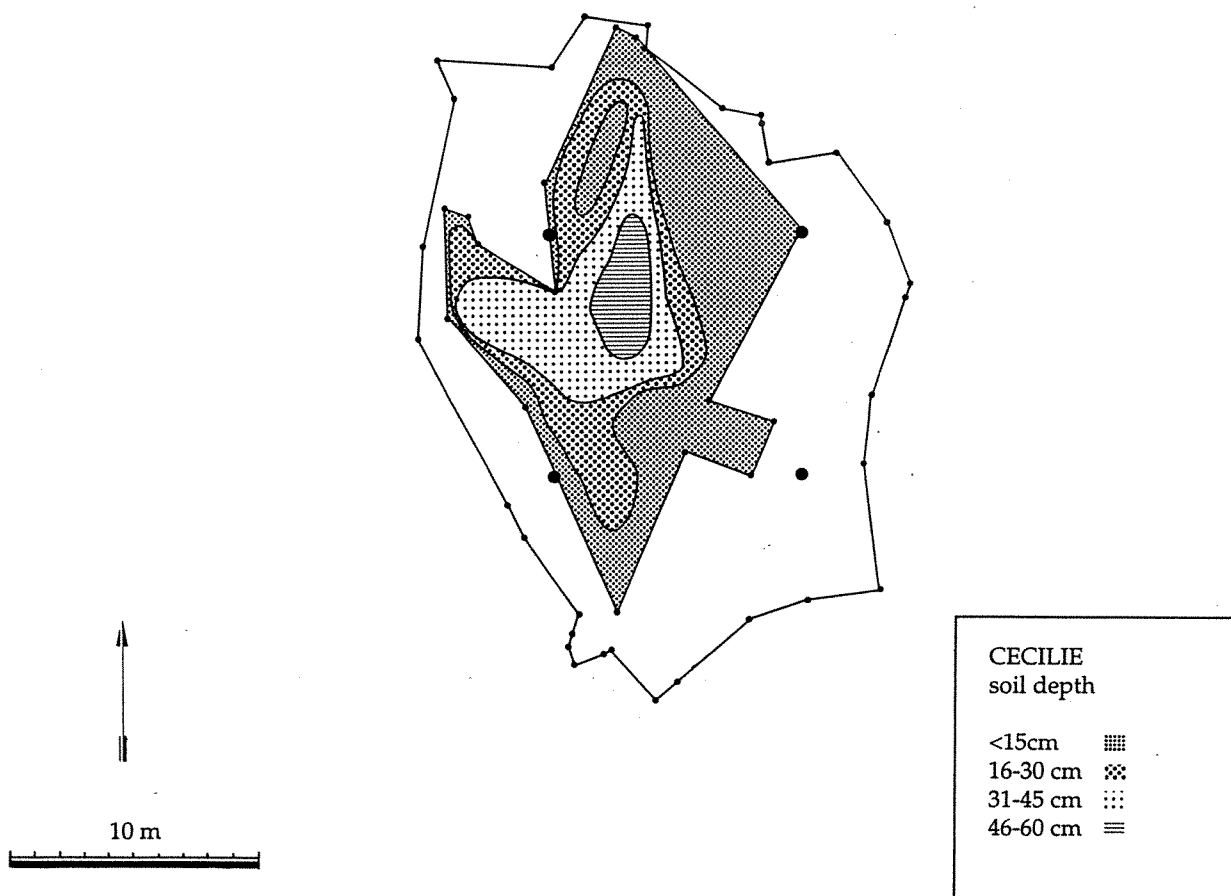
**Figure 2.3** Soil depth map of EGIL catchment (from Lotse and Otabbong 1985).



**Figure 2.4** Soil depth map of ROLF catchment (from Wright 1987).



**Figure 2.5** Soil depth map of METTE catchment.



**Figure 2.6** Soil depth map of CECILIE catchment.

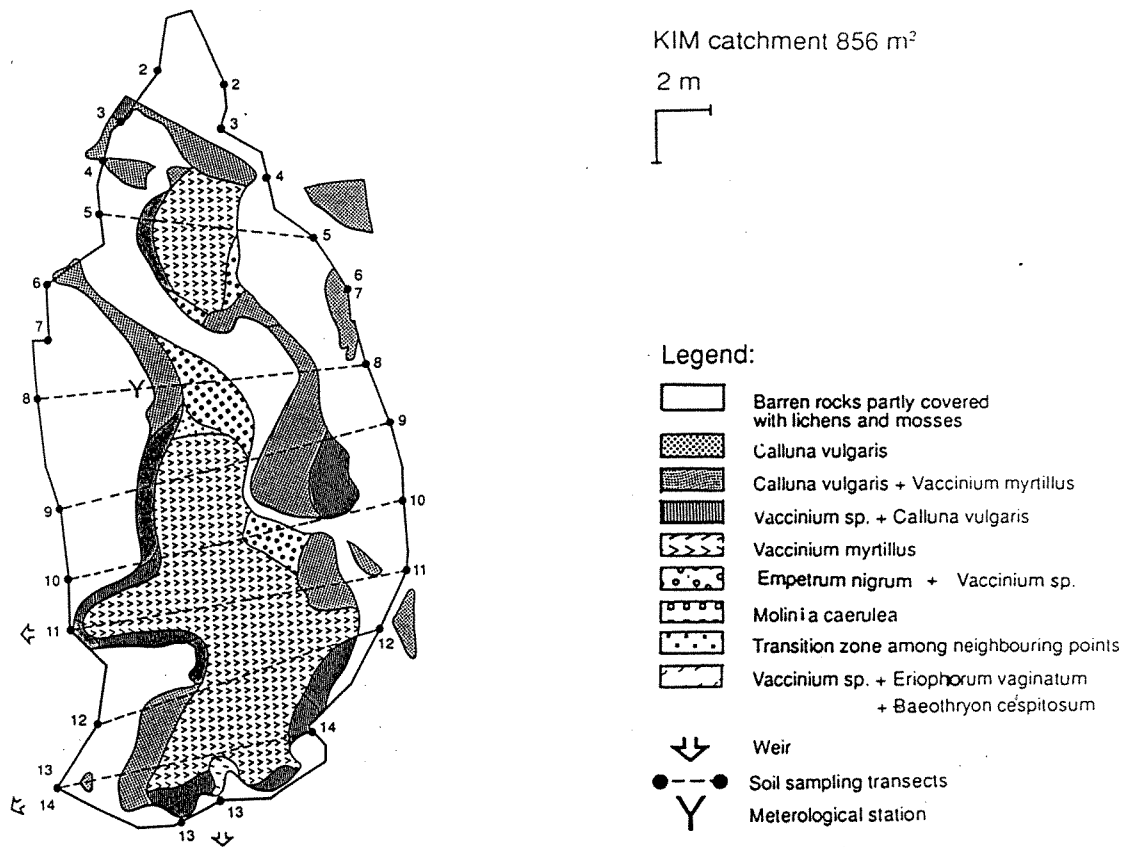


Figure 2.7 Vegetation map of KIM catchment (from Wohlfeil and Müller 1992).

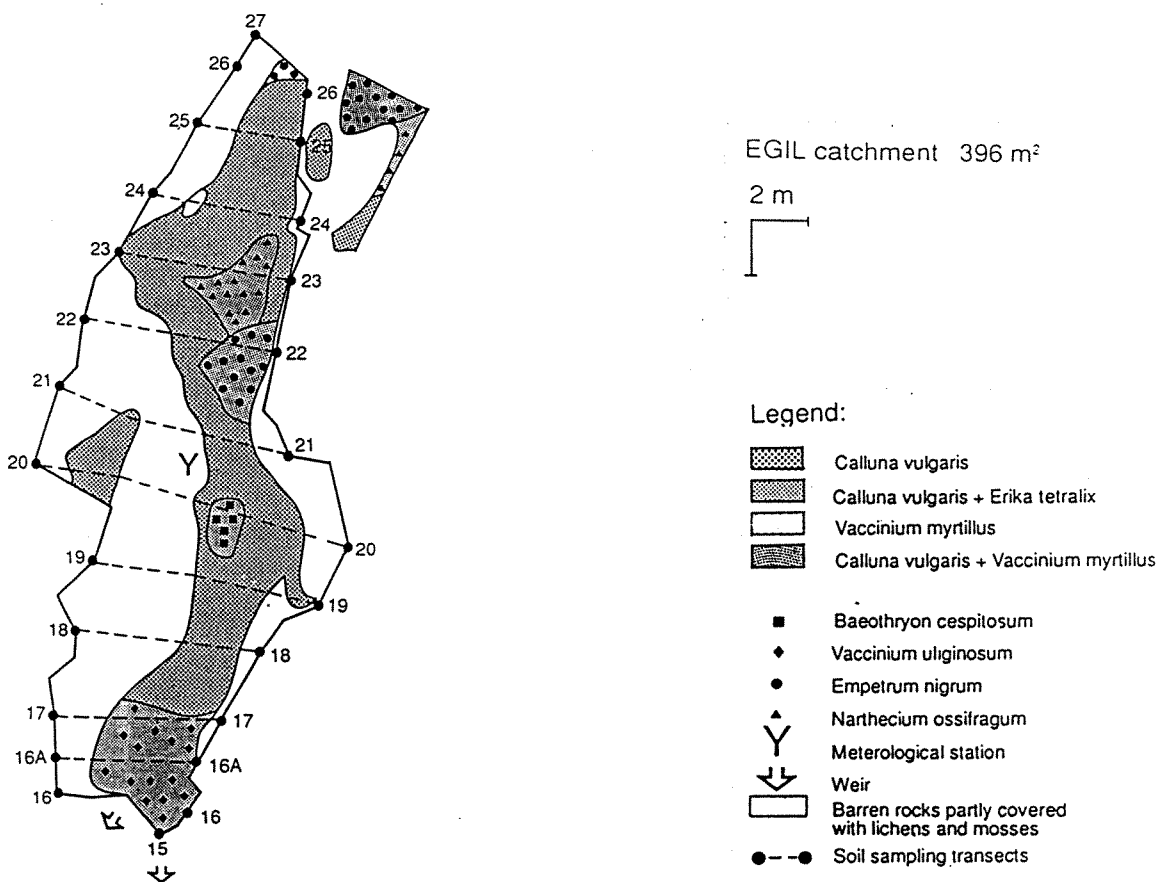
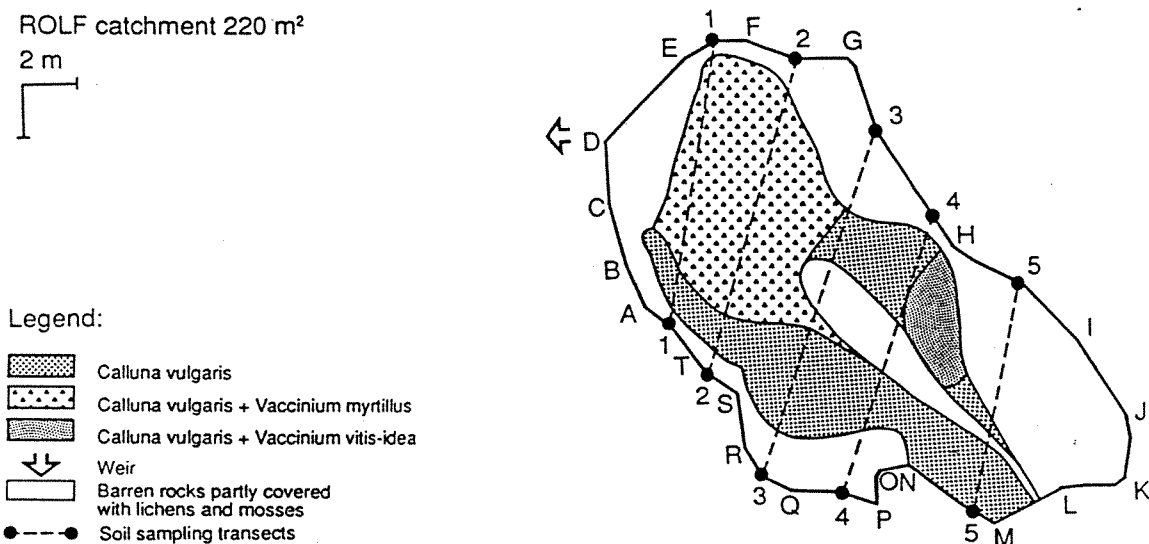


Figure 2.8 Vegetation map of EGIL catchment (from Wohlfeil and Müller 1992).



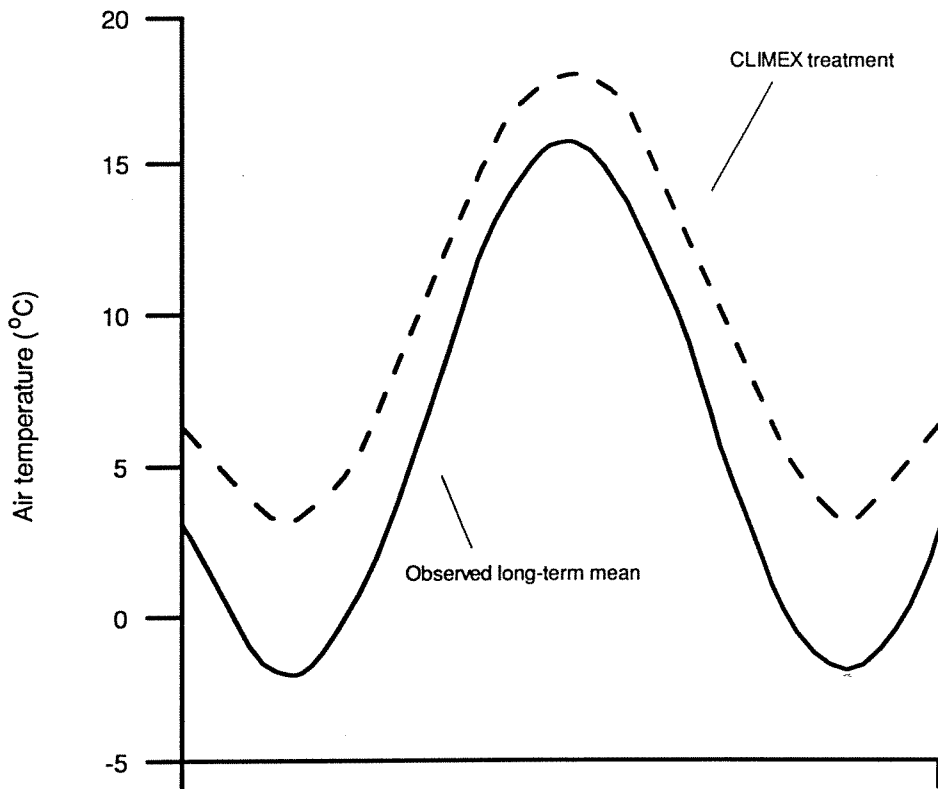
**Figure 2.9** Vegetation map of ROLF catchment (from Wohlfeil and Müller 1992).

### *Deposition, Climatic and Hydrologic Characteristics*

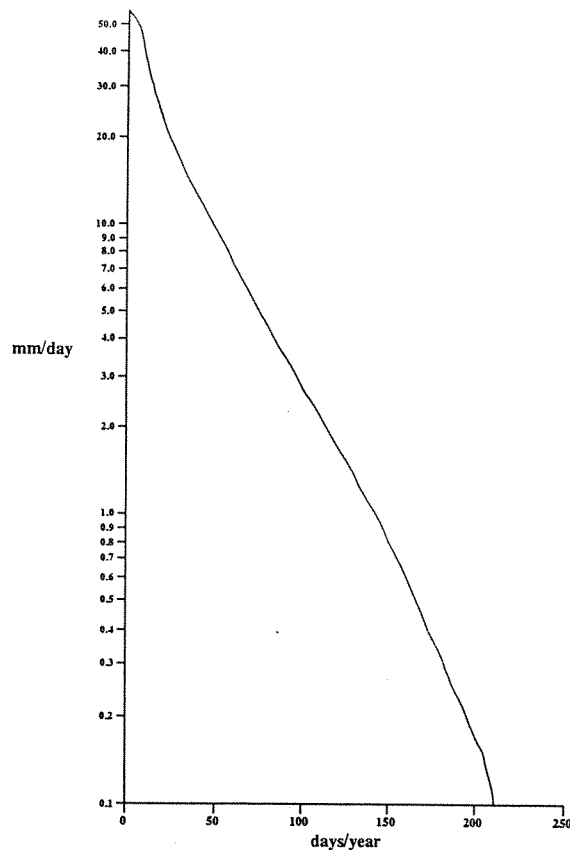
Extensive data from nearby stations operated by the Norwegian Meteorological Institute and compiled as national climate maps provide the best overview of climatic conditions at Risdalsheia (Aune, 1993). These are for the 30-year standard period 1961-1990. The mean annual temperature at Risdalsheia is about 5°C with a minimum mean of about -3°C in January and a maximum mean of about +16°C in July (Figure 2.10). The growing season (defined as daily mean temperature above +5°C) begins 15 April - 1 May and ends 15 October - 1 November.

Risdalsheia receives about 1400 mm precipitation annually, distributed unevenly with relatively dry spring and summer months and relatively wet autumn and winter months (Figure 2.10). Snow cover of 50-75 cm stays about 50-75 days per year. Precipitation of >0.1mm is recorded about 200-220 days per year and the maximum precipitation in a 24 hour period can reach about 100 mm (Figure 2.11). Wind speed in this area is typically in the range 3-11 m s<sup>-1</sup> with the dominant direction N to NE in January, NE to E in April, W to SW in July and W in October.

Data collected at the site since 1984 during the RAIN project give an 8-year mean precipitation of 1455 mm and runoff of 1255 mm (Wright et al. 1993). Risdalsheia receives high levels of acid deposition. Mean values of total deposition (wet and dry) for the 8-year period 1984-92 are 113 meq m<sup>-2</sup> yr<sup>-1</sup> sulphur, 132 meq m<sup>-2</sup> yr<sup>-1</sup> nitrogen (59 as NH<sub>4</sub><sup>+</sup> and 73 as NO<sub>3</sub><sup>-</sup>), and 106 meq m<sup>-2</sup> yr<sup>-1</sup> H<sup>+</sup> (Wright et al. 1993). Mean input and output fluxes of all major cations and anions over 8 years (1984-1992) are in Chapter 4.



**Figure 2.10** Mean monthly temperature and precipitation in the Risdalsheia area for the 30-year period 1961-90 (from maps in Aune 1993), plus CLIMEX temperature additions.



**Figure 2.11** Precipitation frequency in the Risdalsheia area for the 30-year period 1961-90 (from maps in Aune 1993).

### 3. Experimental design

#### *RAIN Project*

CLIMEX has inherited the experimental design established at Risdalsheia by the RAIN project. CLIMEX augments the RAIN treatments with additional manipulations at the same catchments. Three small catchments were selected in 1982 for the RAIN experiment. At KIM catchment incoming acid rain is excluded by means of a roof covering the entire catchment above the forest canopy. Precipitation is collected from the roof by gutters, led to storage tanks of 15 m<sup>3</sup> capacity, pumped through a filter and mixed-bed ion-exchange system, augmented by seasalts at natural levels for the area (1:8000 during the summer and 1:5000 during the winter), and reintroduced beneath the roof by a series of sprinklers mounted at about 4 m height (Figure 2.12). Maximum sprinkling rate is 2 mm hr<sup>-1</sup>. The entire system operates automatically such that the cleaned precipitation is applied within several hours of each event (Wright et al. 1993).

EGIL catchment is also covered by a roof and subjected to the same procedure except that the incoming precipitation is not filtered or treated by ion-exchange. Thus the ambient (acid) precipitation is simply recycled beneath the roof. The third catchment ROLF is an untreated reference catchment.

The roofs and sprinkling systems were constructed during the winter of 1983-84 with the transparent roof panels installed in May and early June 1984. Treatment started 14 June 1984 and has continued without major interruption since, for a total of 10 years. During the construction phase and subsequently during the 10-year RAIN project period, extreme care was taken to avoid disturbance of the vegetation and soils within the catchments.

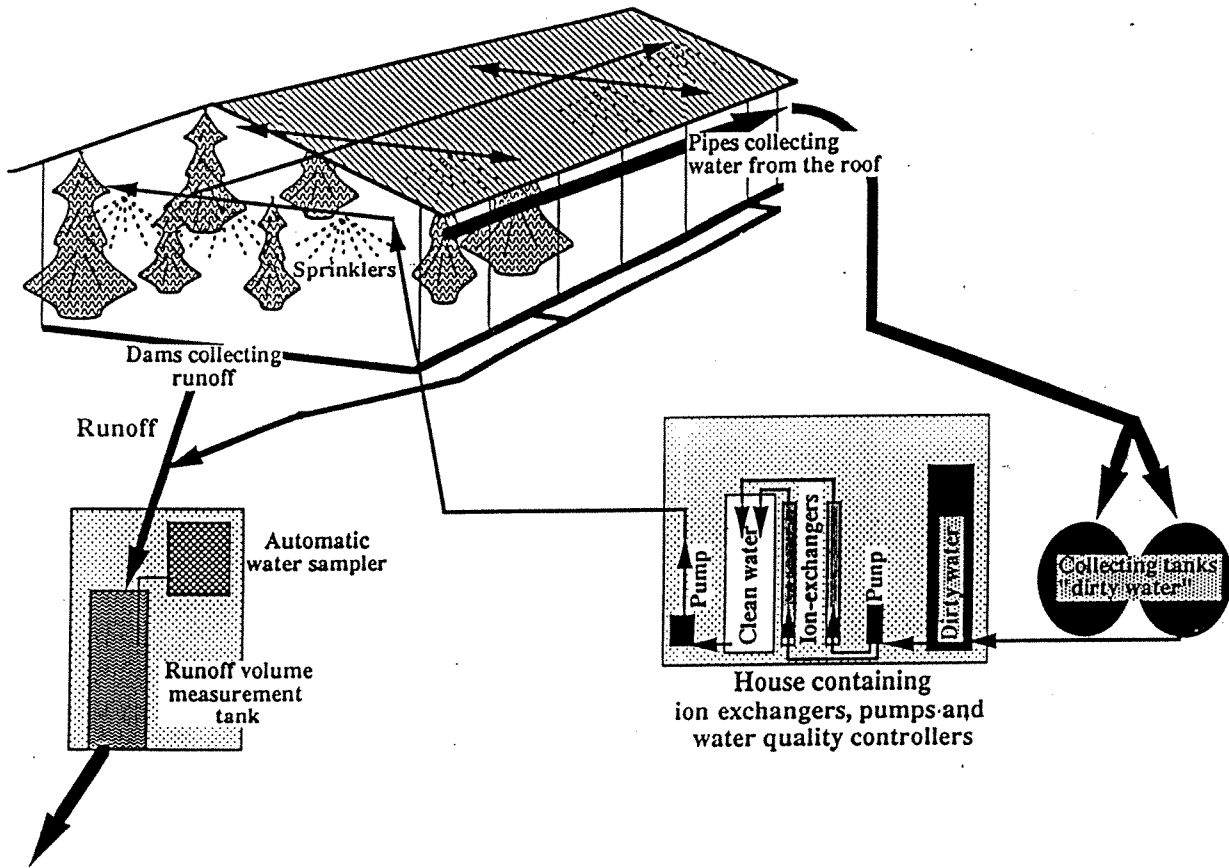
The major effect of the roof in both KIM and EGIL appears to be an approximately 50% reduction in photosynthetically active radiation (Figure 2.13). Effects which may be due to reduced light availability under the roof are discussed in the separate chapters and summarized in Chapter 10. Air temperatures under the roof are similar to the open except in winter, when they are slightly warmer (Figure 2.14). This is probably due to a decrease in net radiative loss through the roof and walls. The roof also reduces air movement under KIM and EGIL.

The sprinkling system also alters environmental conditions. Unlike the outside, both sprinkling intensity and raindrop size is constant under the roof. Additionally, small amounts of water are added under the roof if there is an extended summer drought (> ca 3 week's duration) to avoid potential wilting of vegetation.

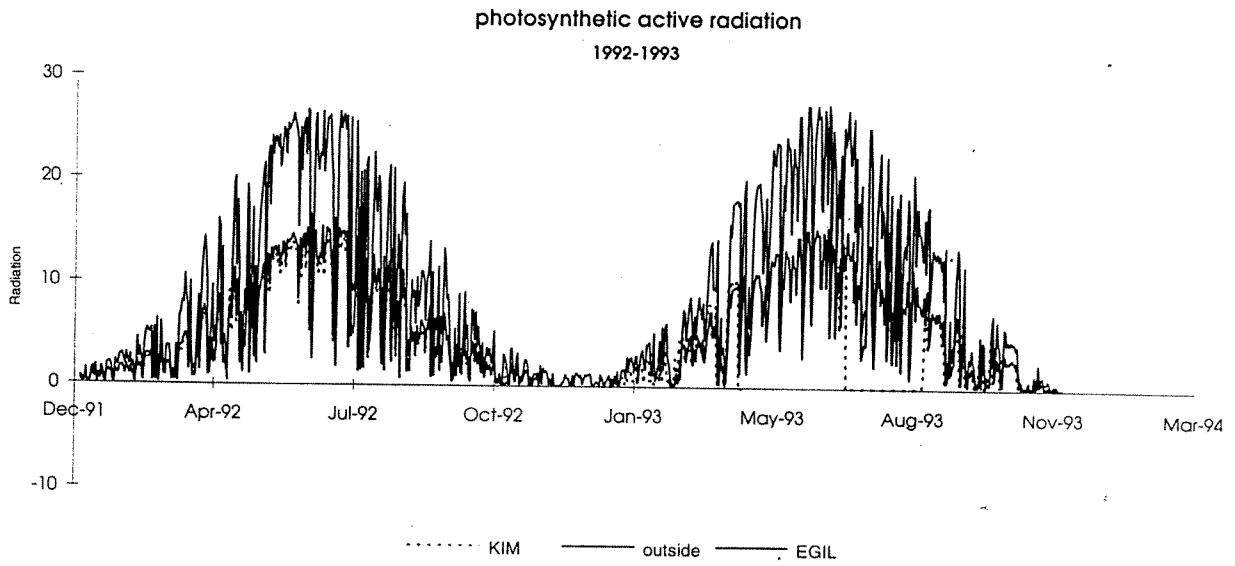
During the winters the sprinkling systems are shut down. At KIM catchment "clean" snow was made artificially using commercial snow making equipment. Water from the nearby lake was ion-exchanged and seasalts readded. This ceased in the winter of 1993-94 when the catchment was fitted with transparent air-tight walls as part of the CLIMEX experiment. Beginning with this winter and continuing through CLIMEX there is no snow cover in KIM in winter. At EGIL catchment, for the first year (1984-85) sulphuric acid and ammonium nitrate were added to make "acid" snow. In subsequent years, naturally acid snow outside the catchment was collected and redistributed under the roof using a snowblower. This will continue through CLIMEX.

The experiment at Risdalsheia takes the paired-catchment approach. Data from the pre-treatment period give a measure of the similarity between catchments. For the treatment period, comparison of ROLF catchment (acid, no roof) with EGIL (acid, roof) gives a measure of the roof effect, while comparison of EGIL with KIM (clean, roof) gives a measure

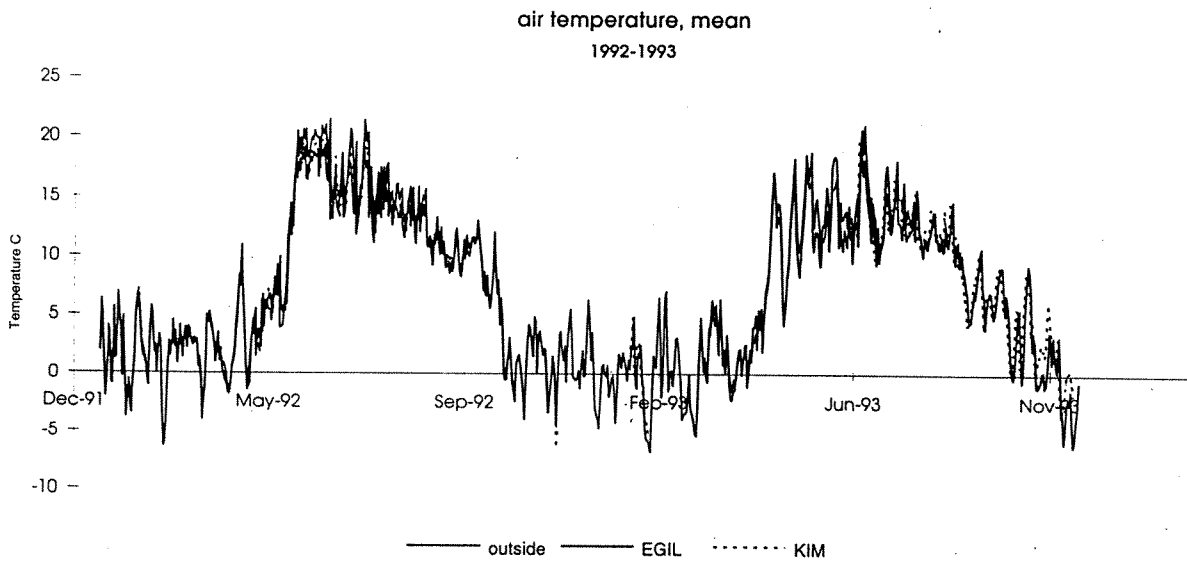
of the effect of changed deposition. As is the case with all paired-catchment experiments, the lack of replication precludes the use of conventional statistics to compare treatments. The statistical method of Randomised Intervention Analysis (Carpenter et al., 1989) developed for such experiments, may be used for treatment comparisons.



**Figure 2.12** Schematic diagram of the experimental setup at the roofed catchments at Risdalsheia. At the "clean" KIM catchment incoming precipitation is collected by means of a roof and gutter system, pumped through a filter and ion-exchange system, sea salts are added, and the clean rain is applied beneath the roof by means of a sprinkler system. The "acid" EGIL catchment has identical equipment except that the incoming precipitation is not ion-exchanged but is merely reapplied beneath the roof (from Wright et al. 1993).



**Figure 2.13** Comparison of photosynthetically active radiation under and outside the KIM roof.



**Figure 2.14** Comparison of air temperature under and outside the KIM roof.

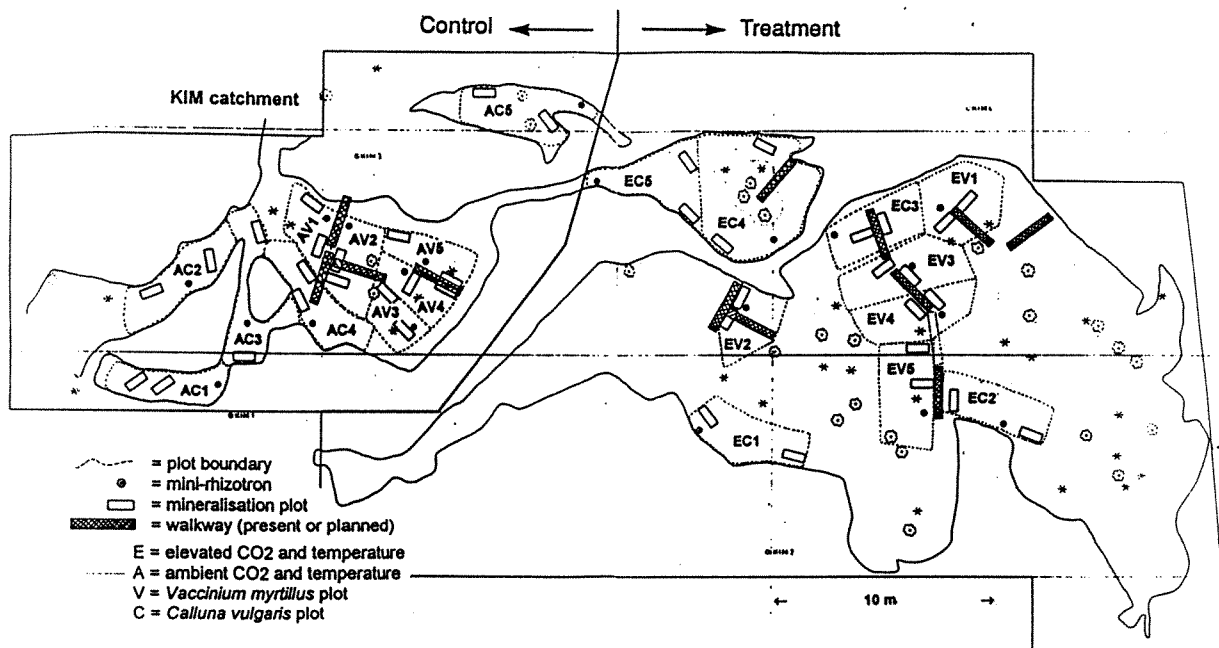


## CLIMEX Treatments

### KIM catchment: CO<sub>2</sub> and air warming

At KIM catchment (roof, clean rain) the air temperature and CO<sub>2</sub> concentration are increased. The existing structure was fitted with transparent air-tight walls in November 1993, and equipment for dosing CO<sub>2</sub> and heating the air were installed (Plate 2.1). A new transparent wall was installed across the uppermost part of the catchment such that the upper 20% of the catchment area will continue with the clean rain treatment only and will not receive higher CO<sub>2</sub> and temperature (Figure 2.15). This upper 20% serves as control area for plant and soil studies which are conducted on small plots of about 4-5 m<sup>2</sup>.

Carbon dioxide is added to the air at 6 points inside the treatment section (Plate 2.2). The target is 560 ppmv for all times when the temperature is above 4°C and below 42°C. Associated with each dosing point is an intake at which air is pumped continuously and CO<sub>2</sub> concentration measured. The targets are averages for 6 dosing and measurement points. Measurements are made by a central infra-red analyser located in the control hut just outside the enclosure. Maximum dosing rate is 55 kg hour<sup>-1</sup> (1.3 tons day<sup>-1</sup>). Total storage of CO<sub>2</sub> on site is 40 tons.



**Figure 2.15** Plan view of KIM catchment showing the extent of the roofs and the separation between the control area in the uppermost part with the treated area (CO<sub>2</sub> + air warming) in the lower part of each catchment. At KIM this partition is a transparent and air-tight wall.

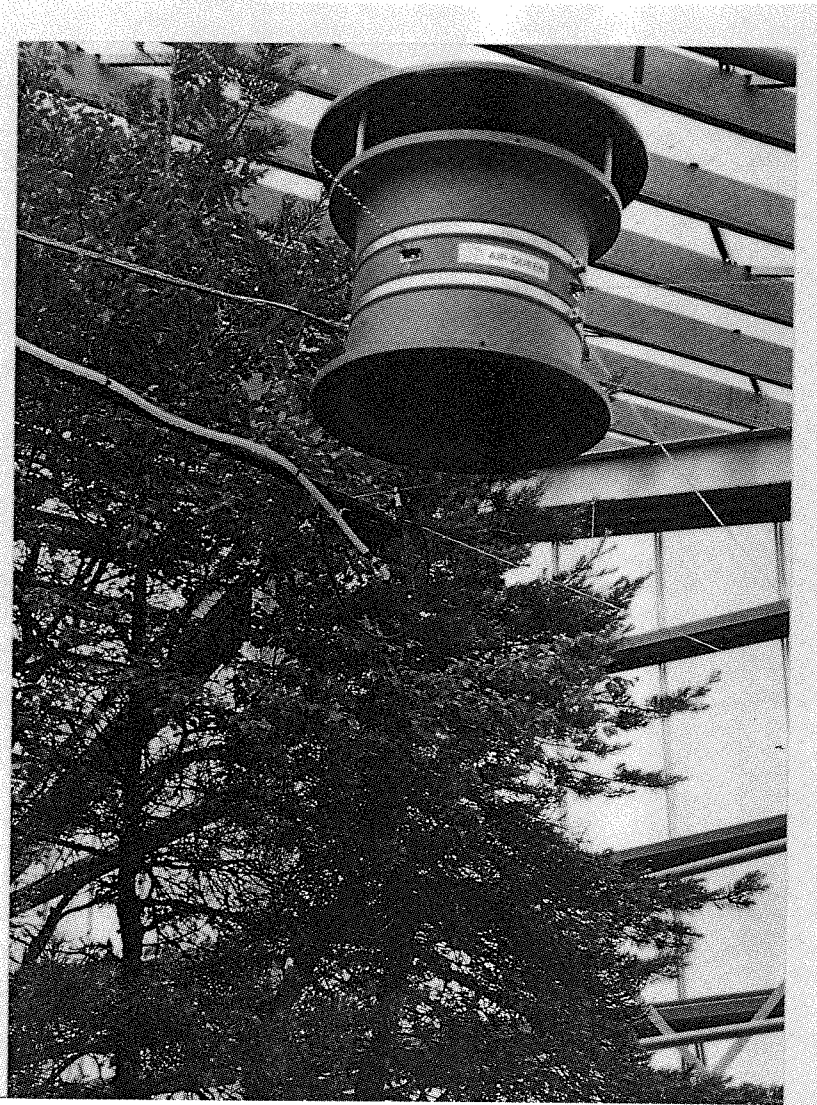


**Plate 2.1** CO<sub>2</sub> dosing in KIM catchment.

The air is warmed in the treatment section by means of a central heating system in which heated fluid is circulated through 3 ranks of 6 cm diameter steel pipes mounted on the insides of the walls around the entire treated section (Plate 2.3). A 75 kW electric furnace is used which is located in the control hut just outside the enclosure. Temperature is monitored continuously at 6 points. The target for air warming is +5°C above ambient in January and +3°C in July with intermediate temperatures in the intervening months (Figure 2.10). The targets are averages for the 6 measurement points.

Mixing of the air within both the treated and control sections is accomplished by means of large fans (6 in treatment and 2 in control) hung from the roof. These have a maximum capacity of 1000 m<sup>3</sup> hr<sup>-1</sup> and the speed is adjusted continuously to maintain an even temperature within each section. Ventilation (cooling) is by means of ranks of windows mounted along the entire length of the 4 sides of the structure. These can be opened to an angle of up to 45°.

Temperature and CO<sub>2</sub> dosing are automatically regulated by a climate computer. The computer doses CO<sub>2</sub> and regulates the electric furnace, degree of opening of the windows and speed of circulation fans to meet these criteria.

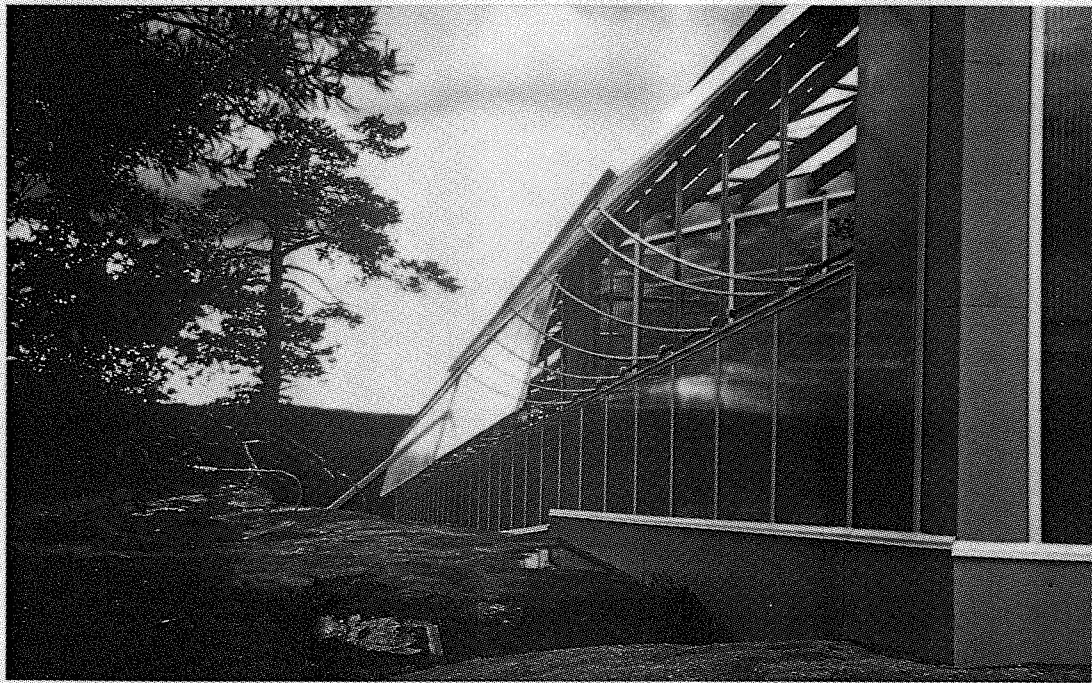


**Plate 2.2** CO<sub>2</sub> is added beneath recirculating fans.

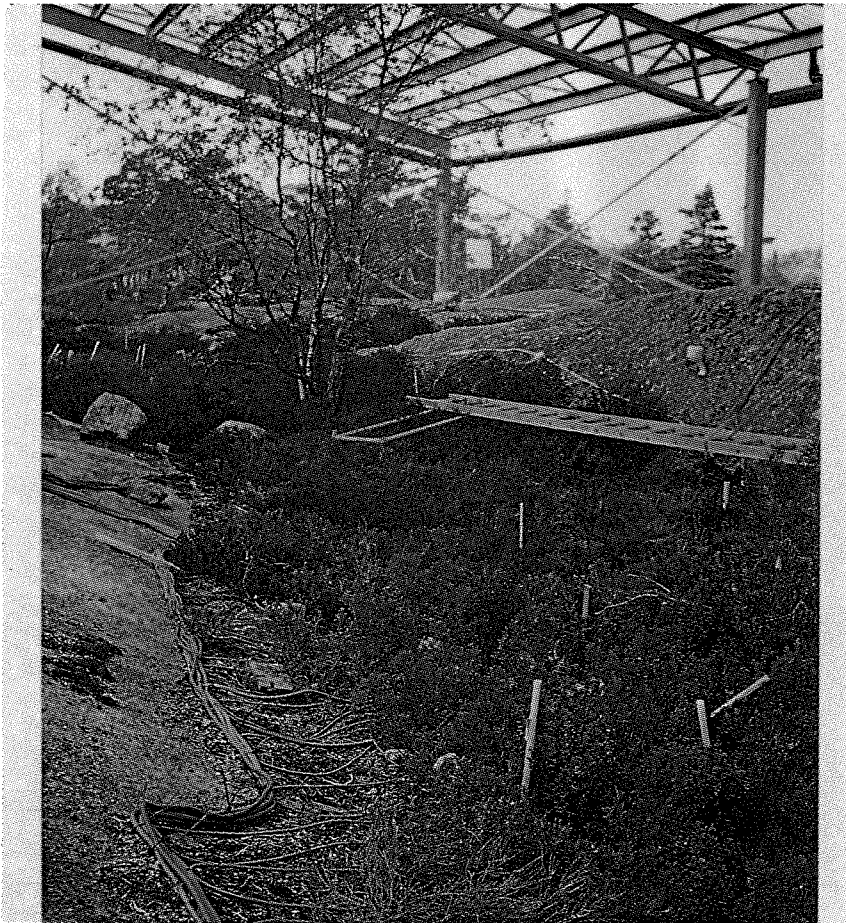
### *EGIL catchment: soil warming*

Soil warming at EGIL catchment is accomplished by means of electric heating cables placed on the soil surface beneath the litter layer (Plate 2.4). The heating system consists of 2 independent networks, the heating cable power system and the measurement and control system. Preliminary results show the cables are effective at maintaining a consistent temperature elevation across the span between cables and to successfully elevate temperature below the cables. Installation was carried out with minimal disturbance to the soil. The cables are spaced approximately 20 cm apart and were installed in autumn 1993 and May 1994 in the treatment part of EGIL (lower 80%) (Figure 2.16). The temperature is controlled by means of thermistors. A total of 120 thermistors is used, 66 in conjunction with the heating cables, 34 in the control area and 20 for measurements of air and soil temperature. The upper 20% of EGIL is left as an unheated control.

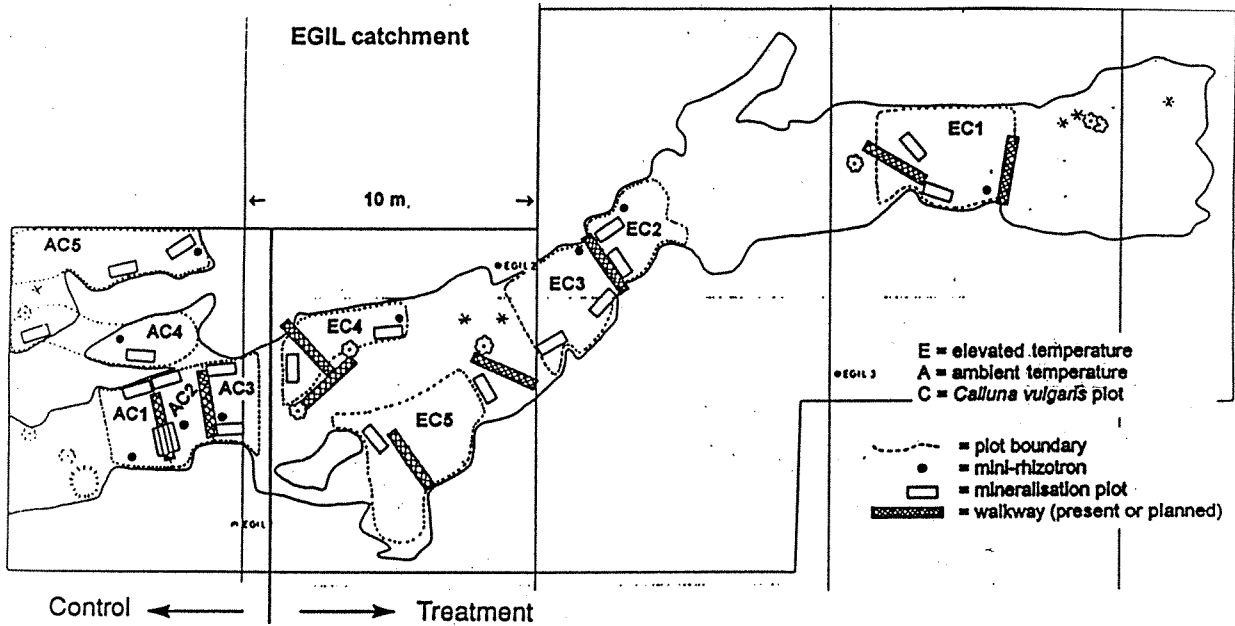
The experimental target for the soil warming is the same as at KIM catchment: +5°C above ambient soil temperature in January and +3°C in July, with intermediate temperatures in the intervening months.



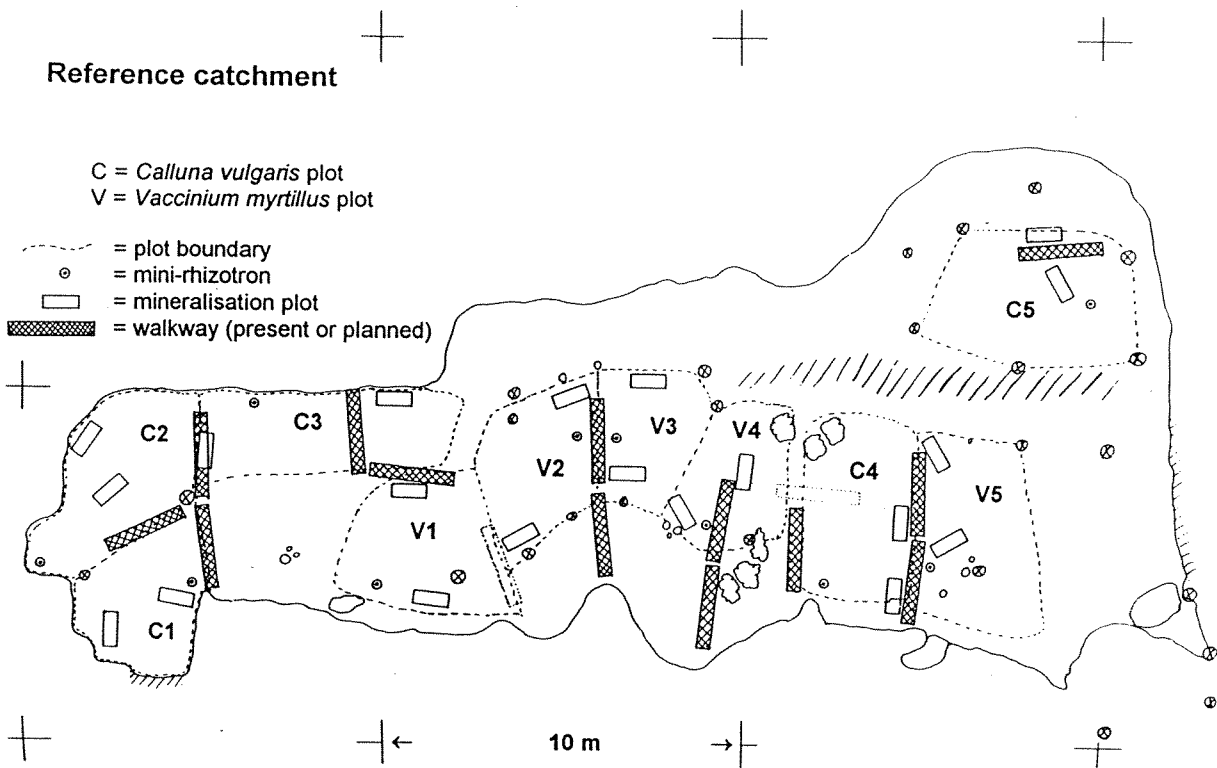
**Plate 2.3** Walls with heating pipes, one of these showing fans and open windows.



**Plate 2.4** Heating cables in EGIL.



**Figure 2.16** Plan view of EGIL catchment. There is no physical separation between the control and the treatment sections.



**Figure 2.17** Plan view of METTE catchment. There is no physical separation between the control and the treatment sections.

### *Control catchments*

Measurements in the control catchments are the same as in KIM and EGIL in the same vegetation types (Figure 2.17, METTE shown only).

### **4. References**

- Aune, B. 1993. National Atlas of Norway. Part 3. Air and Water. Statens kartverk, Hønefoss, Norway, 64 pp.
- Carpenter, S. R., Thomas, M. F., Heisey, D., and Kratz, T. K. Randomised intervention analysis and the interpretation of whole ecosystem experiments. *Ecology* 70(4), 1142-1152 pp.
- Lotse, E. 1989. Soil chemistry 1983-86 at the RAIN project catchments. Acid Rain Research Report 18/1989, Norwegian Inst. Water Research, Oslo, 66 pp.
- Lotse, E., and E. Otabbong. 1985. Physiochemical properties of soils at Risdalsheia and Sogndal. Acid Rain Research Report 8/1985, Norwegian Inst. Water Research, Oslo, 48 pp.
- Wohlfeil, I. C. and Müller, D. 1992. RAIN-PROJECT. Vegetation mapping at Risdalsheia 1991. Acid Rain Research Report 26/1992, Norwegian Inst. Water Research, Oslo, 42 pp.
- Wright, R.F. 1987. RAIN Project: annual report for 1986. Acid Rain Research Report 13/1987, Norwegian Institute for Water Research, Oslo. 90pp.
- Wright, R.F., E. Lotse, and A. Semb. 1988. Reversibility of acidification shown by whole-catchment experiments. *Nature* 334: 670-675.
- Wright, R.F., E. Lotse, and A. Semb. 1993. RAIN project: results after 8 years of experimentally reduced acid deposition to a whole catchment. *Can J. Fish. Aquat. Sci.* 50: 258-268.

# Chapter 3

## *Soil Water Monitoring and Hydrological Response*

---

R. Collins and A. Jenkins

Institute of Hydrology  
Wallingford, Oxon  
OX10 8BB  
United Kingdom

### **Summary**

Soil moisture status in KIM catchment is monitored continuously with time domain reflectometry (TDR) to determine plant-soil water response to the climatic manipulations. Tracer experiments within KIM utilising lithium bromide determine the hydrological response of the catchment to precipitation and enable investigation of the likely response to drier soils (predicted as a likely outcome of climate change). Application of a hydrological model to the catchments will describe water availability through time and test predictions of the impact of the CLIMEX manipulations on hydrological behaviour.

### **1. Introduction**

The soil water monitoring program within CLIMEX was set up to document changes in soil water storage within the experimental and control catchments and to assess the potential for long-term changes in catchment rainfall-runoff dynamics in response to climate change. The determination of water storage, or more importantly water availability, is crucial to interpret plant-soil responses to the manipulations. Hydrological and hydrochemical responses to storm events may also change in the long term if soil structure changes to affect flow pathways.

The impact of increased temperature and enriched CO<sub>2</sub> on runoff from forested catchments is difficult to predict. Transpiration is likely to decrease as the vegetation improves its water use efficiency in response to higher levels of atmospheric CO<sub>2</sub>. On the other hand, evapotranspiration will likely increase as a direct result of the higher temperatures. In any event, it is unlikely that a change in water flux or soil water storage could be immediately detected against the background of annual variation.

### **2. Research Methodology and Results**

#### *Soil Moisture Monitoring*

The establishment of a soil water monitoring system for the KIM catchment required automated instrumentation with good spatial and temporal resolution installed at a minimum

of disturbance to the catchment. In view of these requirements, the method of Time Domain Reflectometry (TDR) was chosen and installed in July 1993.

Measurement of soil water content with TDR is based on the attenuation of a voltage pulse sent through the soil. This attenuation depends upon the dielectric properties of the soil. Since the dielectric constant of water is 80, soil is 4 and air is 1, these properties are strongly influenced by water content. The dielectric content for ice is 3, enabling discrimination of frozen soil water. Topp et al. (1980) found an empirical polynomial relationship between volumetric soil water content and the dielectric constant based on measurements on a number of soil types, whilst Jacobsen and Schjønning (1993) found that the inclusion of linear terms for dry bulk density, clay content and organic matter slightly improved the calibration equation. This equation has been calibrated to the soils of Risdalsheia.

The voltage pulse is delivered to sensors arranged horizontally and vertically at different depths in the soil. Control files set up by the operator determine the timings of pulse activation enabling, for example, more frequent readings to be taken to identify the wetting of the catchment through a storm. Since the attenuation of the transmitted pulse is measured along the full length of the sensor, the resultant value for soil moisture is an averaged value over that distance. Thus, for sensors installed vertically, derived soil moisture values may be averaged over two or three soil horizons.

Thirty six sensors were installed throughout KIM catchment during August 1993, their location made with regard to topography, soil depth and vegetation (Figure 3.1) and to allow whole-catchment estimates of water storage. The sensors have three lengths: 0.1, 0.35 and 0.5m. The data obtained are stored on Oracle and the database is readily accessed and linked to the geographical information system Arc/Info utilising a suite of programs. We propose to instrument one of the reference catchments (METTE or CECILIE) with TDR probes in the future.

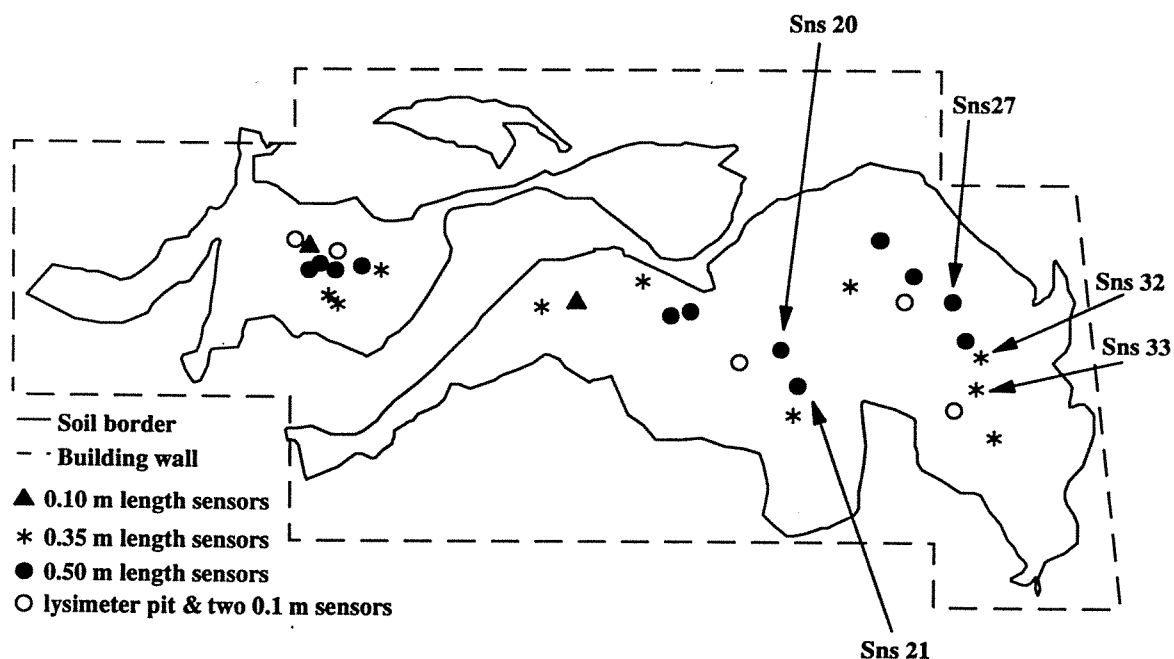
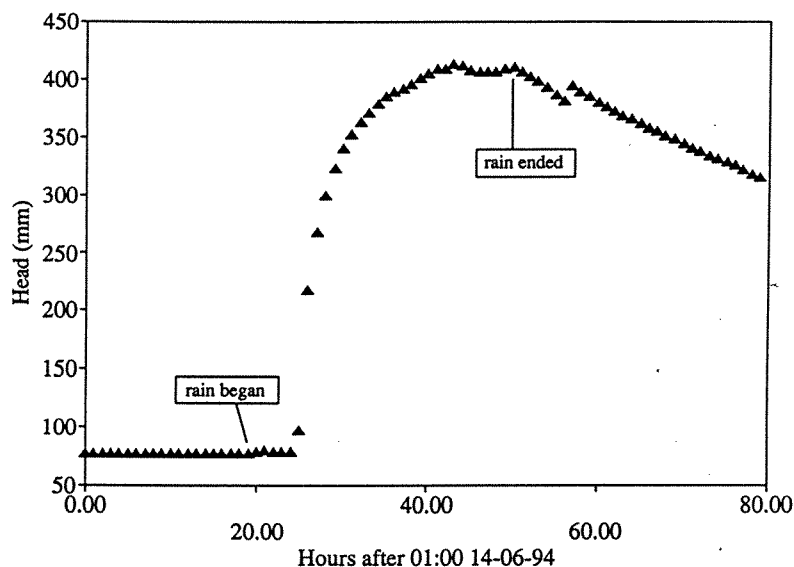


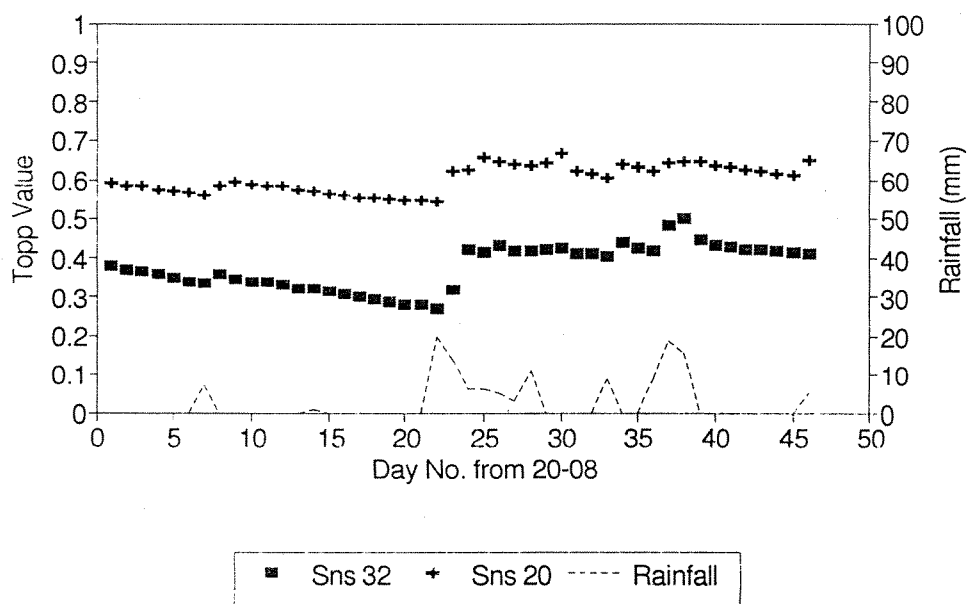
Figure 3.1 KIM Catchment - TDR sensor locations. Sensors discussed in the text are identified.



The TDR data is augmented in the area of deepest soils in KIM by measurement of a semi-permanent water table level using a piezometer installed in 70cm of soil. The shape of the bedrock "bowl" which permits this feature is well known from bedrock surface surveys. Figure 3.2 illustrates the wetting up of this bowl from a water table height of 7cm above the granite bedrock surface during a relatively dry period to 41cm after 23 hours of rainfall. At this time, the piezometer response and the input-output fluxes had reached a steady state. A gradual recession of the water table occurs, remaining relatively high for at least 28 hours after the event.



**Figure 3.2** Variation of the water table through a storm event.

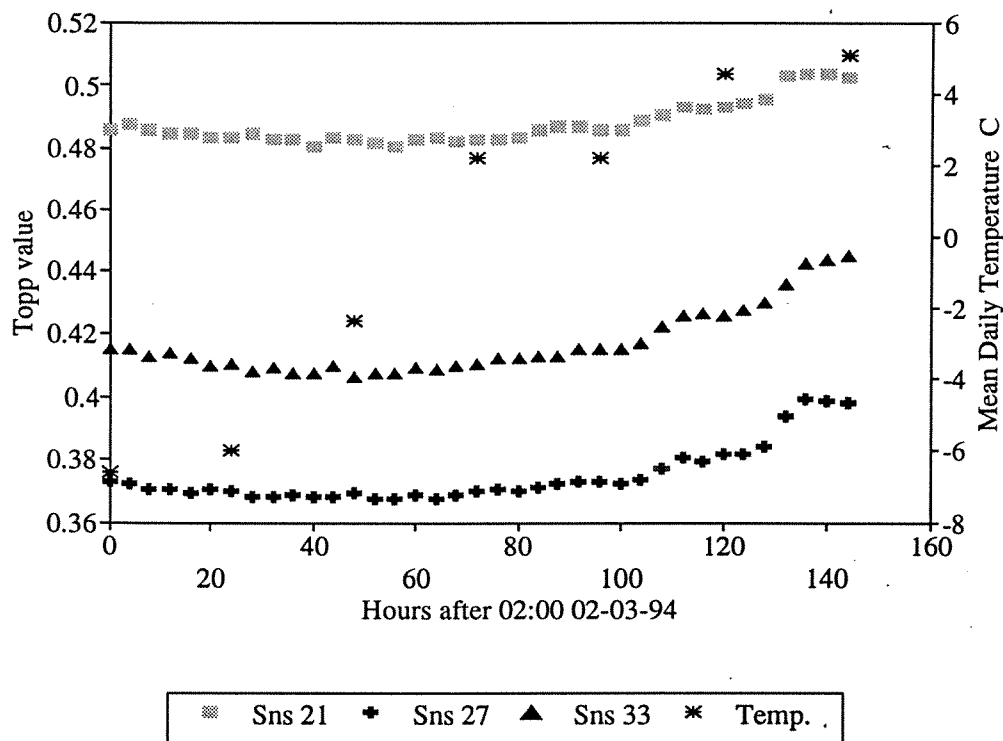


**Figure 3.3** Time series data for two sensors located in the lower slope region of KIM. Topp values are volumetric water content ( $m^3/m^3$ ). For reasons of clarity only one reading per day per sensor is illustrated. Sensor 20 = 50 cm probe; sensor 32 = 35 cm probe.

## Soil Moisture Time Series

Analysis of soil moisture time series from two sensors reveals the response of the soil to periods of wetting and drying and provides an indication of the effect of antecedent soil moisture in the generation of runoff (Figure 3.3). The time lag between the onset of rain and the initial sensor response and the nature of that response vary considerably throughout the catchment and are determined by a number of factors including initial soil moisture, depth of installation, topographical position and local soil and vegetation type.

The TDR sensors capture the response of KIM soils to spring snowmelt (Figure 3.4). Sub-zero air temperatures with no additional precipitation inputs resulted in a semi-frozen soil, with constant and relatively low Topp values (volumetric water content, expressed as  $m^3/m^3$ ) at each sensor location. The onset of above-zero temperatures led to gradual melting and a rise in soil moisture content.



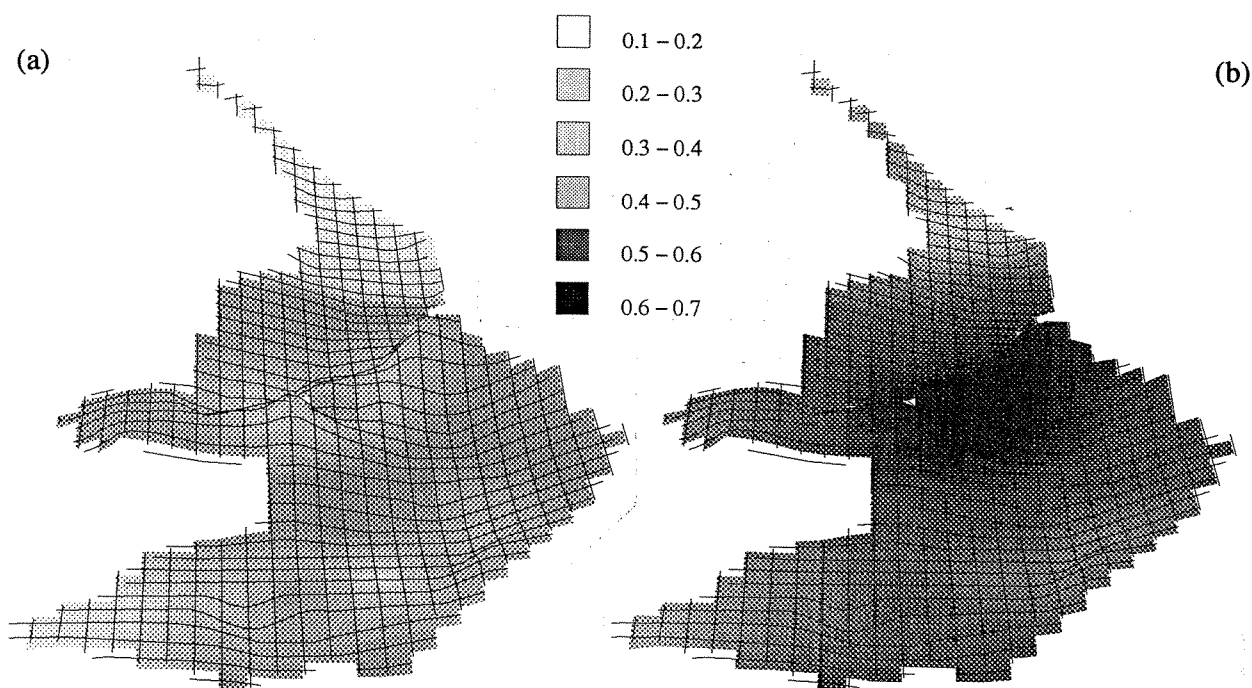
**Figure 3.4** The effect of temperature upon soil moisture content measured at three sensor locations in early March. Sensors 21 and 27 = 50 cm; Sensor 33 = 35 cm.

## Water Budgets

Catchment-scale estimation of soil water storage over time periods ranging from days to weeks is important in the interpretation of soil-plant responses to the experimental treatments. Such estimates require some method of lumping or interpolating measurements taken at a number of points. We employ the kriging technique at KIM to mathematically interpolate each point measurement of soil moisture (Figure 3.5). This enables calculation of a water balance for the entire catchment. Since soil moisture storage is measured by TDR, and rainfall inputs and runoff outputs are automatically logged, evapotranspiration is then the only remaining variable in the catchment water balance. These data also provide the catchment context for the small-scale transpiration measurements from vegetation (Chapter 8).

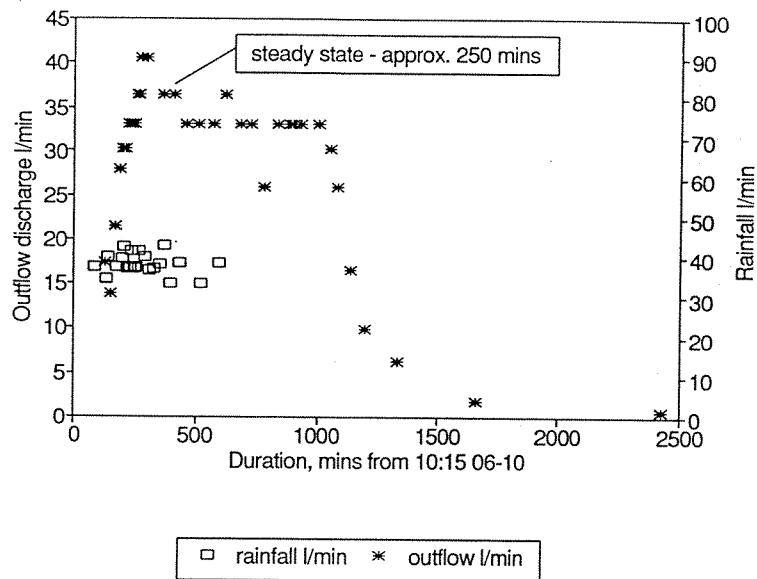
## Hydrological Response

The hydrological response of the catchment to precipitation events is assessed by tracer experiments. These involve adding a known concentration of lithium bromide to the water sprinkled on the catchment and monitoring the change in bromide ion concentration in runoff. A trial tracer experiment was conducted in October 1993. The catchment was first brought to a hydrological steady-state (rainfall input balanced by runoff) by sprinkling for two hours at maximum intensity before injection of the tracer. The tracer reached steady state very rapidly, suggesting high pore-water velocities possibly accentuated by bypass flow (Figure 3.6). However, a peak tracer concentration of 18% of the input level indicates that the storm hydrograph is dominated by old, thoroughly mixed water. Future monitoring of flow pathways with tracers will make use of the soil lysimeters installed in the catchment.

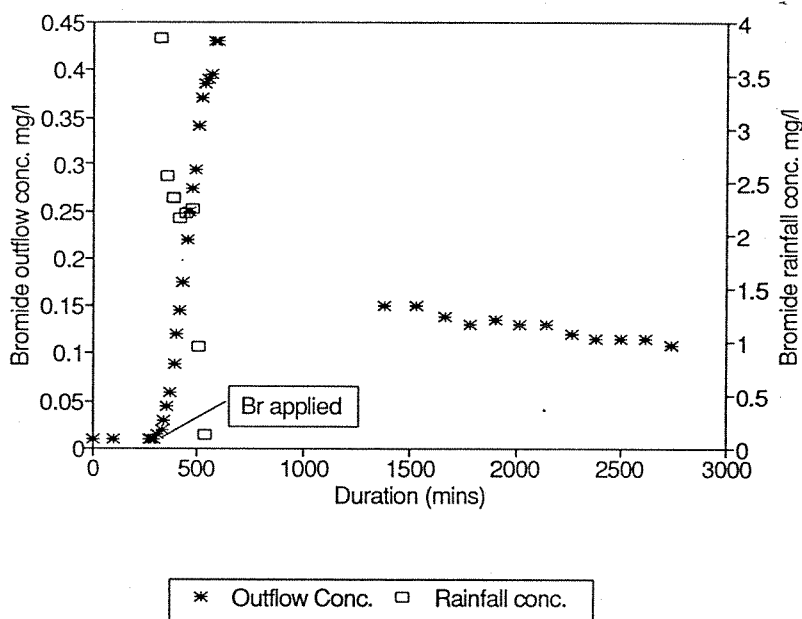


**Figure 3.5** Kriged soil moisture surfaces for the KIM catchment. Volumes are expressed as a volumetric water content ( $\text{m}^3/\text{m}^3$ ). (A) 13/06/94; low moisture status. (B) 16/06/94; near saturation.

We are unlikely to detect significant changes in soil moisture against the background of natural variability within the time scale expected for CLIMEX. It is possible, however, to study the hydrological response of the catchment to dry soils (expected to occur more frequently with climate change) by conducting a series of tracer experiments. We shall compare the runoff response to storms of similar intensity and duration but with progressively drier initial soil moisture conditions. As a soil dries out, pore-water flow velocity in subsequent storms may slow as flow pathways become more tortuous and flow depths change. Such increased residence times may modify runoff chemistry. Alternatively, drier soils may crack and enhance macropore flow, resulting in decreased residence time. The tracer experiments combined with TDR measurements will thus provide information on modified flow pathways and pore-water velocities. Soil water information provides a key input to the interpretation of observed changes in output fluxes (Chapter 4), plant litter decomposition rates (Chapters 5, 6 and 9), vegetation response (Chapters 5 and 8) and soil water chemistry (Chapter 6).



**Figure 3.6a** Rainfall and outflow discharge, KIM catchment 6-7 Oct. 1993

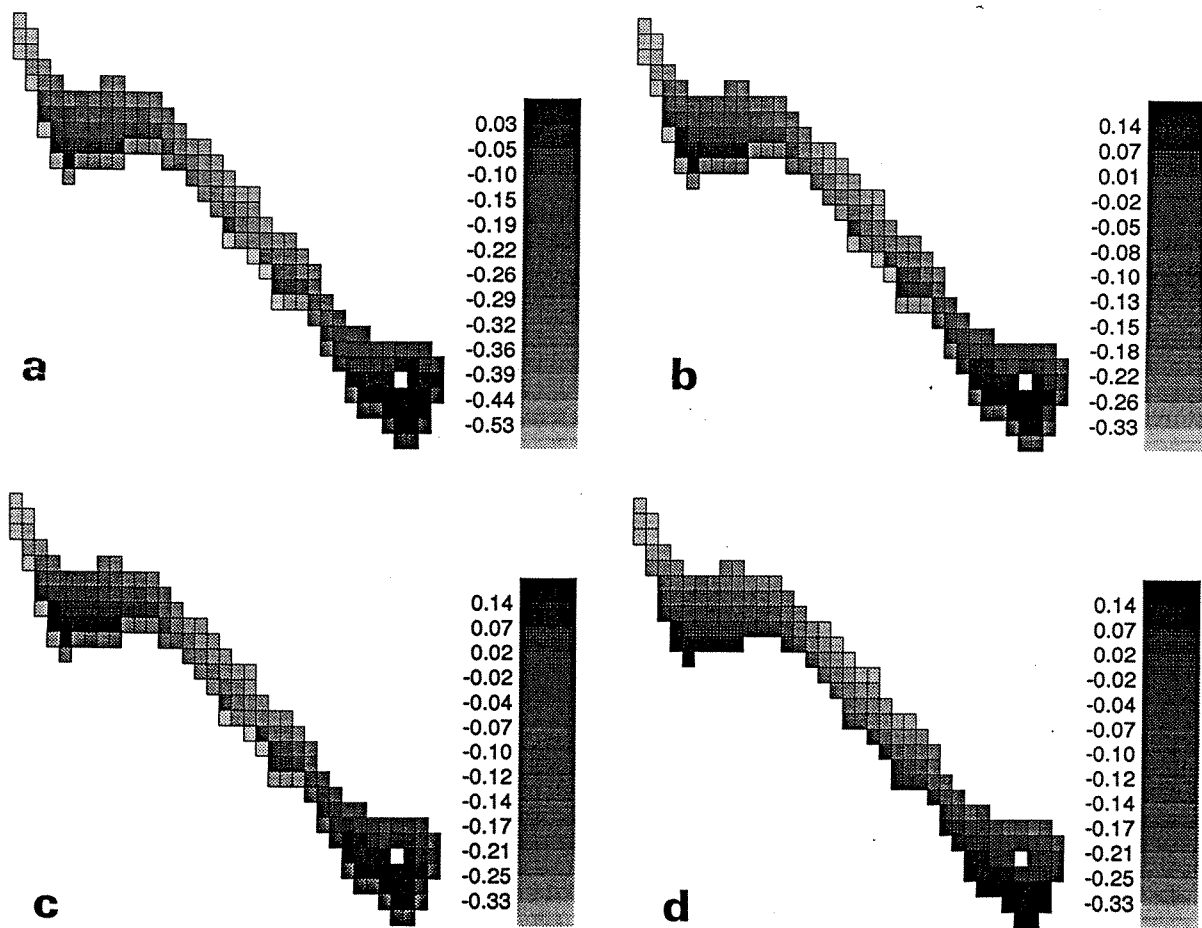


**Figure 3.6b** Bromide trace, KIM catchment 6-7 October 1993

### *Hydrological Modelling*

The Institute of Hydrology Distributed Model (IHDM), a physically based, distributed hillslope hydrological model, will be applied to KIM, EGIL and the reference catchment METTE. The model will be calibrated using measured soil physical characteristics, hourly rainfall and runoff and meteorological parameters from each of these sites. Once calibrated and validated against runoff, the model will be used to predict changes in soil moisture through time as driven by rainfall input. Soil moisture data derived from the TDR system will be used to further validate the model. The modelled soil water data is necessary to provide estimates from two of the three study catchments at any one time since only one TDR system is available.

The model has been tested against a short run of rainfall and runoff data from previous studies at EGIL. For the model application the catchment surface was divided into bare rock, *Calluna* and *Calluna* with trees. The nature of the vegetation determines evapotranspiration and hence effective rainfall to the soil surface. The physical representation of the catchment within the model was simplified to a single longitudinal hillslope transect through the catchment. The match between observed and simulated runoff is close. The dynamic changes in soil moisture predicted by the model indicate zones of temporary saturation around the outflow and in the upper parts of the catchment and but continued undersaturation, even at the peak of the storm, in the middle slope of the transect (Figure 3.7). The model required a very high saturated conductivity of 20 m hr<sup>-1</sup> to achieve a good match between observed and predicted runoff. As a comprehensive time series database describing rainfall, runoff and meteorological parameters is collected, the model will be applied and tested thoroughly.



**Figure 3.7** Soil water matric potentials at EGIL as predicted by IHDM for a single longitudinal hillslope transect at four time intervals through a storm; (a) T=3 hours, (b) T=33 hours, (c) T=35 hours and (d) T=45 hours. Soil matric potentials above zero indicate saturation and values below zero are unsaturated: the greater the negative number, the drier the soil. Note the change in scale for (a).

### 3. Time Scale of Measurements

Measurement of soil moisture status	continuing/ongoing
Estimation of catchment water budget	continuing/ongoing
TDR calibration	August 1994
Dry soil scenario tracer experiment	September 1994
Application of hydrologic model	Autumn 1994

### 4. Acknowledgements

Many staff at IH have helped and advised on this project, in particular the Instruments Section of the Institute of Hydrology who provided the piezometers and logger and Andrew Eatherall who installed the TDR system at KIM. We are indebted to Timo Heimovaara of the Department of Physical Geography, University of Amsterdam for his helpful and frequent advice with regard to operation of the TDR.

### 5. References

- Jacobsen, O.H. and Schjønning, P. 1993. A laboratory calibration of time domain reflectometry for soil water measurement including effects of bulk density and texture. *Journal of Hydrology* 151: 147-157.
- Topp, G.C., Davis, J.L. and Annan, A.P. 1980. Electromagnetic determination of soil water content: measurement in coaxial transmission lines. *Water Resources Research* 16: 574-582.

# Chapter 4

## *Input-Output Budgets*

---

Richard F. Wright

Norwegian Institute for Water Research  
Box 173 Kjelsås  
0411 Oslo, Norway

### **Summary**

Input-output budgets are measured at the 5 catchments to provide information on the catchment-scale integrated effect of the treatments. The measurements began in 1984 with the RAIN project; a total of 10 years of data are available from 3 catchments (KIM, EGIL, ROLF), and 1 year from the other 2 catchments (METTE and CECILIE). Wet precipitation is collected weekly; runoff is sampled 1-2 times weekly and discharge gauged continuously. Samples are analysed for major ions and nutrients. Dry deposition is estimated from air quality data collected at nearby Birkenes.

The input-output budgets from the 9 years of the RAIN project (June 1984 - June 1993) show a clear response to the exclusion of acid inputs at KIM catchment. Sulphate, nitrate and ammonium concentrations decreased in runoff, accompanied by lower levels of base cations, acid and inorganic aluminium. Acid neutralizing capacity increased. Comparison of EGIL and ROLF catchments indicate no large roof effect.

These trends continued during the CLIMEX background year May 1993 - April 1994. The 2 new untreated reference catchments have, in most aspects, similar runoff chemistry to that of ROLF.

### **1. Introduction**

The flux of energy and matter across ecosystem boundaries gives an integrated measure of the whole-ecosystem response to environmental perturbation. For the CLIMEX project, changes in fluxes of water and dissolved components in runoff provide information on the catchment-scale effects of the experimentally-altered CO<sub>2</sub> and temperature regime as well as a direct measure of the effects on aquatic ecosystems of changes in terrestrial catchments. A central objective of CLIMEX, then, is to accurately measure the water and chemical fluxes in precipitation and runoff at the 5 catchments at Risdalsheia.

Input-output budgets were the major focus of the RAIN project, and routine measurements at three of these catchments (KIM, roof/clean rain; EGIL, roof/acid rain; ROLF, no roof/acid rain) have been carried out since winter 1984. The runoff chemistry observed at KIM catchment relative to EGIL and ROLF catchments over the 10-year experimental period show major change due to the greatly reduced inputs of strong acids (Wright et al. 1988, 1993).

The experimental procedures of CLIMEX largely follow those of the RAIN project. New for CLIMEX is the inclusion of 2 additional untreated reference catchments, called METTE and CECILIE. Together the 3 reference catchments provide an estimate of the natural

catchment-to-catchment variation with which the changes in runoff chemistry and fluxes from the two manipulated catchments can be compared.

Here the input-output budgets and runoff chemistry for the 10-year RAIN project period at three catchments and for the pre-treatment period December 1992 - December 1993 at all 5 CLIMEX catchments are presented. Data from the pre-treatment period are also summarised in the Appendix at the end of this chapter.

## 2. Methods

### *Precipitation Volume*

At the two roofed catchments (KIM and EGIL) the volume of sprinkled water is metered and read at (minimum) weekly intervals. For the three reference catchments (ROLF, METTE, CECILIE) precipitation is collected by funnel and volume is measured weekly at the meteorological station located in an open area at Risdalsheia. Since 1992 daily measurements of precipitation volume, solar radiation, soil temperature and air temperature (maximum, mean and minimum) are also measured at this point.

### *Dry Deposition*

Dry deposition is estimated from average concentrations of  $\text{SO}_2$  and  $\text{NO}_x$  gases and  $\text{SO}_4$  particles measured daily at the nearby EMEP station at Birkenes. We use deposition velocities for these species of 0.7, 0.25, and 0.4 cm/s, respectively. Dry deposition of marine aerosol is calculated by difference from the Cl flux in runoff minus the Cl flux in bulk precipitation at each catchment (Wright et al. 1993).

### *Precipitation Chemistry*

Chemical composition of ambient precipitation outside the roofs is determined on bulk samples collected weekly from the funnel at the meteorological station. Samples are sent to NIVA (prior to 1993 to NILU Norwegian Institute for Air Research) for analysis of pH, electrical conductance, Ca, Mg, Na, K,  $\text{NH}_4$ ,  $\text{NO}_3$ , Cl, and  $\text{SO}_4$  by methods summarized in Table 4.1.

### *Runoff Discharge*

All runoff from the catchments is collected at fibreglass dams at the bottom of each catchment and removed by hose to 500 l tanks which empty automatically when full. Discharge is measured by logging the number of tanks emptied. Samples for chemical analysis are collected automatically at about weekly intervals from each full tank (or a pre-set selection of tanks). These systems at Risdalsheia have been in continuous operation since March 1984 (KIM and EGIL), October 1984 (ROLF) and May 1993 (METTE and CECILIE).

### *Runoff Chemistry*

Runoff samples are analyzed at NIVA for pH, electrical conductance, Ca, Mg, Na, K,  $\text{NH}_4$ ,  $\text{NO}_3$ , Cl,  $\text{SO}_4$ , aluminum species (reactive-Al and organic-Al), total organic carbon, total



nitrogen, total phosphorus, silica and fluoride by methods given in Table 4.1. Inorganic monomeric Al species are defined as the difference between reactive-Al (RAI) and organic-Al (ILAI). Organic anions (A<sup>-</sup>) are calculated by difference from the ionic balance. Acid neutralizing capacity (ANC) is defined as the equivalent sum of base cations (SBC = Ca, Mg, Na, K, NH<sub>4</sub>) minus the equivalent sum of strong acid anions (SSA = NO<sub>3</sub>, Cl, SO<sub>4</sub>). Non-marine fraction (denoted by asterisk) is calculated in the usual manner by subtracting the marine fraction (assumed to be all of the Cl<sup>-</sup> and for the other ions their ratios to Cl<sup>-</sup> in seawater).

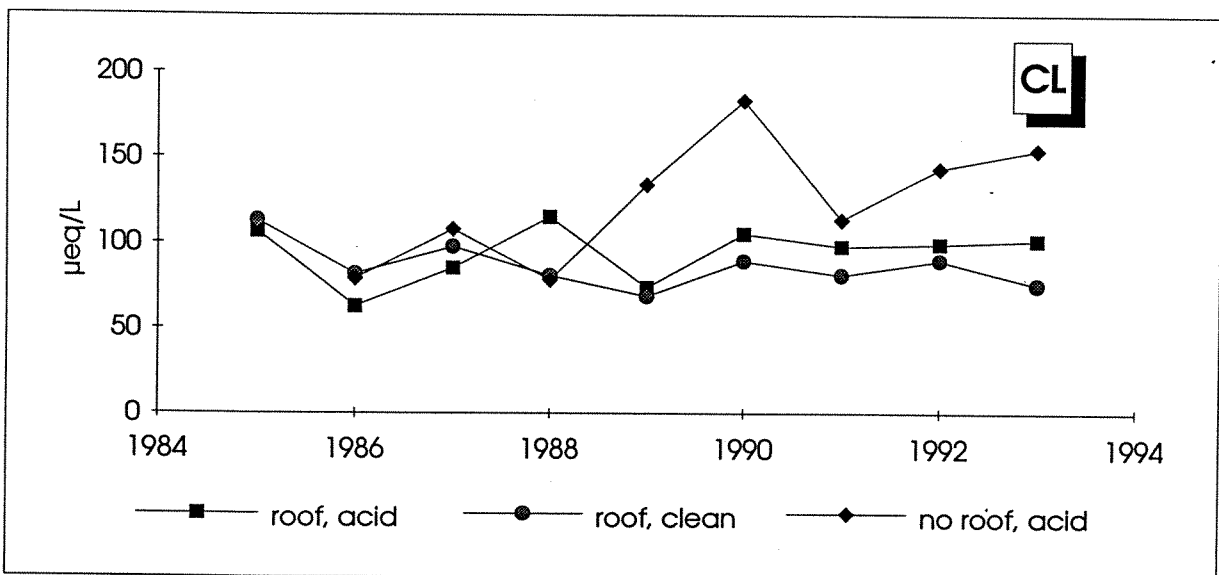
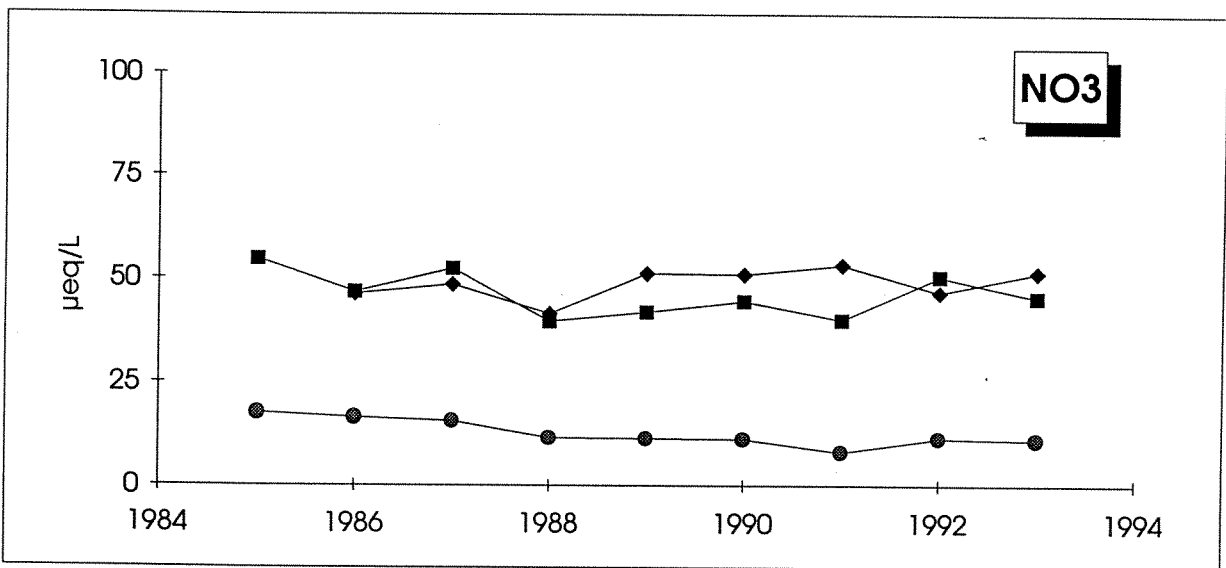
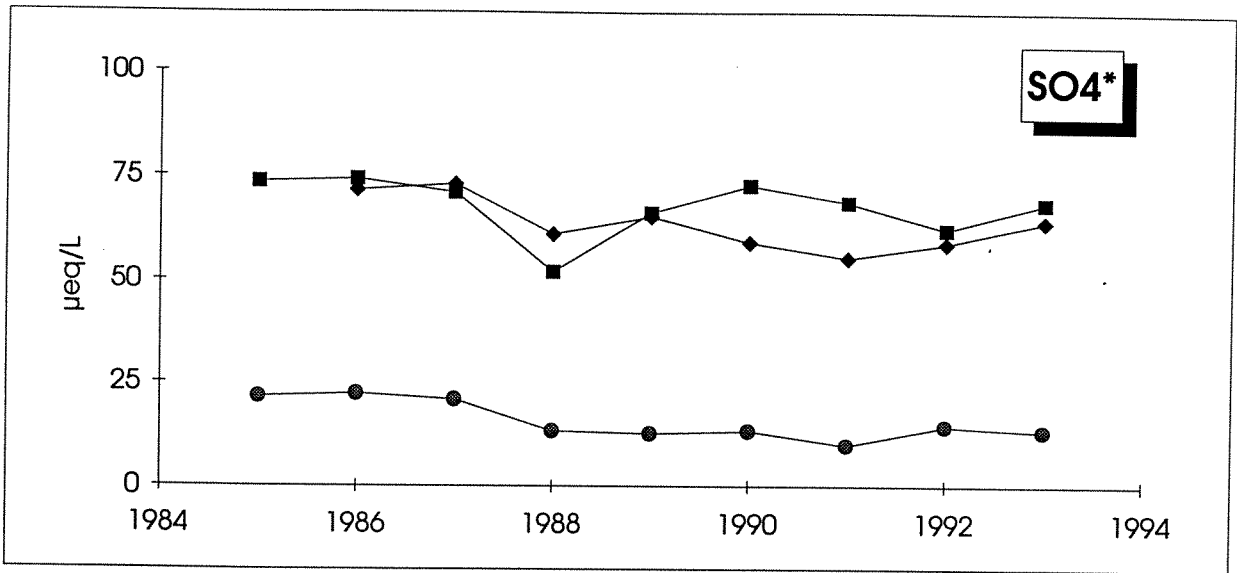
**Table 4.1** Analytical methods used for precipitation (P) and runoff (R) samples at NIVA

Parameter	Sample type	Method	Detection limit	Standard error
pH	P, R	potentiometry	0.01	0.05
Na	P, R	ICP	0.02 mg/l	0.06
Ca	P, R	ICP	0.02 mg/l	0.01
Mg	P, R	ICP	0.003 mg/l	0.04
K	P, R	atomic adsorption spectrophotometry	0.02 mg/l	0.01
NH <sub>4</sub> -N	P, R	automated colorimetry	5 µgN/l	5
NO <sub>3</sub> -N	P, R	automated colorimetry	1 µgN/l	2
Cl	P, R	ion chromatography (IC)	0.2 mg/l	0.08
SO <sub>4</sub>	P, R	ion chromatography	0.2 mg/l	0.12
react-Al	R	automated colorimetry	10 µg/l	3
org-Al	R	cation exchange, automated colorimetry	10 µg/l	3
TOC	R	oxidation, spectrophotometry	0.2 mgC/l	0.01
Tot-N	R	oxidation, automated colorimetry	5 µgN/l	5
Tot-P	R	oxidation, automated colorimetry	1 µgP/l	0.2
SiO <sub>2</sub>	R	automated colorimetry	0.1 mg/l	0.16
F	R	potentiometry, ion-specific electrode	0.1 mg/l	0.08

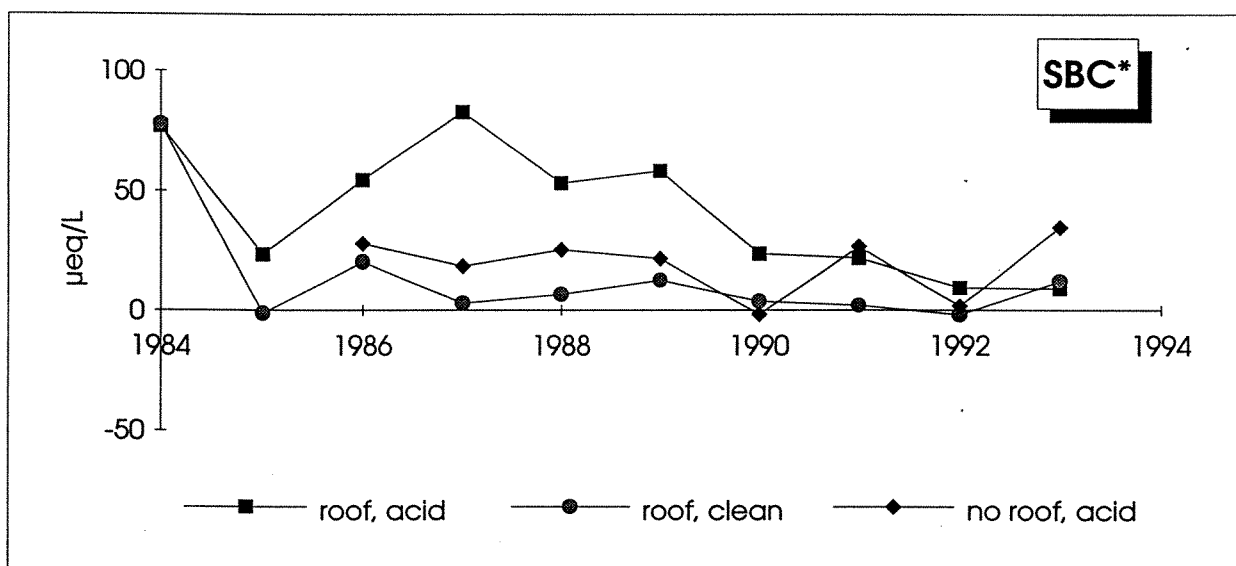
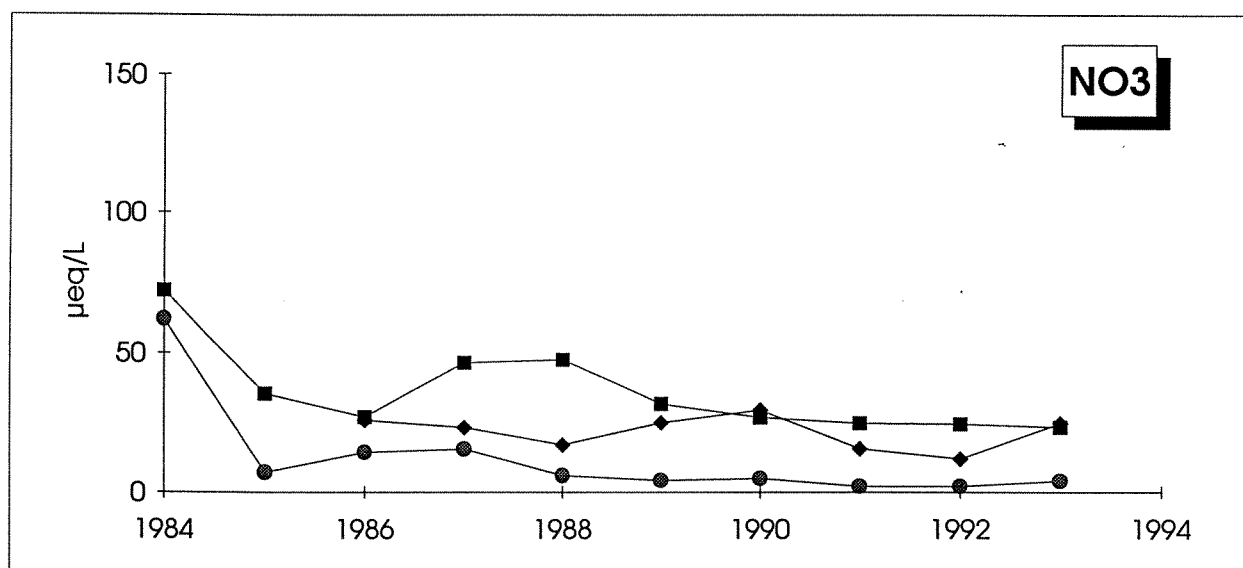
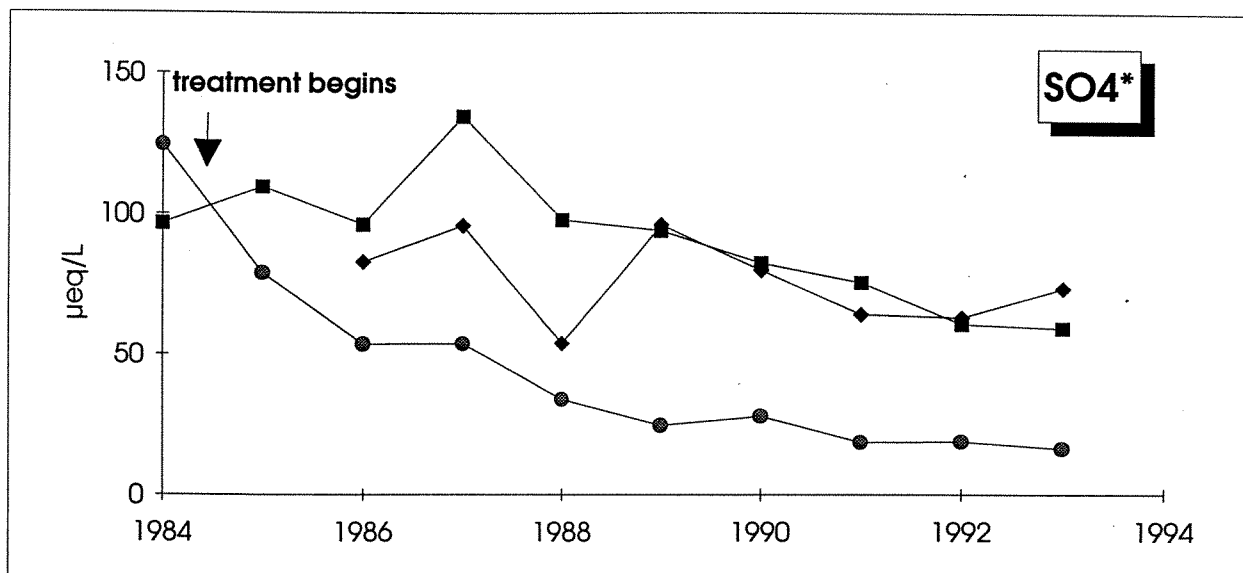
### 3. Results and Discussion

#### *Long-Term Results*

The experimental setup successfully removed most of the pollutant ions from deposition at KIM catchment. Sulphate and nitrate concentrations in deposition (wet and dry) were reduced to levels about 1/4 of those in ambient deposition (Figure 4.1). Differences in Cl concentrations in deposition are largely due to lower dry deposition of seasalts under the roofs.



**Figure 4.1** Volume-weighted average concentrations of non-marine sulphate (top panel), nitrate (middle panel), and chloride (lower panel) in total deposition (wet plus dry) at Risdalsheia (data from Wright et al. 1993).



**Figure 4.2** Volume-weighted average concentrations of non-marine sulphate (top panel), nitrate (middle panel), and non-marine base cations (lower panel) in runoff at Risdalsheia (data from Wright et al. 1993).

The 10-year record of runoff chemistry at Risdalsheia shows major changes due to the reduced deposition of acid under the roof at KIM catchment (Table 4.2, Figure 4.2) (Wright et al. 1988, 1993). Concentrations of nitrate decreased within weeks to volume-weighted mean levels of < 10 µeq/l, compared with 33 µeq/l in runoff at EGIL catchment (roof, acid rain) and 26 µeq/l at ROLF catchment (no roof, acid rain) (Figure 4.2). Sulphate concentrations also decreased dramatically, but the decrease was gradual over several years (Figure 4.2). Runoff from the roofed, clean catchment contained only 25 µeq/l (non-marine sulphate 16 µeq/l) in 1992-93, the 9th year of treatment, compared with an average 71 µeq/l in runoff from the roofed, acid catchment and 93 µeq/l from the open catchment.

**Table 4.2** Deposition (wet + dry) and runoff fluxes (8-year average) for major components at Risdalsheia (not seasalt corrected). SBC = sum base cations (Na, K, Ca, Mg NH<sub>4</sub>); SSA = sum strong acid anions (NO<sub>3</sub>, Cl, SO<sub>4</sub>); ANC = acid neutralising capacity (SBC - SSA). Units: meq/m<sup>2</sup>/yr, TOC and SiO<sub>2</sub> mmole/m<sup>2</sup>/yr.

	KIM (roof, clean)		EGIL (roof, acid)		ROLF (no roof, acid)	
	IN	OUT	IN	OUT	IN	OUT
H <sub>2</sub> O (mm)	990	881	1101	1031	1455	1255
H <sup>+</sup>	32	59	80	85	100	110
Na	67	69	87	91	145	143
K	2	5	4	6	6	6
Ca	4	8	9	17	14	19
Mg	16	12	21	24	35	32
Al	0	8	0	15	0	15
NH <sub>4</sub>	6	5	39	18	57	10
NO <sub>3</sub>	12	5	50	33	70	26
Cl	84	84	103	103	169	169
SO <sub>4</sub>	23	38	84	104	109	112
A <sup>-</sup>	6	38	3	14	9	29
SBC	106	98	160	155	257	211
SSA	125	127	237	240	348	307
ANC	-19	-29	-77	-85	-91	-96
TOC		1057		809		1166
SiO <sub>2</sub>		38		39		37

These decreases in concentrations of strong acid anions were accompanied by changes in concentrations of major cations and organic anions. Concentrations of the non-marine fractions of the base cations Na<sup>+</sup>, K<sup>+</sup>, Ca<sup>2+</sup> and Mg<sup>2+</sup> were lower in runoff from the roofed, clean KIM catchment than in runoff from both the acid catchments (Figure 4.2).

Acid neutralizing capacity (ANC) increased as a result of the acid exclusion. Mean volume-weighted average concentrations in runoff increased from -88 µeq/l to -7 µeq/l over the 9 years of treatment (Figure 4.3). This increase parallels the decrease in concentrations of strong acid anions.

Although ANC increased dramatically,  $H^+$  has decreased only moderately, from about 83  $\mu\text{eq/l}$  to 56  $\mu\text{eq/l}$  (Figure 4.3). pH is thus still low. Much of the increase in alkalinity was balanced by increases in the concentrations of organic anions (Figure 4.4). Natural organic acids apparently dissociated to an increasing extent as the experiment proceeded, thus buffering pH. The concentration of total organic carbon (TOC) in runoff did not change; rather the charge density (defined as the  $\mu\text{eq}$  of organic anions per mg TOC) increased. This increase appeared to level off after about 4 years of treatment.

During this 9-year period there has also been a general long-term decline in ambient sulphur deposition at EGIL and ROLF catchments (Figure 4.1). This trend is a result of reduced emissions of sulphur in Europe during the 1980's. The runoff data from EGIL and ROLF catchments thus also show a modest decline in sulphate concentrations (Figure 4.2) accompanied by a slight increase in ANC (Figure 4.3).

### *Background Year*

The final year of the RAIN project (December 1992 - December 1993) represents the pre-treatment background year for CLIMEX. Here the annual mean levels as well as the seasonal patterns in runoff chemistry are given, against which any forthcoming changes due to the  $\text{CO}_2$  and temperature manipulations will be evaluated.

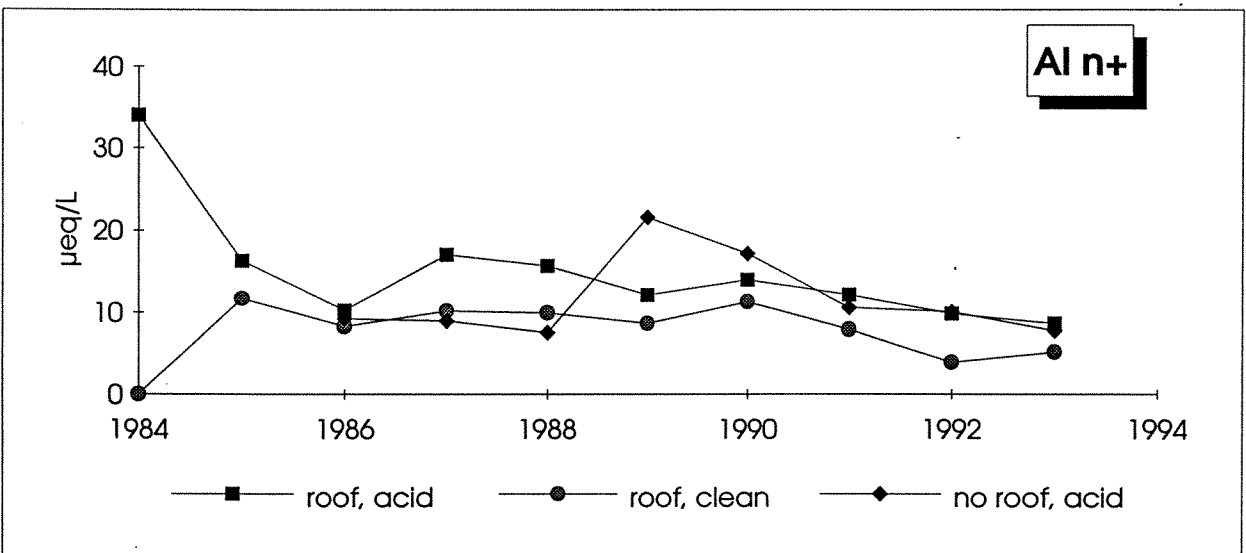
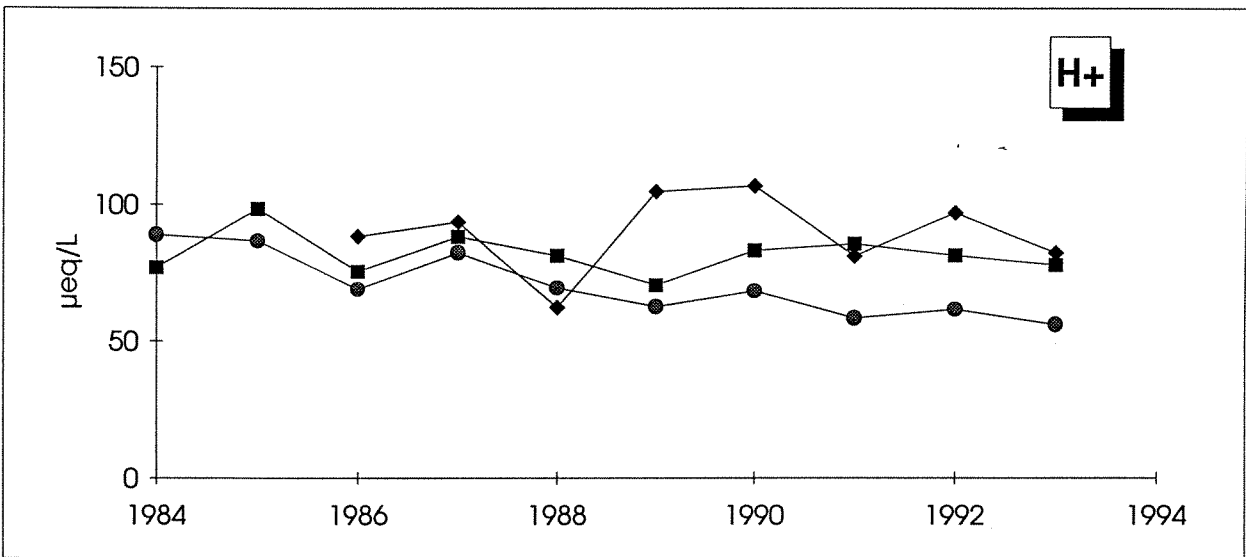
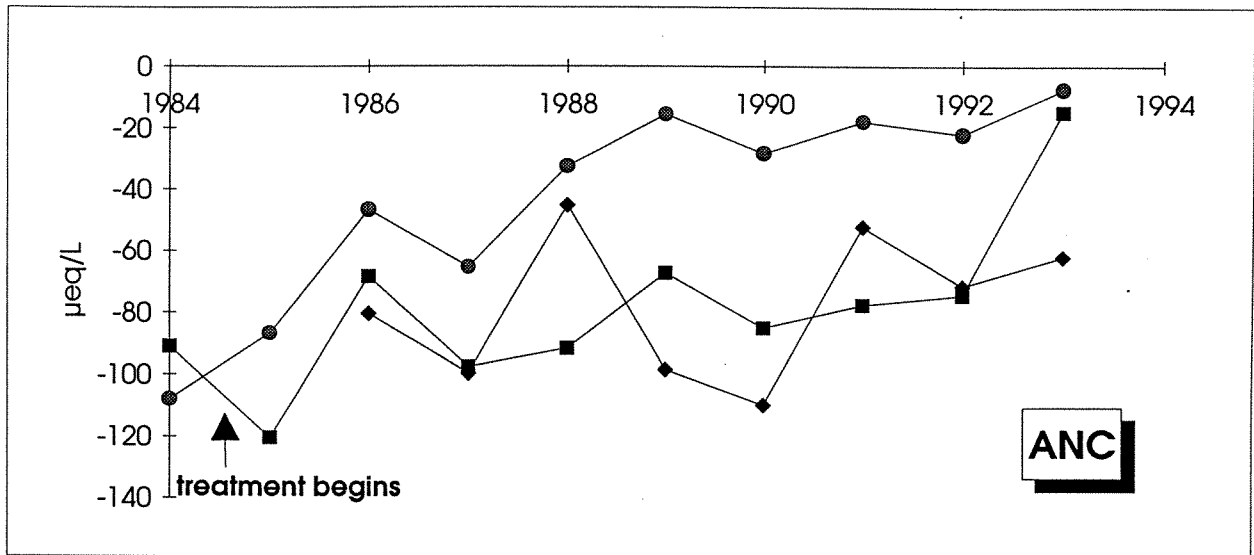
The chemical composition of runoff exhibits clear seasonal patterns despite large sample-to-sample variations related mainly to hydrological conditions. Analysis of these patterns again begins with the strong acid anions. Sulphate concentrations in runoff were high in the first runoff following the dry period from mid-May to mid-July, probably due to oxidation of stored sulphur (Figure 4.5). Sulphate levels decline in subsequent runoff. This effect is exhibited in all catchments, including KIM which has received very low inputs of sulphur over the past 10 years.

Chloride, the other major anion in both precipitation and runoff at Risdalsheia, also shows seasonal patterns, but these are related to the occurrence of storm events with high winds which bring high concentrations of seasalts into the atmosphere. Such storms are more frequent during the winter and thus chloride concentrations in precipitation are typically about 1.5 to 2 times higher during the winter than in the summer. In particular January 1993 was a month of several extremely intense seasalt events in southern Norway. The impact of these is quite evident at Risdalsheia, with high levels of Cl in precipitation and runoff (Figure 4.5).

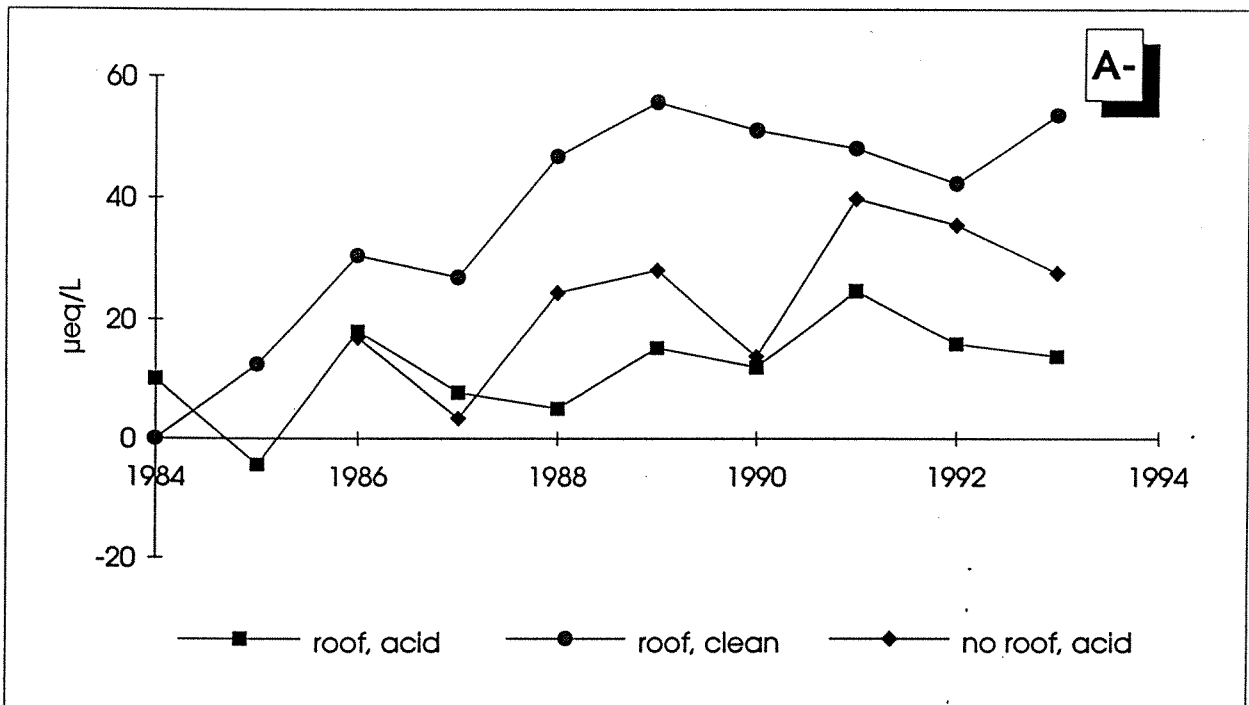
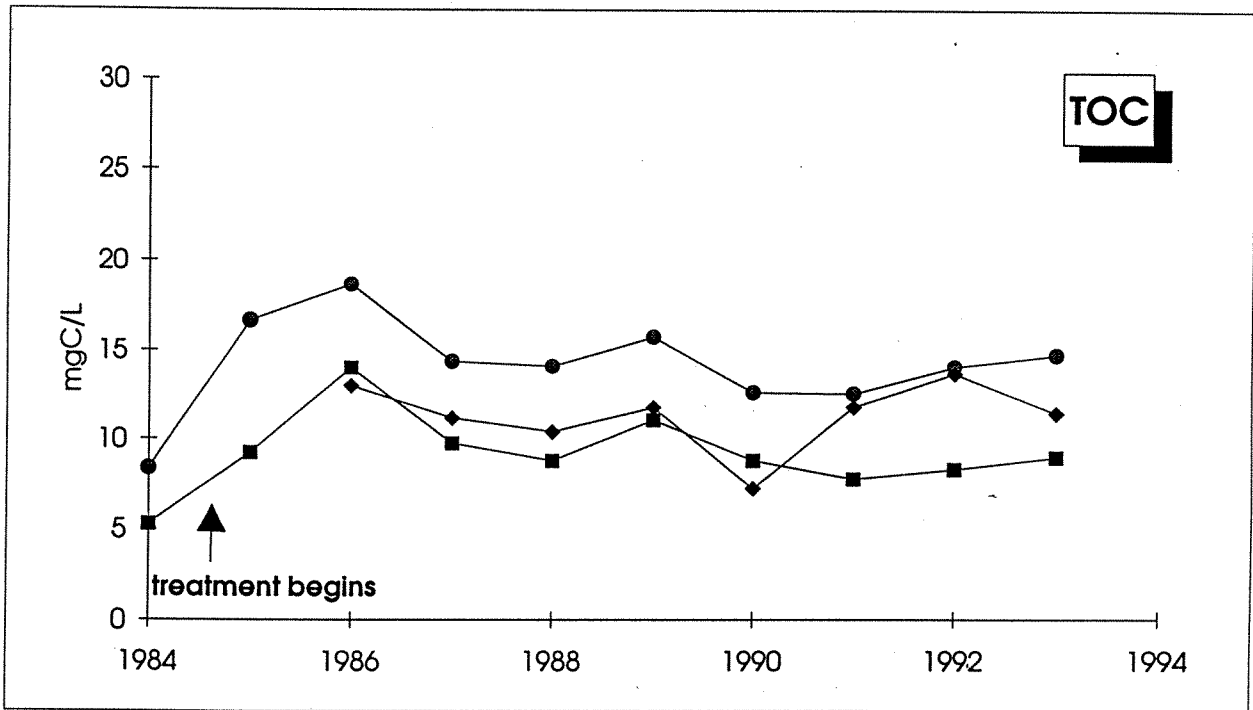
The concentrations of cations largely follows the patterns set by the levels of these 2 major anions. The non-marine fraction of base cations (SBC\*) largely follows the pattern set by sulphate in runoff (Figure 4.5).

Concentrations of nitrate in runoff also are high in the first runoff following dry periods, but in addition there is a clear seasonal pattern of high concentrations during the winter half-year and low concentrations during the summer half-year (Figure 4.6). The release following dry periods is probably due to mineralization of nitrogen stored in the soil. The lower levels during the summer are probably due to uptake by vegetation. The winter-summer seasonal pattern is most pronounced in the 4 catchments receiving high inputs of nitrogen deposition. At KIM catchment inputs are very low, and it appears that the soil and vegetation retain most of the incoming nitrogen.

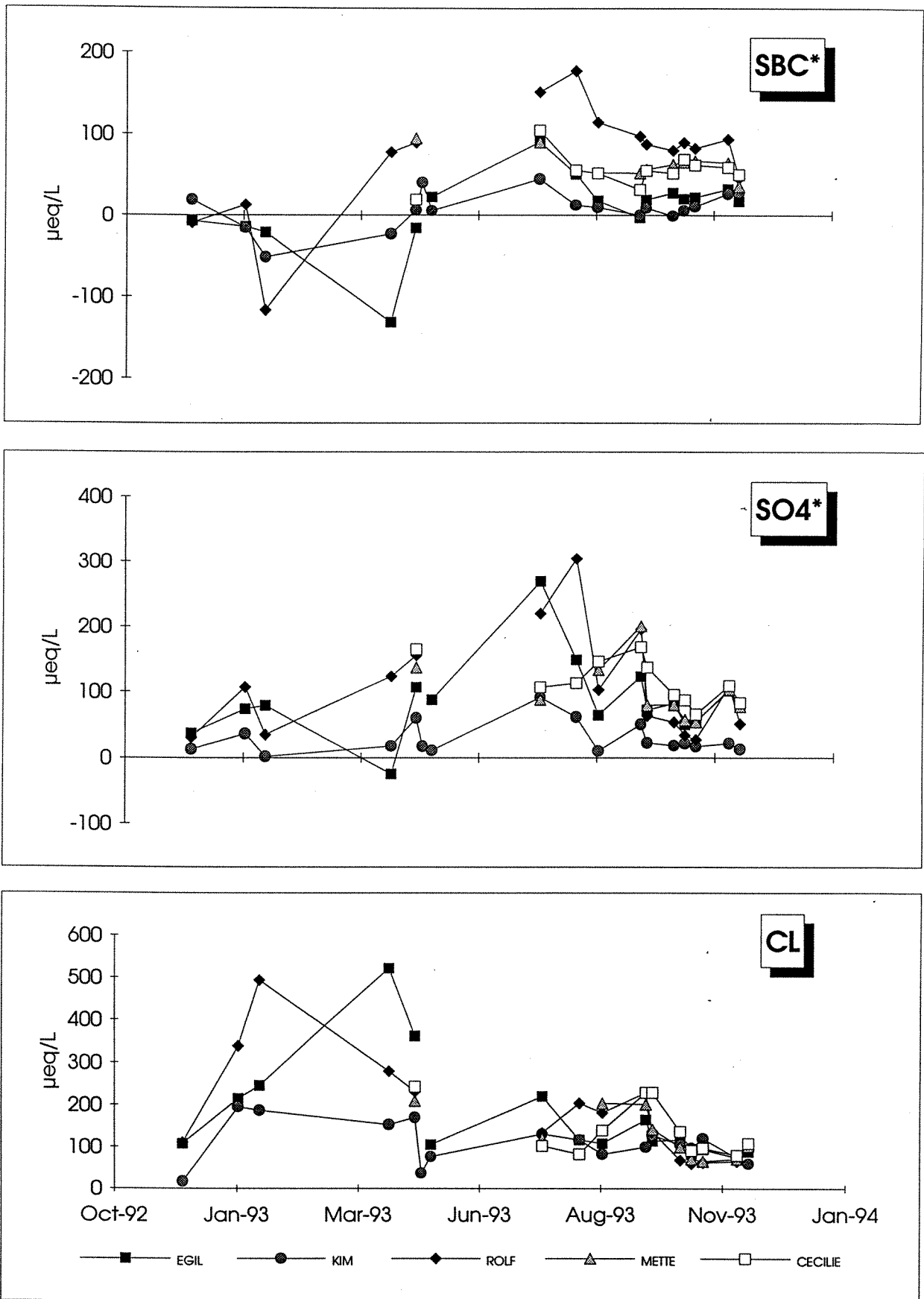
Ammonium follows approximately the same pattern as nitrate, although at lower concentrations (Figure 4.6). At the catchments receiving ambient ammonium deposition the first runoff after dry periods often contains relatively high concentrations of ammonium. At the clean rain catchment KIM, ammonium levels are usually very low.



**Figure 4.3** Volume-weighted average concentrations of H<sup>+</sup> (top panel) and acid neutralizing capacity (ANC) (defined as equivalent sum of base cations minus equivalent sum of strong acid anions) (lower panel) in runoff at Risdalsheia (data from Wright et al. 1993).

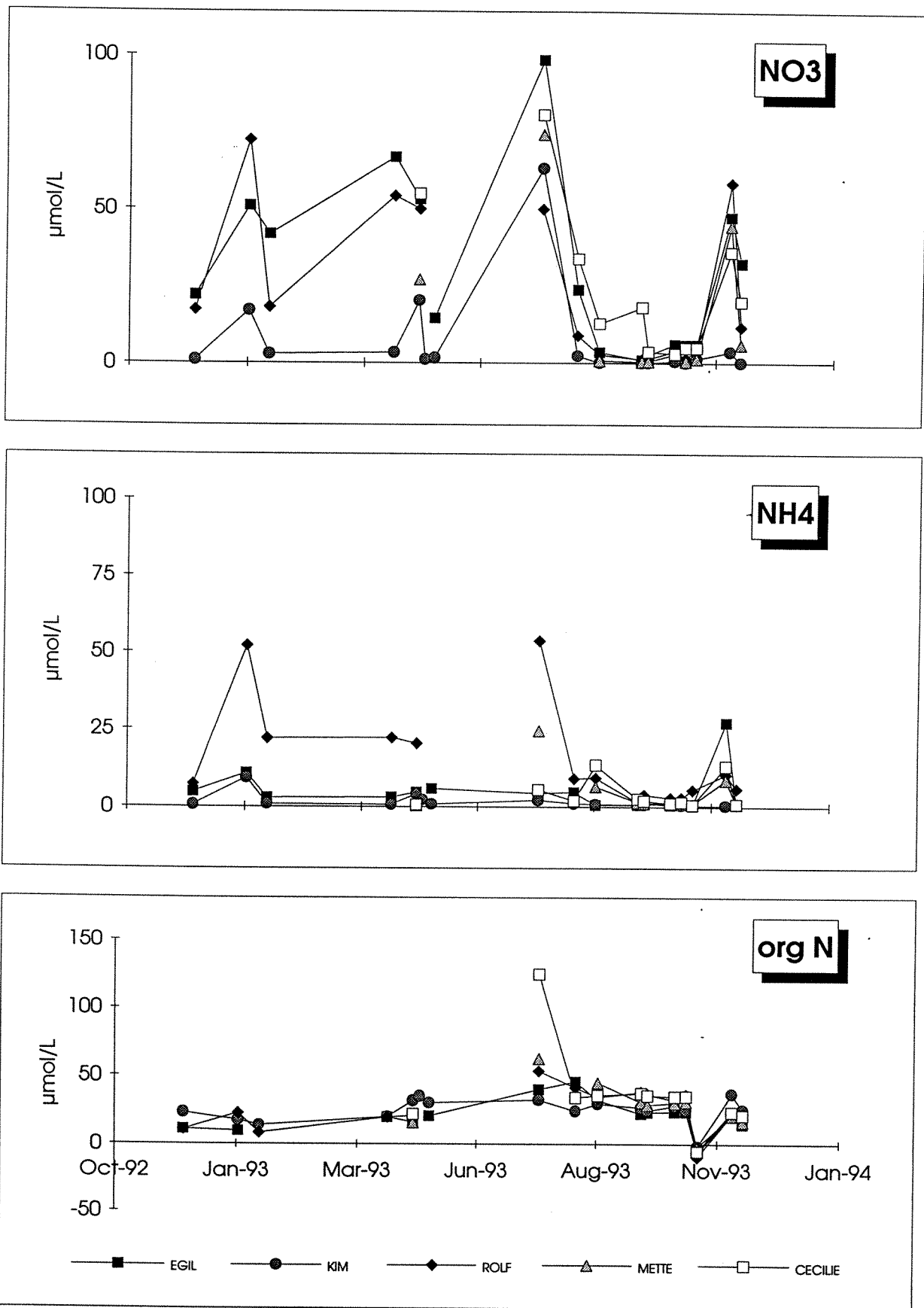


**Figure 4.4** Volume-weighted average concentrations of total organic carbon (TOC) (top panel) and organic anions (defined as equivalent sum of measured cations minus equivalent sum of measured anions (lower panel) in runoff at Risdalsheia (data from Wright et al. 1993).

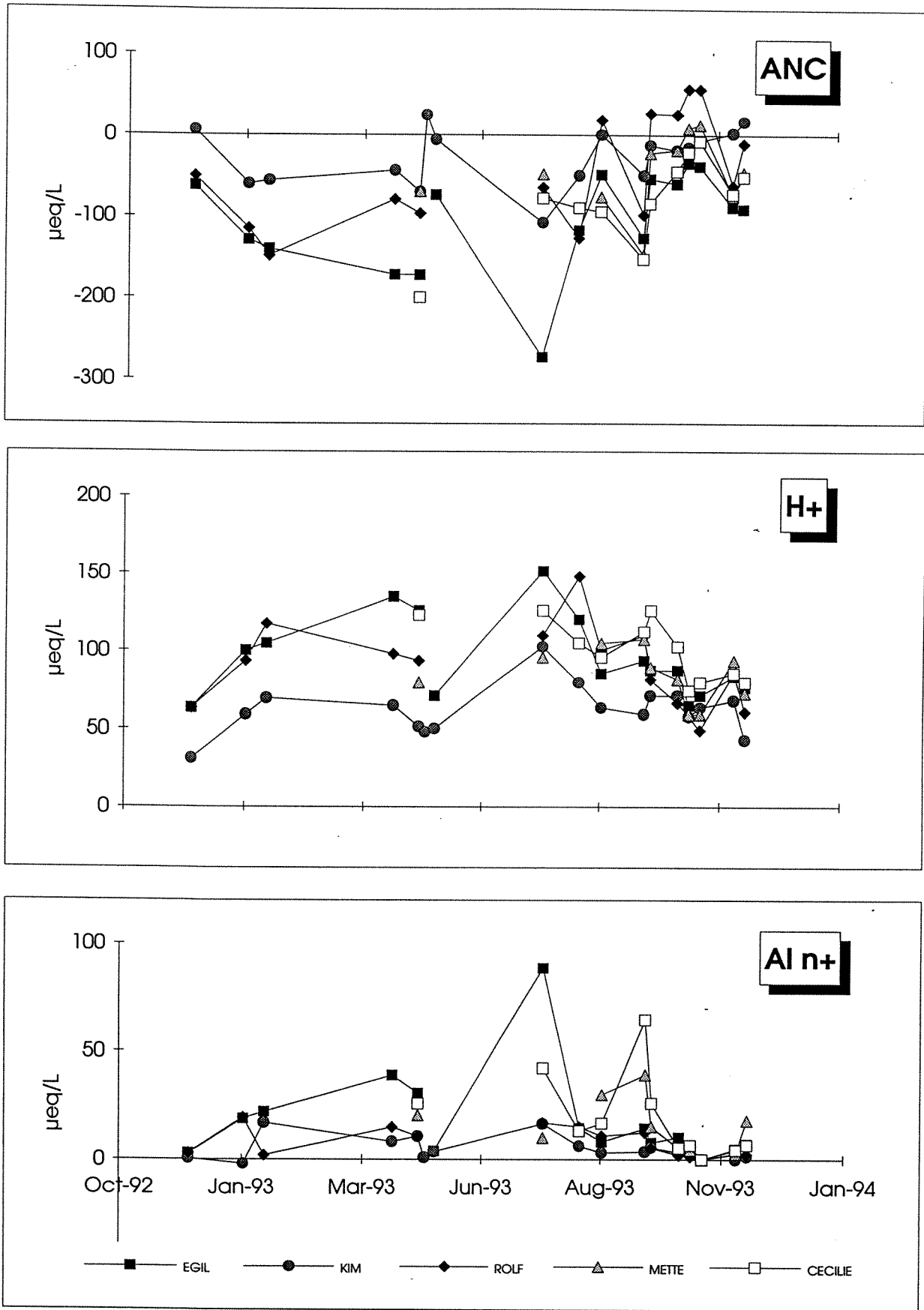


**Figure 4.5** Concentrations of sulphate (top panel), non-marine base cations (middle panel), and chloride (lower panel) in runoff at 5 catchments at Risdalsheia December 1992 - December 1993.

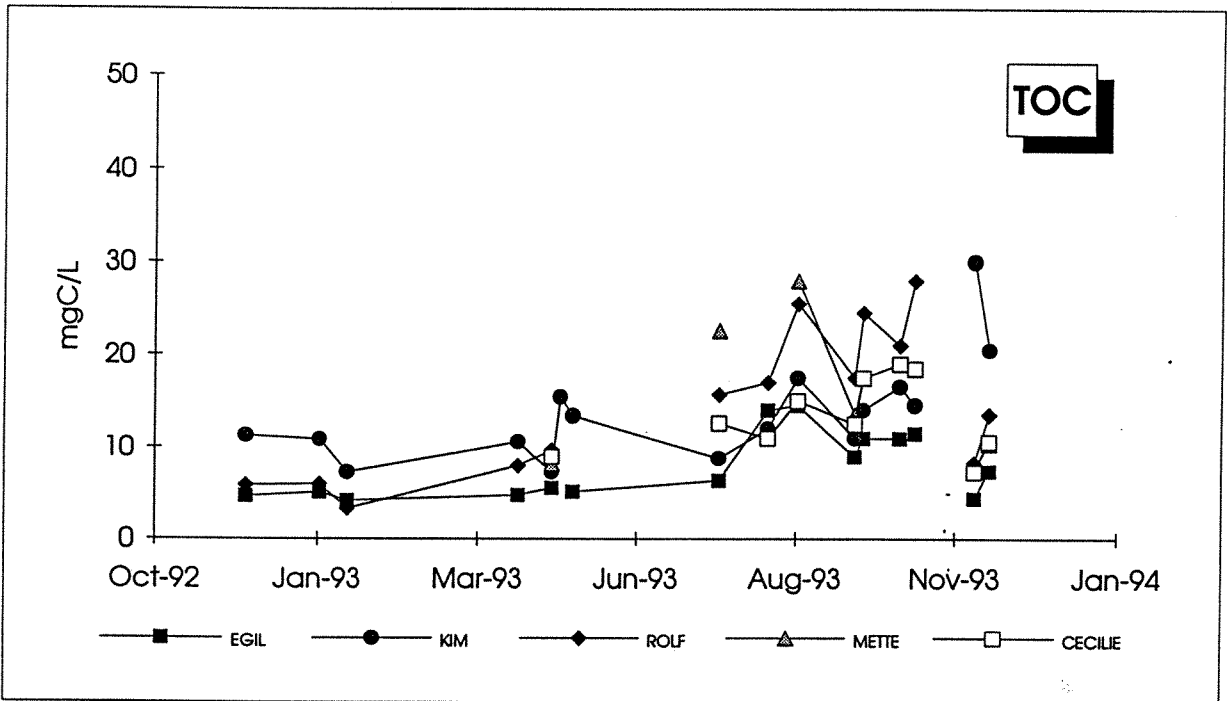
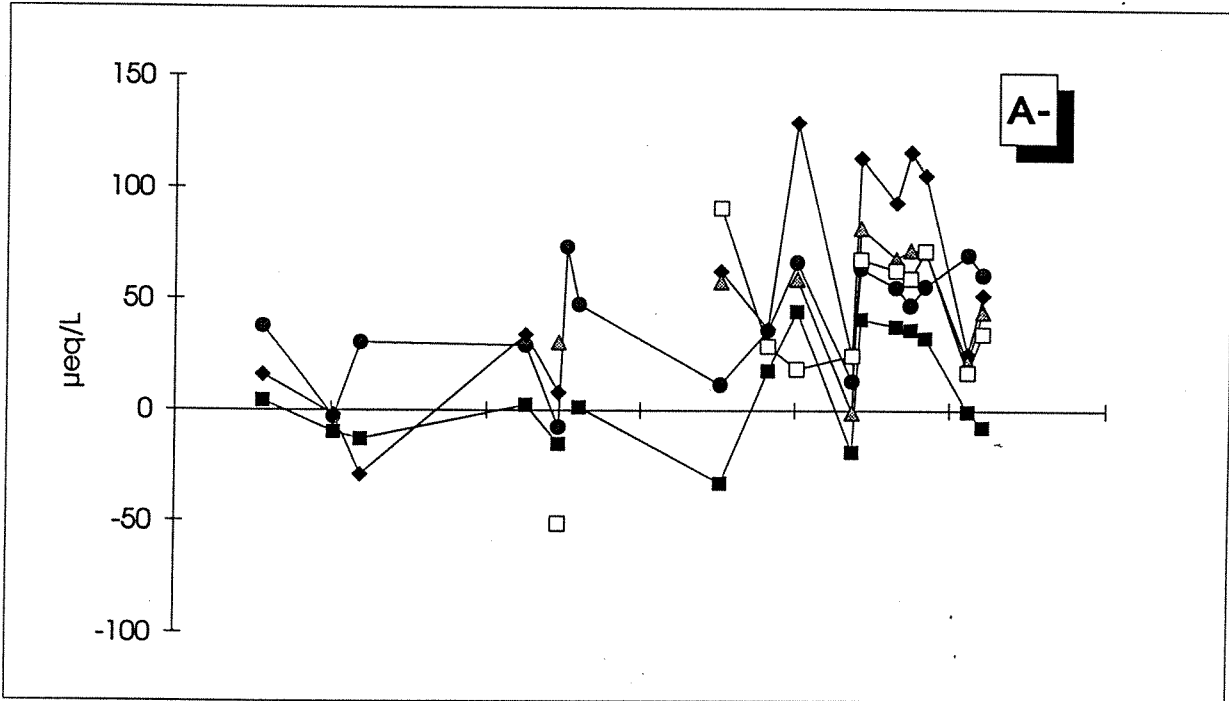




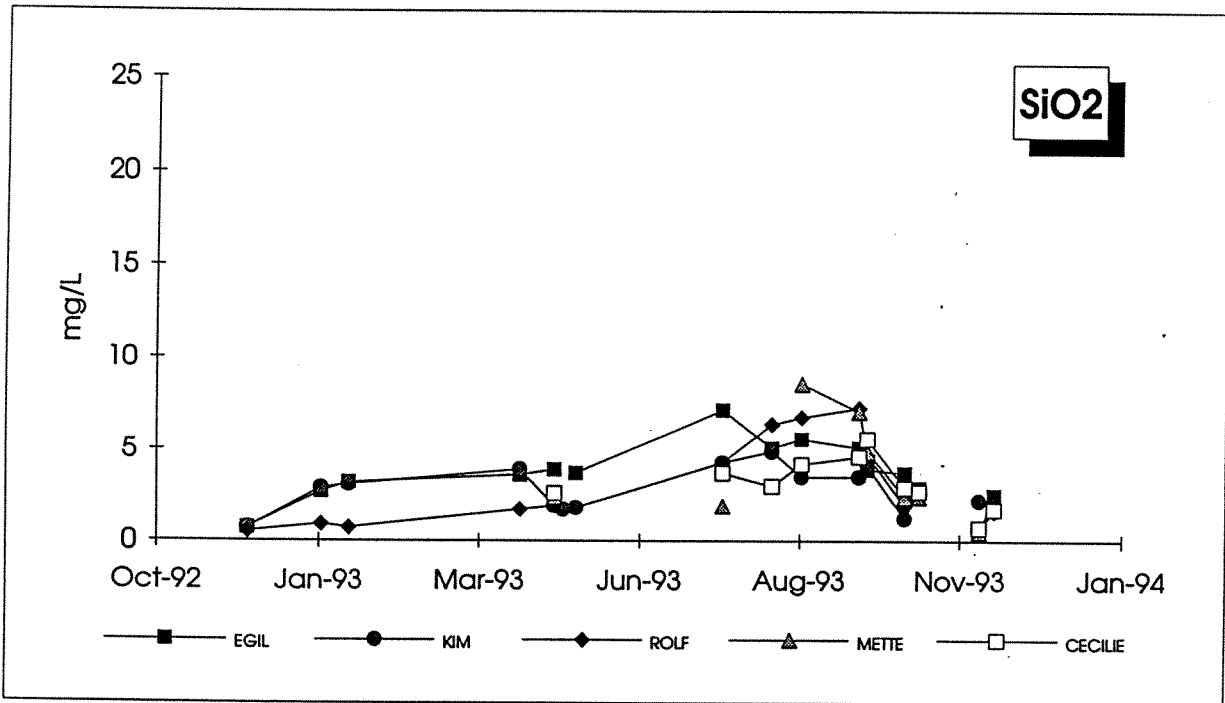
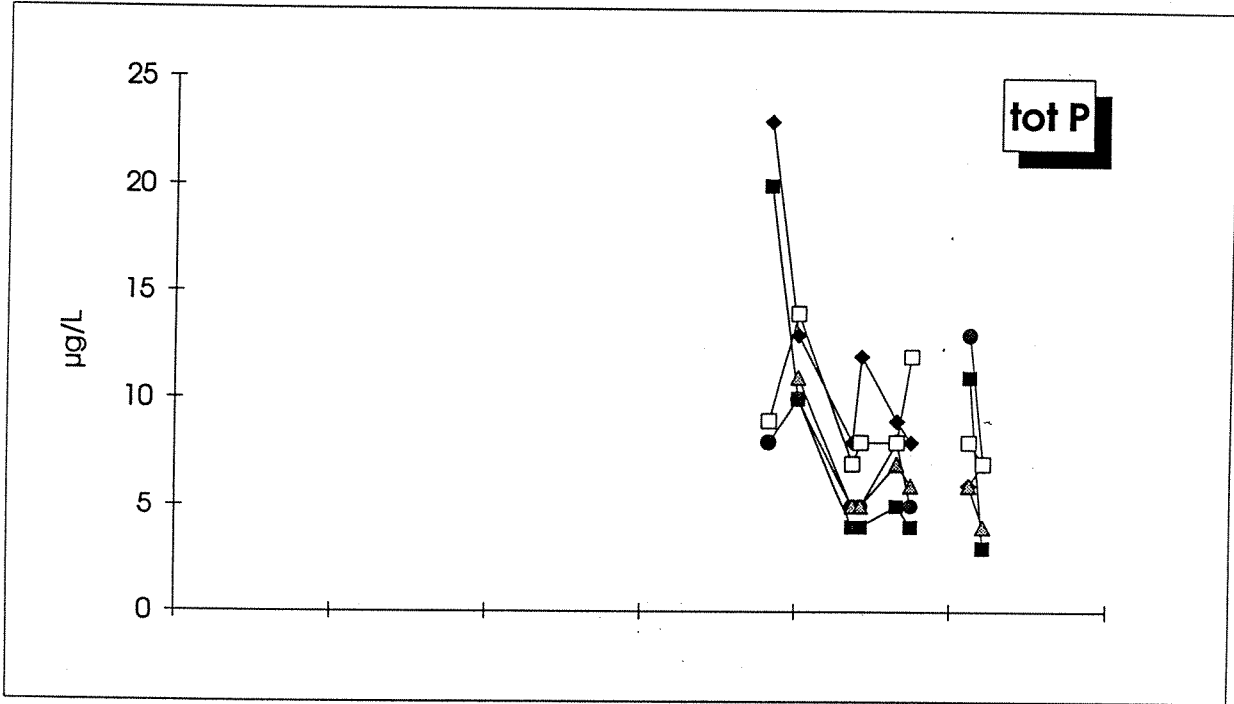
**Figure 4.6** Concentrations of nitrate (top panel), ammonium (middle panel), and organic N (lower panel) in runoff at 5 catchments at Risdalsheia December 1992 - December 1993.



**Figure 4.7** Concentrations of acid neutralizing capacity (ANC)(top panel),  $H^+$  (middle panel), and inorganic Al species ( $Al^{n+}$ ) (lower panel) in runoff at 5 catchments at Risdalsheia December 1992 - December 1993.



**Figure 4.8** Concentrations of total organic carbon (TOC) (top panel) and organic anions (A<sup>-</sup>) (lower panel) in runoff at 5 catchments at Risdalsheia December 1992 - December 1993.



**Figure 4.9** Concentrations of total P (top panel) and silica (lower panel) in runoff at 5 catchments at Risdalsheia December 1992 - December 1993.

## *Reference Catchments*

Beginning in May 1993 there are 3 untreated reference catchments in operation at Risdalsheia. These provide a measure of the natural catchment-to-catchment variation in runoff chemistry against which the changes induced by the treatments can be evaluated. During the first 6 months of operation these 3 catchments behaved similarly. The major difference among the catchments appears to be related to inherent differences in TOC concentrations in runoff (Figure 4.8). The difference in TOC levels influences the relative role of organic anions in runoff chemistry. There is no ready explanation for the difference in TOC levels between these catchments, as it is apparently not related to catchment size or soil depth.

For most of the other major ions the three reference catchments are quite similar. The concentration-time curves for these three catchments cross and overlap frequently (Figures 4.5-4.9). In most cases runoff from the roofed acid-rain catchment EGIL also falls close to the levels at the three control (no roof, acid rain) catchments. It would thus appear that with respect to runoff chemistry there is little or no roof effect.

## **4. Acknowledgements**

I thank R. Høgberget, A.-S. Indrøy, M. Lie and T. Sørvalg for careful and conscientious assistance in site operation, sampling and data handling.

## **5. References**

- Wright, R.F., Lotse, E., and Semb, A. 1988. Reversibility of acidification shown by whole-catchment experiments. *Nature* 334: 670-675.
- Wright, R.F., Lotse, E., and Semb, A. 1993. RAIN project: results after 8 years of experimentally reduced acid deposition to a whole catchment. *Can. J. Fish. Aquat. Sci.* 50: 258-268.

**APPENDIX: Pre-treatment Input- Output Budgets for CLIMEX sites.**

**A. Input-output budget for KIM catchment (roof, clean rain) for the winter 1993 (12 December 1992 - 14 May 1993).** Flux (columns 2 and 3) and concentrations (columns 3 and 4) in units  $\text{meq m}^{-2} \text{yr}^{-1}$  and  $\mu\text{eq l}^{-1}$ . (*mar.* = *marine*, *Dry part.* = *dry particulate deposition*, *c.d.* = *charge density*, *RAL* = *reactive Al*, *ILAL* = *organic Al*.)

	Input					Total	Output	In		Out	
	Wet	Dry						Wet	Total		
	mar.	part.	gases	subtot.							
H2O	264					264	218	H2O			
H+	0	0	0	0	0	0	12	H+	0	0	56
Na	12	11	0	0	11	23	22	Na	47	88	101
K	0	0	0	0	0	0	1	K	1	2	4
Ca	1	0	0	0	0	1	2	Ca	2	4	11
Mg	3	2	0	0	2	5	4	Mg	11	20	19
Al	0	0	0	0	0	0	1	Al	0	0	7
NH4	0	0	0	0	0	0	1	NH4	0	0	3
NO3	0	0	0	0	0	0	1	NO3	0	0	7
Cl	14	13	0	0	13	27	27	Cl	55	103	125
SO4	1	1	0	0	1	3	8	SO4	6	11	35
A-	0	0	0	0	0	0	7	A-	0	1	33
sum+	16	14	0	0	14	30	43	sum+	61	114	199
sum-	16	14	0	0	14	30	43	sum-	61	114	199
SBC	16	14	0	0	14	30	30	SBC	61	114	137
SSA	16	14	0	0	14	30	36	SSA	60	113	166
alk	0	0	0	0	0	0	-6	alk	0	1	-29
TOC							2.4	TOC	mgC/l		11.1
SiO2							0.5	SiO2	mgSiO2/l		2.4
c.d.							3.0	c.d.			3.0
RAL							59	RAL	$\mu\text{gAl/l}$		273
ILAL							45	ILAL	$\mu\text{gAl/l}$		207
TOTN							108	TOTN	$\mu\text{gN/l}$		497

**B. Input-output budget for KIM catchment (roof, clean rain) for summer 1993 (15 May 1993 - 2 December 1993).**

	Input					Total	Output	In			Out	
	Wet	Dry						Wet	Total			
	mar.	part.	gases	subtot.								
H2O	376					376	200	H2O				
H+	0	0	1	19	20	20	13	H+	0	53	67	
Na	24	-7	0	0	-7	17	18	Na	63	45	90	
K	1	0	0	0	0	0	0	K	1	1	2	
Ca	1	0	0	0	0	1	2	Ca	3	2	10	
Mg	5	-2	0	0	-2	4	3	Mg	14	10	17	
Al	0	0	0	0	0	0	1	Al	0	0	4	
NH4	0	0	4	0	4	4	0	NH4	0	11	1	
NO3	0	0	0	11	11	11	1	NO3	0	29	3	
Cl	28	-8	0	0	-8	20	20	Cl	73	52	98	
SO4	3	-1	5	8	12	15	7	SO4	8	40	36	
A-	0	0	0	0	0	0	11	A-	1	-0	54	
sum+	31	-9	5	19	15	46	38	sum+	81	122	191	
sum-	31	-9	5	19	15	46	38	sum-	81	122	191	
SBC	31	-9	4	0	-5	26	24	SBC	81	69	121	
SSA	30	-9	5	19	15	46	27	SSA	81	121	137	
alk	0	0	-1	-19	-20	-20	-3	alk	1	-53	-17	
TOC							3.5	TOC	mgC/l		17.3	
SiO2							0.5	SiO2	mgSiO2/l		2.5	
c.d.							3.1	c.d.			3.1	
RAL							61	RAL	µgAl/l		304	
ILAL							54	ILAL	µgAl/l		268	
TOTN							88	TOTN	µgN/l		441	

**C. Input-output budget for KIM catchment (roof, clean rain) for the year (12 December 1992 - 2 December 1993).**

	Input					Total	Output	In		Out
	Wet	Dry						Wet	Total	
	mar.	part.	gases	subtot.						
H2O	640				640	418	H2O	640	640	640
H+	0	0	1	19	20	20	H+	0	31	61
Na	36	4	0	0	4	40	Na	56	63	95
K	1	0	0	0	0	1	K	1	1	3
Ca	2	0	0	0	0	2	Ca	2	3	11
Mg	8	1	0	0	1	9	Mg	13	14	18
Al	0	0	0	0	0	0	Al	0	0	5
NH4	0	0	4	0	4	4	NH4	0	6	2
NO3	0	0	0	11	11	11	NO3	0	17	5
Cl	42	5	0	0	5	47	Cl	66	73	112
SO4	4	0	5	8	13	18	SO4	7	28	36
A-	0	0	0	0	0	0	A-	0	0	43
sum+	47	5	5	19	29	76	sum+	73	118	195
sum-	47	5	5	19	29	76	sum-	73	118	195
SBC	47	5	4	0	9	56	SBC	73	87	129
SSA	46	5	5	19	29	76	SSA	72	118	152
alk	0	0	-1	-19	-20	-20	alk	0	-31	-23
TOC							5.9	TOC mgC/l		14.1
SiO2							1.0	SiO2 mgSiO2/l		2.5
c.d.							3.1	c.d.		3.1
RAL							120	RAL µgAl/l		288
ILAL							99	ILAL µgAl/l		236
TOTN							196	TOTN µgN/l		470



**D. Input-output budget for EGIL catchment (roof, acid rain) for winter 1993 (12 December 1992 - 14 May 1993).**

	Input					Total	Output		In	Out
	Wet	Dry					Wet	Total		
	mar.	part.	gases	subtot.						
H2O	292				292	254	H2O			
H+	16	0	0	0	16	23	H+	56	56	91
Na	34	9	0	0	43	41	Na	116	147	160
K	1	0	0	0	1	1	K	4	5	4
Ca	2	0	0	0	2	3	Ca	8	9	20
Mg	8	2	0	0	10	8	Mg	26	33	32
Al	0	0	0	0	0	4	Al	0	0	14
NH4	9	0	0	0	9	2	NH4	33	33	6
NO3	12	0	0	0	12	8	NO3	41	41	33
Cl	40	11	0	0	51	51	Cl	138	174	199
SO4	21	1	0	0	22	25	SO4	72	76	100
A-	-2	0	0	0	-2	-1	A-	-8	-8	-5
sum+	71	12	0	0	83	83	sum+	243	283	327
sum-	71	12	0	0	83	83	sum-	243	283	327
SBC	55	12	0	0	66	56	SBC	187	227	222
SSA	73	12	0	0	85	84	SSA	251	291	332
alk	-19	0	0	0	-19	-28	alk	-64	-64	-110
TOC						1.3	TOC	mgC/l		5.0
SiO2						0.9	SiO2	mgSiO2/l		3.5
c.d.						-0.9	c.d.			-0.9
RAL						67	RAL	µgAl/l		262
ILAL						30	ILAL	µgAl/l		118
TOTN						167	TOTN	µgN/l		658

**E. Input-output budget for EGIL catchment (roof, acid rain) for summer 1993 (15 May 1993 - 2 December 1993).**

	Input					Total	Output		In	Out	
	Wet	Dry					Wet	Total			
	mar.	part.	gases	subtot.							
H2O	399				399	315	H2O				
H+	17	0	0	1	19	30	H+	43	91	94	
Na	21	10	0	0	0	21	35	Na	53	53	112
K	2	0	0	0	0	2	1	K	4	4	4
Ca	3	0	0	0	0	3	5	Ca	8	8	17
Mg	5	2	0	0	0	5	8	Mg	13	13	26
Al	0	0	0	0	0	0	5	Al	0	0	17
NH4	11	0	0	4	0	11	2	NH4	26	26	8
NO3	13	0	0	0	11	24	9	NO3	31	59	30
Cl	24	11	0	0	0	24	36	Cl	61	61	113
SO4	24	1	0	5	8	32	39	SO4	60	80	124
A-	-2	0	0	0	0	-2	3	A-	-5	-5	10
sum+	59	13	0	5	19	78	87	sum+	147	195	277
sum-	59	13	0	5	19	78	87	sum-	147	195	277
SBC	41	13	0	4	0	41	52	SBC	104	104	166
SSA	61	13	0	5	19	80	84	SSA	152	200	267
alk	-19	0	0	-1	-19	-38	-32	alk	-48	-96	-101
TOC							2.8	TOC	mgC/l		8.9
SiO2							1.1	SiO2	mgSiO2/l		3.4
c.d.							1.1	c.d.			1.1
RAL							121	RAL	µgAl/l		384
ILAL							69	ILAL	µgAl/l		217
TOTN							281	TOTN	µgN/l		893

**F. Input-output budget for EGIL catchment (roof, acid rain) for the year (12 December 1992 - 2 December 1993).**

	Input					Total	Output		In	Out
	Wet	Dry					Wet	Total		
	mar.	part.	gases	subtot.						
H2O	690				690	569	H2O	690	690	569
H+	34	0	0	1	19	53	H+	49	76	93
Na	55	19	0	0	9	64	76	Na	80	93
K	3	0	0	0	0	3	2	K	4	5
Ca	5	1	0	0	0	6	10	Ca	8	8
Mg	13	4	0	0	2	15	16	Mg	18	21
Al	0	0	0	0	0	0	9	Al	0	0
NH4	20	0	0	4	0	20	4	NH4	29	29
NO3	25	0	0	0	11	36	18	NO3	36	51
Cl	64	22	0	0	11	75	86	Cl	93	109
SO4	45	2	0	5	9	54	65	SO4	65	78
A-	-4	0	0	0	0	-4	2	A-	-6	-6
sum+	130	24	0	5	31	160	170	sum+	188	232
sum-	130	24	0	5	31	160	170	sum-	188	232
SBC	96	24	0	4	12	108	109	SBC	139	156
SSA	134	24	0	5	31	165	168	SSA	194	238
alk	-38	0	0	-1	-19	-57	-60	alk	-55	-82
TOC							4.1	TOC mgC/l		7.2
SiO2							2.0	SiO2 mgSiO2/l		3.4
c.d.							0.5	c.d.		0.5
RAL							188	RAL µgAl/l		330
ILAL							98	ILAL µgAl/l		173
TOTN							448	TOTN µgN/l		788

**G. Input-output budgets for ROLF catchment (no roof, acid rain) for winter 1993 (12 December 1992 - 14 May 1993).**

	Input					Total	Output	In		Out	
	Wet	Dry	gases					Wet	Total		
	mar.	part.	subtot.								
H2O	333					333	268	H2O			
H+	16	0	0	0	0	16	28	H+	49	49	104
Na	75	11	0	0	11	86	78	Na	224	258	290
K	3	0	0	0	0	3	5	K	8	9	18
Ca	6	0	0	0	0	6	8	Ca	17	18	28
Mg	16	3	0	0	3	19	17	Mg	49	56	64
Al	0	0	0	0	0	0	3	Al	0	0	11
NH4	23	0	0	0	0	23	8	NH4	70	70	31
NO3	22	0	0	0	0	22	12	NO3	67	67	45
Cl	89	13	0	0	13	103	103	Cl	268	308	383
SO4	32	1	0	0	1	34	33	SO4	97	101	123
A-	-5	0	0	0	0	-5	-1	A-	-15	-15	-3
sum+	139	15	0	0	15	154	147	sum+	417	462	547
sum-	139	15	0	0	15	154	147	sum-	417	462	547
SBC	123	15	0	0	15	137	116	SBC	368	412	432
SSA	144	15	0	0	15	159	148	SSA	432	476	550
alk	-21	0	0	0	0	-21	-32	alk	-64	-64	-118
TOC							1.5	TOC mgC/l			5.5
SiO2							0.3	SiO2 mgSiO2/l			1.1
c.d.							-0.6	c.d.			-0.6
RAL							60	RAL µgAl/l			224
ILAL							31	ILAL µgAl/l			115
TOTN							346	TOTN µgN/l			1288

H. Input-output budgets for ROLF catchment (no roof, acid rain) for summer 1993 (15 May 1993 - 2 December 1993).

	Input					Total	Output	In			Out
	Wet	Dry						Wet	Total		
	mar.	part.	gases	subtot.							
H2O	583				583	472	H2O				
H+	28	0	1	19	20	48	42	H+	48	82	89
Na	29	19	0	0	19	48	83	Na	49	83	177
K	3	0	0	0	0	3	3	K	5	5	6
Ca	5	1	0	0	1	6	9	Ca	8	10	19
Mg	7	4	0	0	4	12	15	Mg	12	20	32
Al	0	0	0	0	0	0	3	Al	0	0	7
NH4	18	0	4	0	4	22	6	NH4	31	38	13
NO3	20	0	0	11	11	31	9	NO3	34	53	20
Cl	33	23	0	0	23	56	56	Cl	57	96	118
SO4	39	2	5	8	15	54	65	SO4	66	92	138
A-	-2	0	0	0	0	-2	32	A-	-4	-4	68
sum+	89	25	5	19	49	138	162	sum+	153	237	343
sum-	89	25	5	19	49	138	162	sum-	153	237	343
SBC	61	25	4	0	29	90	116	SBC	105	155	247
SSA	91	25	5	19	49	140	130	SSA	157	241	276
alk	-30	0	-1	-19	-20	-50	-14	alk	-52	-86	-29
TOC							8.1	TOC	mgC/l		17.1
SiO2							1.6	SiO2	mgSiO2/l		3.4
c.d.							3.9	c.d.			3.9
RAL							157	RAL	µgAl/l		332
ILAL							123	ILAL	µgAl/l		260
TOTN							438	TOTN	µgN/l		927

**I. Input-output budget for ROLF catchment (no roof, acid rain) for the year (12 December 1992 - 2 December 1993).**

	Input					Total	Output	In			Out
	Wet	Dry						Wet	Total		
	mar.	part.	gases	subtot.							
H2O	917				917	741	H2O	917	917	741	
H+	44	0	1	19	20	64	70	H+	48	70	95
Na	103	31	0	0	31	134	161	Na	113	146	218
K	6	1	0	0	1	6	8	K	6	7	11
Ca	10	1	0	0	1	12	16	Ca	11	13	22
Mg	23	7	0	0	7	30	33	Mg	25	33	44
Al	0	0	0	0	0	0	6	Al	0	0	8
NH4	41	0	4	0	4	45	14	NH4	45	49	19
NO3	42	0	0	11	11	53	21	NO3	46	58	29
Cl	122	36	0	0	36	158	158	Cl	134	173	214
SO4	71	4	5	8	17	88	98	SO4	77	95	132
A-	-7	0	0	0	0	-7	31	A-	-8	-8	42
sum+	228	40	5	19	64	292	309	sum+	249	319	417
sum-	228	40	5	19	64	292	309	sum-	249	319	417
SBC	184	40	4	0	44	228	232	SBC	201	249	314
SSA	235	40	5	19	64	299	278	SSA	257	326	375
alk	-52	0	-1	-19	-20	-71	-45	alk	-56	-78	-61
TOC							9.6	TOC	mgC/l		12.9
SiO2							1.9	SiO2	mgSiO2/l		2.6
c.d.							3.2	c.d.			3.2
RAL							217	RAL	µgAl/l		293
ILAL							154	ILAL	µgAl/l		208
TOTN							783	TOTN	µgN/l		1058

**J. Input-output budget for METTE catchment (no roof, acid rain) for summer 1993 (15 May 1993 - 2 December 1993).**

	Input					Total	Output	In			Out	
	Wet	Dry						Wet	Total			
	mar.	part.	gases	subtot.								
H2O	553					553	416	H2O				
H+	27	0	1	19	20	47	37	H+	48	84	89	
Na	27	16	0	0	16	43	60	Na	49	77	144	
K	2	0	0	0	0	3	4	K	4	5	8	
Ca	4	1	0	0	1	5	7	Ca	7	8	16	
Mg	6	4	0	0	4	10	10	Mg	11	18	25	
Al	0	0	0	0	0	0	5	Al	0	0	13	
NH4	16	0	4	0	4	20	3	NH4	30	37	7	
NO3	19	0	0	11	11	30	9	NO3	34	54	22	
Cl	31	18	0	0	18	49	49	Cl	57	90	119	
SO4	36	2	5	8	15	51	46	SO4	65	92	112	
A-	-4	0	0	0	0	-4	21	A-	-6	-6	51	
sum+	82	20	5	19	44	127	126	sum+	149	229	303	
sum-	82	20	5	19	44	127	126	sum-	149	229	303	
SBC	56	20	4	0	24	80	84	SBC	101	145	201	
SSA	86	20	5	19	44	130	105	SSA	156	236	252	
alk	-30	0	-1	-19	-20	-50	-21	alk	-55	-91	-51	
TOC							6.9	TOC	mgC/l		16.7	
SiO2							1.3	SiO2	mgSiO2/l		3.2	
c.d.							3.0	c.d.			3.0	
RAL							178	RAL	µgAl/l		427	
ILAL							123	ILAL	µgAl/l		296	
TOTN							366	TOTN	µgN/l		880	

**K. Input-output budget for CECILIE catchment (no roof, acid rain) for summer 1993  
(15 May 1993 - 2 December 1993).**

	Input					Total	Output		In	Out	
	Wet	Dry					Wet	Total			
	mar.	part.	gases	subtot.							
H2O	553				553	416	H2O				
H+	27	0	1	19	20	42	H+	48	84	100	
Na	27	17	0	0	17	44	59	Na	49	80	141
K	2	0	0	0	0	3	2	K	4	5	6
Ca	4	1	0	0	1	5	9	Ca	7	8	21
Mg	6	4	0	0	4	10	11	Mg	11	18	27
Al	0	0	0	0	0	0	7	Al	0	0	17
NH4	16	0	4	0	4	20	2	NH4	30	37	5
NO3	19	0	0	11	11	30	11	NO3	34	54	25
Cl	31	20	0	0	20	51	51	Cl	57	93	123
SO4	36	2	5	8	15	51	51	SO4	65	93	122
A-	-4	0	0	0	0	-4	19	A-	-6	-6	46
sum+	82	22	5	19	46	128	132	sum+	149	233	317
sum-	82	22	5	19	46	128	132	sum-	149	233	317
SBC	56	22	4	0	26	82	83	SBC	101	148	200
SSA	86	22	5	19	46	132	113	SSA	156	239	271
alk	-30	0	-1	-19	-20	-50	-30	alk	-55	-91	-71
TOC							5.3	TOC	mgC/l		12.7
SiO2							1.1	SiO2	mgSiO2/l		2.8
c.d.							3.6	c.d.			3.6
RAL							169	RAL	µgAl/l		406
ILAL							97	ILAL	µgAl/l		232
TOTN							411	TOTN	µgN/l		989



# Chapter 5

## *Soil Chemistry and Decomposition of Organic Matter*

---

P.S.J. Verburg and N. van Breemen

Department of Soil Science & Geology  
Wageningen Agricultural University  
PO Box 37  
6700 AA Wageningen  
The Netherlands

### Summary

Litterbag studies and N mineralization measurements show that decomposition rates of soil organic matter vary between as well as within catchments. The decomposition rate of pine litter appears to be enhanced under the roofs. The main variable explaining the difference is likely to be temperature and/or actual evapotranspiration. N mineralization measurements show that the control and treatment section in both KIM and EGIL are different before the start of the treatment. This is likely due to a combination of differences in soil depth, soil temperature and soil moisture. Patterns found in the runoff chemistry are also found in soil solution. Seasonal variation in soil solution chemistry is linked to root activity.

### 1. Introduction

Globally, some 50-100 Gt of C per year is cycled along the photosynthesis-decomposition pathway against an annual net addition of CO<sub>2</sub>-C to the atmosphere of 2.8 Gt (Goudriaan 1992). Therefore, changes in decomposition rate of soil organic matter (SOM) due to climate change might significantly influence the net exchange of CO<sub>2</sub> between the atmosphere and the land surface. Both increases in temperature and increases in CO<sub>2</sub> could affect decomposition of SOM.

An increase in temperature could affect decomposition in two ways:

- 1) Biological activity may be stimulated, thus *increasing* decomposition (Swift et al., 1979).
- 2) Evapotranspiration of water from the soil may be enhanced. If initially wet soils become drier, increased availability of oxygen may stimulate biological activity and *increase* decomposition. In soils which are already relatively dry, moisture content can become limiting for biological activity, thereby *decreasing* decomposition.

An increase in atmospheric CO<sub>2</sub> could affect decomposition in three ways (Van Breemen and Van Dam 1993):

1) Net Primary Production (NPP), especially of C<sub>3</sub> plants, may increase (Mooney et al. 1991). Increased NPP would lead to increased production of litter. As a result, the pool of easily-decomposable material would increase. The effect of CO<sub>2</sub> on the chemical composition of litter is still being debated. It is, however, likely that if CO<sub>2</sub> influences the chemical composition of litter, decomposition rates will also be influenced (Couteaux et al. 1992).

2) Water use efficiency (WUE) (ratio fixed C/transpired water) may increase, causing transpiration of vegetation (per unit of biomass) to decrease. In the absence of other influences, soils would become wetter. Since, however, an increase in NPP creates a larger amount of transpiring biomass, and since higher temperatures promote evapotranspiration of water from the soil and plants, soils would only get wetter if the increase in WUE is larger than the increase in fixed C and evaporation.

3) Gas diffusion would cause an increase in soil CO<sub>2</sub> concentration mainly because of increased C allocation to the roots. This would then lower soil pH in non-acid soils. Conditions for biological activity might become less favourable.

In most temperate regions an increase in temperature will favour decomposition of SOM (releasing C) whereas an increase in atmospheric CO<sub>2</sub> will favour litter production (fixing C). The sum of the two opposing fluxes will determine whether changes in the pool size of SOM will occur. In any case, turnover times (pool size/sum of input and removal rates) of the SOM pool will decrease, making the system less stable.

In many temperate ecosystems plant growth is limited by the availability of N. Increased decomposition could favour plant growth by increased N-mineralization. Non-limiting nutrients are likely to leach in drainage water and might cause eutrophication and acidification of surface waters.

The different hypotheses discussed above will be tested in this part of CLIMEX using field and complementary laboratory studies. The planned experiments and the results of the first year of collection of base line data are presented below.

## **2. Methods**

### *Field Studies*

#### *Litterbag experiments*

The majority of the nutrients that are readily available for plant growth are released by decomposition of fresh litter. The decomposition rate of humified material is usually one to three orders of magnitude lower and does not play a large role in supplying nutrients. Therefore, if plant growth is limited by N, a change in the decomposition rate of fresh litter is likely to have a direct effect on plant growth.

Using litterbags we investigate the influence of temperature and substrate quality on the decomposition rate of fresh litter under field conditions. In 1993, young *Betula* (birch) trees were grown in the lab under either ambient CO<sub>2</sub> or 700 ppmv CO<sub>2</sub>. The litter produced by

these trees (the same as used in the soil fauna experiments, Chapter 9) was collected and analyzed for C, N and lignin. C and N were determined by element analyzer and lignin was determined as weight loss of leaf residue upon ignition at 650 °C after dissolution in 80% alcohol at 76°C, 72% sulphuric acid at 30°C and 3% sulphuric acid at 80°C. The "high CO<sub>2</sub>" litter had an average C/N ratio of 88 whereas the C/N ratio of the "low CO<sub>2</sub>" litter was 67 (Table 9.2 of Chapter 9). The lignin content was 157 and 164 mg/g dry matter for the high and low CO<sub>2</sub> litter, respectively.

Beginning in April 1994, both "high CO<sub>2</sub>" and "low CO<sub>2</sub>" litter is being incubated in the manipulated and unmanipulated parts of KIM and EGIL. This experimental design allows for separation of the temperature effect from the substrate quality effect. For each litter type ten replicates are used. Mesh size of the litterbags is 1.5 mm. The litterbags will be incubated for 2 years. Samples will be taken at t = 0, 0.5, 1 and 2 years and analyzed for C, N and lignin. The same litterbags will be used throughout for the soil fauna experiment (Chapter 9).

A pilot study with litter from *Pinus sylvestris* suggested that decomposition was significantly faster in the two roofed catchments KIM and EGIL than in the open catchment ROLF (Table 5.1). This may be a temperature effect: annual average soil temperature in the enclosed catchments is approximately 1.5°C higher than in the reference catchment (Figure 2.14 of Chapter 2). No differences in decomposition rate were found between litter incubated under *Vaccinium* or *Calluna*.

**Table 5.1** Mass loss of pine litter after 1 year under different dwarf shrubs. Standard deviation in parentheses, different letters indicate significant differences at the 0.0005 level of significance.

Location		Mass Loss (%)		N
KIM	<i>Calluna</i>	30.7 (5.3)	a	25
	<i>Vaccinium</i>	28.5 (5.0)	a	24
EGIL	<i>Calluna</i>	25.0 (3.9)	b	25
ROLF	<i>Calluna</i>	22.2 (4.3)	c	25
	<i>Vaccinium</i>	22.0 (6.1)	b, c	25

A litterbag experiment is currently being carried out to examine whether differences in decomposition rate occur between the control and treatment sections within the roofed catchments.

#### *N-mineralization measurements by field incubations*

Depending on the C/N ratio of the substrate, increased decomposition might result in increased mineralization of N. We are measuring N-mineralization by incubating undisturbed field-moist soil cores (method of Raison et al. 1987) in plots dominated by either *Calluna* or *Vaccinium* in both treatment and control sections of KIM and EGIL as well as in the reference catchment METTE. In the same five vegetation plots as used for the dwarf shrub measurements (Chapter 6), two subplots were selected. During each incubation period, one sample is incubated in each subplot resulting in ten replicates for each measurement. In 1993 "background" N-mineralization was measured. The measurements were made over four periods: April-June, June-August, August-October and October-April. The amount of N occurring as NO<sub>3</sub><sup>-</sup> equals nitrification.

In all sections a clear seasonal trend is observed (Figure 5.1), with no significant differences in mineralization rate between *Calluna* and *Vaccinium*. The anomalously high mineralization rate observed in *Vaccinium* in the control section of KIM between December and April is due to two high values out of ten that are most likely analysis errors.

Because of the many factors that may differ among catchments (e.g., light, soil moisture, temperature) meaningful comparisons with respect to N-mineralization are premature. Within catchments, there is significantly higher total N mineralization in the treatment section of EGIL than in the control section, and, for *Vaccinium*, somewhat higher mineralization in the treatment section of KIM than in the control. N-mineralization under *Calluna* in KIM shows the reverse trend: it is slightly higher in the control section than the treatment section. No simple explanation for this can yet be given since many parameters determining the mineralization rate have strong interactions. In EGIL the average soil depth of the control section is lower than in the treatment section (Figure 2.3 of Chapter 2). Therefore the water storage capacity is lower, resulting in lower soil moisture levels in dry periods. Differences in soil moisture between sections will also cause differences in temperature. To investigate these interactions and their combined effect on N-mineralization, further analysis of the data will be carried out using multiple regression models.

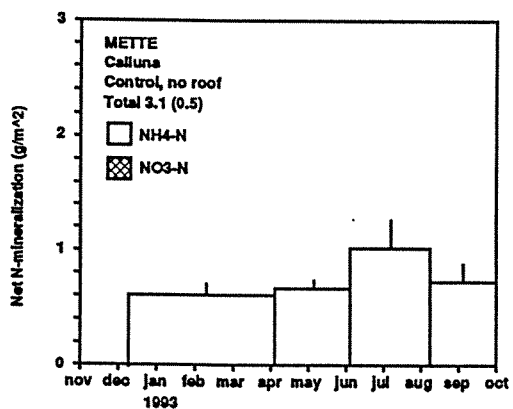
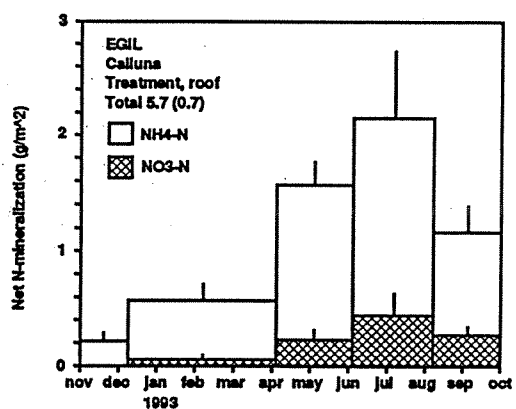
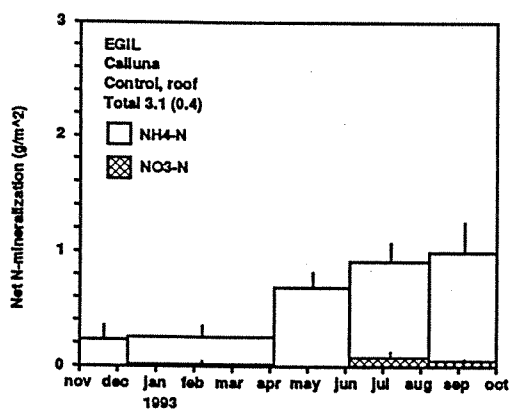
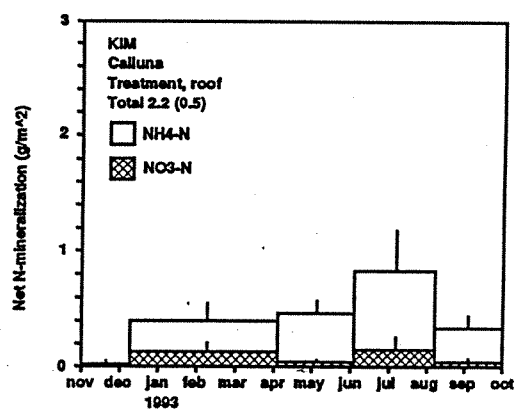
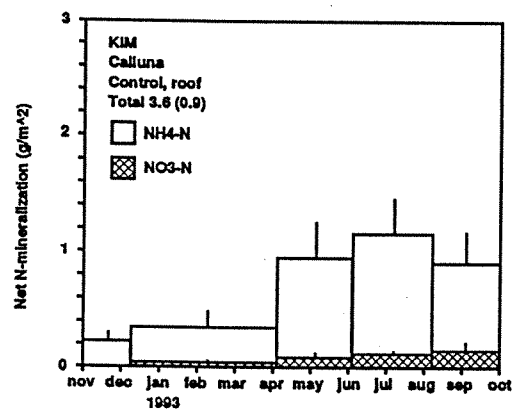
### *Soil solution*

Increased decomposition due to the CLIMEX treatment is expected to cause more nutrients to come into solution and become available for plant growth. Outflow of nutrients that are not limiting for plant growth could increase. Export fluxes of limiting nutrients like N are not expected to increase since most of the mineralized N will be taken up by the vegetation.

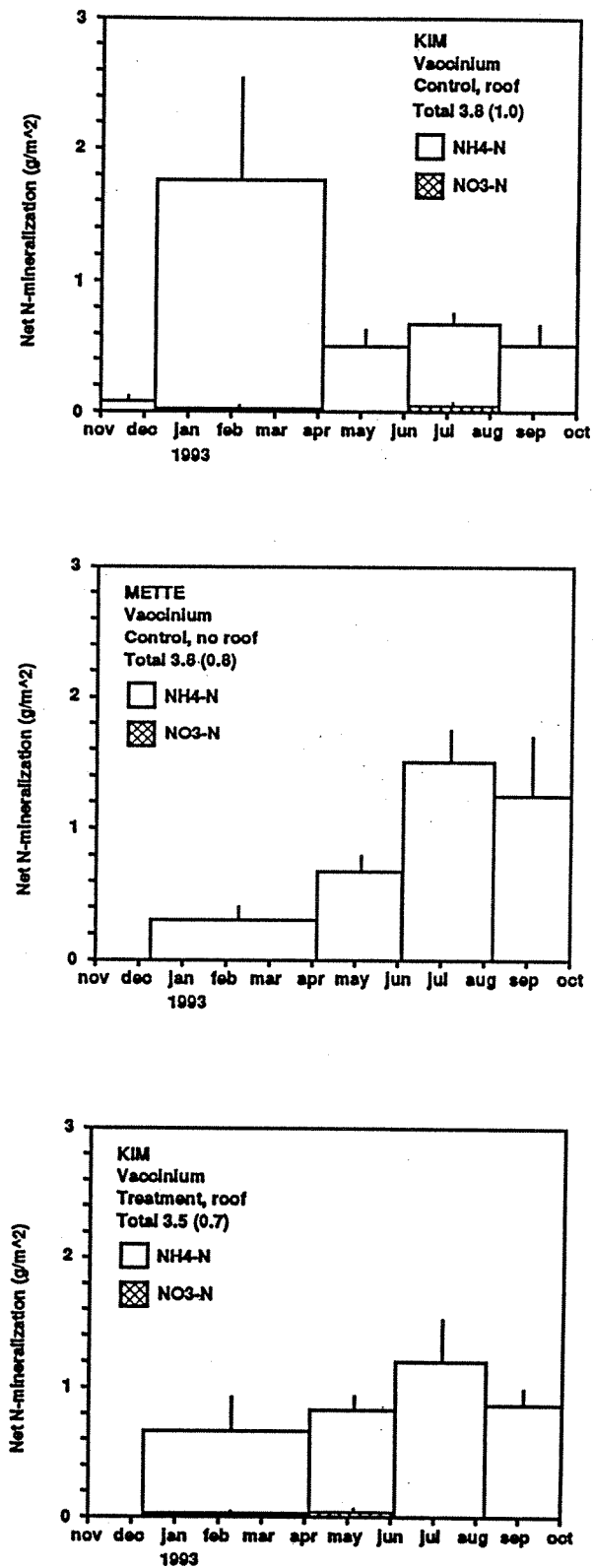
Changes in runoff chemistry have occurred over the past 9 years as a result of the treatments in the RAIN project (Chapter 4). It is therefore likely that differences in soil solution chemistry are present between the catchments. Monitoring of soil solution chemistry was started in the autumn of 1992 to provide the necessary background data. Lysimeters were installed at three depths in all manipulated and unmanipulated sections of the enclosures as well as in the reference catchment. Bimonthly samples are taken and analyzed for all major organic and inorganic components.

Depth-averaged concentrations of major ions in soil solution (Table 5.2) indicate that alkalinity is generally highest in KIM, reflecting the absence of strong acid anions. Soil solution TOC is lower in April than in October. In April, more N was present in the soil solution, possibly associated with reduced uptake of N by roots. Both Al and SiO<sub>2</sub> increase with depth, reflecting the presence of more mineral material in the deeper soil layers.

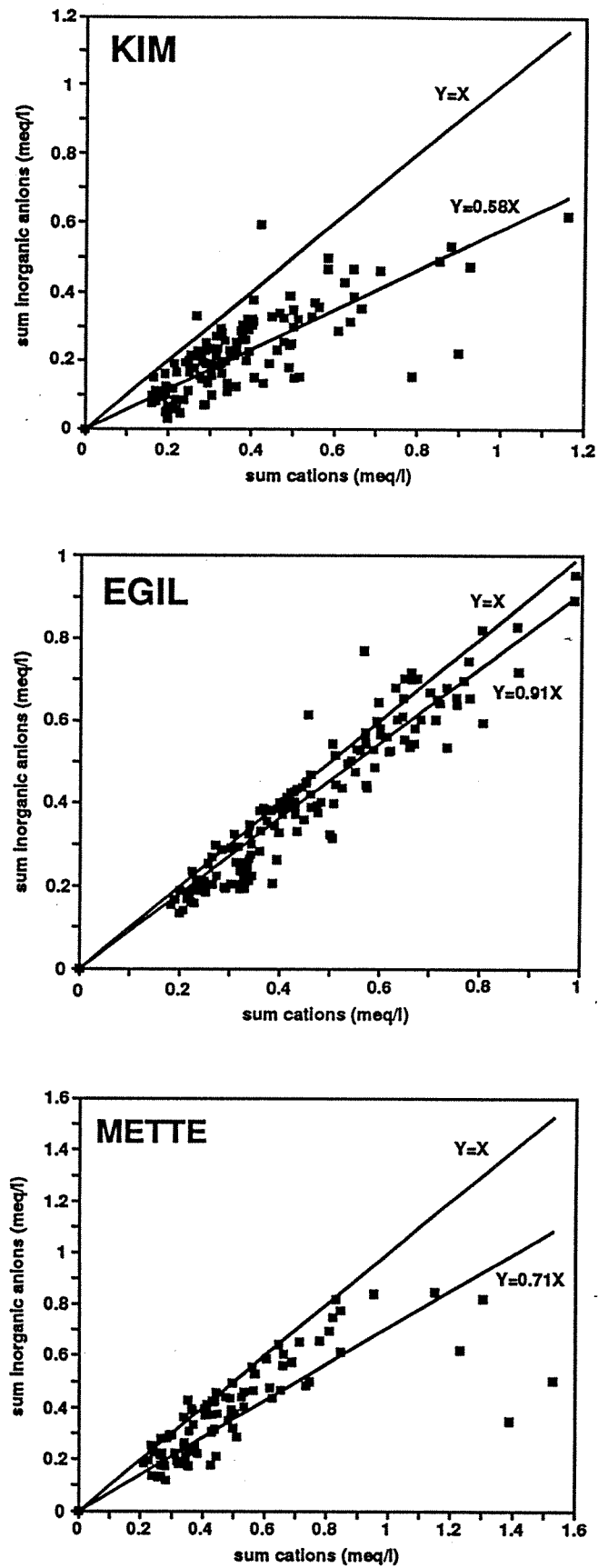
The contribution of organic anions to the charge balance has proven to be very sensitive to the acid/clean rain treatment (Figure 5.2). In the acid rain treatment (EGIL/METTE) less positive charge is neutralized by organic anions than in the clean rain treatment (KIM). In the clean rain treatment the decrease in strong acid anions has been compensated by organic anions. These findings correspond closely with the runoff data collected during the RAIN experiment (Figure 4.4). Further analysis of the data and flux calculations will be carried out in combination with soil moisture data.



**Figure 5.1a** Net N mineralization in vegetation plots dominated by *Calluna vulgaris*. Total yearly N mineralization is given with the standard error in parentheses. The bars in the graph represent the standard error (n=10).



**Figure 5.1b** Net N mineralization in vegetation plots dominated by *Vaccinium myrtillus*. Total yearly N mineralization is given with the standard error in parentheses. The bars in the graph represent the standard error (n=10).



**Figure 5.2** Contribution of organic anions to charge balance for all soil solution samples. The  $R^2$  of the regression line for the samples from KIM, EGIL and METTE is 0.55, 0.89 and 0.53 respectively.

**Table 5.2** Average soil solution chemistry for three depths in each catchment. Results are shown for April and October.

Location	pH	µmol/l											Alk. <sup>1</sup>	Charge balance <sup>2</sup>				
		TOC	SiO <sub>2</sub>	H	K	Na	Ca	Mg	Al	Fe	NH <sub>4</sub>	Cl			NO <sub>3</sub>	SO <sub>4</sub>	Tot <sup>+</sup>	Tot <sup>-</sup>
<i>April 1993</i>																		
EGIL 5-10	3.88	652	11	132	8	281	25	59	57	5	27	475	27	119	594	622	-281	-5
EGIL 15-20	4.00	470	22	104	3	277	14	47	175	8	2	507	20	102	630	628	-332	0
EGIL 25-35	4.18	427	35	69	6	240	15	40	180	24	6	450	14	72	580	535	-269	8
KIM 5-10	3.90	2188	10	134	15	116	31	40	26	12	19	136	9	54	393	199	-17	49
KIM 15-20	4.08	1036	15	86	12	136	14	34	44	28	3	219	8	64	356	291	-126	18
KIM 25-35	4.67	613	21	26	6	120	8	21	57	63	4	229	0	36	305	265	-127	13
METTE 5-10	3.73	1440	4	216	32	214	30	38	8	5	27	323	33	105	569	460	-158	19
METTE 15-20	3.89	864	5	146	25	193	15	39	23	12	18	295	46	118	471	458	-208	3
METTE 25-35	4.16	527	17	75	12	164	14	36	73	11	5	240	28	109	391	377	-181	4
<i>October 1993</i>																		
EGIL 5-10	3.96	2291	46	113	4	134	13	27	71	13	7	192	5	104	382	300	-142	21
EGIL 15-20	4.06	1167	73	92	4	151	8	25	138	5	4	187	1	133	428	320	-153	25
EGIL 25-35	4.35	787	87	47	6	181	14	40	202	5	0	190	11	211	495	412	-210	17
KIM 5-10	3.69	6931	33	232	9	140	33	47	30	11	1	129	3	36	502	168	15	67
KIM 15-20	4.00	2388	62	106	4	127	10	29	106	14	0	153	0	36	396	189	-48	52
KIM 25-35	4.39	880	74	41	4	107	11	30	99	9	0	145	0	59	301	204	-82	32
METTE 5-10	3.92	6077	56	120	37	529	112	47	10	17	6	197	6	169	877	372	311	58
METTE 15-20	3.83	3067	58	162	16	173	14	34	89	24	1	164	3	119	513	286	-82	44
METTE 25-35	4.21	1222	105	66	5	144	12	33	132	21	0	170	0	136	414	305	-144	26

<sup>1</sup> Alkalinity is calculated as sum of base cations - sum strong acid anions

<sup>2</sup> percentage of positive charge balanced by organic anions ( $= 100 * (\text{Tot}^+ - \text{Tot}^-) / \text{Tot}^+$ )



### *Isotope studies on a catchment scale*

Fresh litter contains relatively large amounts of easily decomposable materials with a short turnover time. Upon decomposition, the substrate is enriched in resistant compounds like lignin which cause turnover times to increase. Balesdent et al. (1987) used the difference in natural abundance of  $^{13}\text{C}$  between  $\text{C}_3$  and  $\text{C}_4$  plants to calculate turnover times of SOM in soils after a shift in vegetation from  $\text{C}_3$  to  $\text{C}_4$  plants. Veldkamp (1993) successfully used the same method in a deforestation study where primary forest ( $\text{C}_3$ ) was being replaced by maize ( $\text{C}_4$ ). If the vegetation does not change from  $\text{C}_3$  to  $\text{C}_4$  or vice versa, addition of  $\text{CO}_2$  differing in isotopic composition from natural  $\text{CO}_2$  can cause a change in isotopic composition of newly produced plant litter. Leavitt et al. (in press) have conducted free-air  $\text{CO}_2$  enrichment (FACE) experiments with  $\text{CO}_2$  depleted in  $^{13}\text{C}$ . They found that within three years 10% of the SOM was derived from newly-produced plant material.

We will use the isotope signal from  $\text{CO}_2$  depleted in  $^{13}\text{C}$  that will be added in the high  $\text{CO}_2$  treatments to trace the fate of high- $\text{CO}_2$ -grown plant litter in the soil. In October 1993 soil samples were taken in all catchments in the different plots to give baseline values for  $^{13}\text{C}$  content. The same samples are being used for the root research part of CLIMEX (Chapter 6).

### *Laboratory Studies*

#### *C budget for soil columns*

The release of  $\text{CO}_2$  by decomposition can be regarded as a positive feedback mechanism to climate change. In the field, the contribution to  $\text{CO}_2$  emissions from decomposition is difficult to estimate due to interference of  $\text{CO}_2$  released by root respiration (10 to 40% of efflux of  $\text{CO}_2$  from the soil).  $\text{CO}_2$  produced by decomposition alone can be estimated by using soil columns without vegetation. Undisturbed soil columns taken from outside the catchments under *Calluna* vegetation are incubated at 5, 10 and 15°C in the lab to examine the effect of temperature on C mineralization. Five replicates are used at each temperature treatment. Cumulative  $\text{CO}_2$  emission is measured continuously by capturing  $\text{CO}_2$  with soda lime. Soil solution chemistry and moisture level are monitored at three depths on a weekly basis. DOC fractionation according to Leenheer (1979) is performed monthly on samples from both lysimeters and leachate.

#### *C-mineralization of different SOM fractions*

An increase in temperature is expected to stimulate decomposition of "old" SOM. Not all SOM will, however, be decomposed more rapidly at increased temperature. Some humified organic matter is protected against microbial attack by complexation with mineral particles. In addition, in deeper soil layers, soil physical conditions and nutrient availability might be unfavourable for decomposition. In such cases elevated temperature will only affect decomposition if changes in soil physical conditions and/or nutrient status occur.

In the field it is hard to quantify the effects of increased temperature on decomposition of different SOM fractions. Incubating soil samples in the laboratory allows the effects of temperature, moisture, substrate quality and nutrient status to be separated. C mineralization will be measured by capturing  $\text{CO}_2$  using the Respicond III (Nordgren 1988). With this equipment samples can be incubated at constant temperature and moisture levels. Soil samples taken from the same location as the columns are incubated for two weeks at 5, 10 and 15 °C.

Up to five moisture levels will be maintained corresponding with those found in the soil columns. In addition three different amounts of N will be added.

### **Data evaluation**

Various models have been developed to describe SOM dynamics; the CENTURY model (Parton et al. 1987) is probably the best-known example. Since these models are generally poor at describing relationships between biological processes and substrate quality, however, they are probably too rigid to describe long-term effects of climate change (Van Breemen and Van Dam 1993). The NIICCE model (Van Dam and Van Breemen 1994) might provide the necessary refinement. In this model composition of plant litter is considered in terms of carbohydrates, proteins, hemicellulose and lignin contents. Microbial biomass with a variable C/N ratio is explicitly simulated. SOM is divided in three pools with different turnover times as is often used in other models (Van Veen et al. 1985, Parton et al. 1988, Hsieh 1989). NIICCE also allows for the description of  $^{13}\text{C}$  and  $^{15}\text{N}$  isotope concentration in different compartments within an ecosystem.

### **3. Timetable**

All measurements carried out in the pre-treatment year will be continued for at least three years. In October 1994 litterbags containing *Calluna* litter grown at ambient and elevated  $\text{CO}_2$  were incubated. In October of each year, samples will be taken for  $^{13}\text{C}$  and  $^{14}\text{C}$  analysis.

### **4. References**

- Balesdent, J., Mariotti, A., and Guillet, B. 1987. Natural  $^{13}\text{C}$  abundance as a tracer for studies of soil organic matter dynamics. *Soil Biol. Biochem.* 19: 25-35
- Couteaux, M.M., Bottner, P., Rouhier, H., and Billes, G. 1992. Atmospheric  $\text{CO}_2$  increase and plant material quality: production, nitrogen allocation and litter decomposition of sweet chestnut. p. 429-436. In: A. Teller, P. Mathy and J.N.R. Jeffers (eds.) Responses of forest ecosystems to environmental changes. Proc. First European Symposium on Terrestrial Ecosystems. Elsevier Applied Science, London & N.Y., 1009 pp.
- Goudriaan, J. 1992. Biosphere structure, carbon sequestering potential, and the atmospheric  $^{14}\text{C}$  record. *J. Exp. Botany* 43: 1111-1119
- Hsieh, Y.-P. 1989. The dynamics of soil organic matter formation in croplands -- conceptual analysis. *Science of the Total Environment* 81-82: 381-390.
- Leavitt, S.W., Paul, E.A., Kimball, B.A., Hendrey, G.R., Mauny, J.R., Rauschkolb, R., Rogers Jr. H., Lewin, K.F., Nagy, J., Pinter, P.J., and Johnson, H.B. 1994. Carbon isotopes in soils indicate rapid input of carbon under Free-air  $\text{CO}_2$  enrichment. *Agr. and Forest Meteorology* (in press)
- Leenheer, J.A., and Huffman, E.W.D., Jr. 1979. Analytical method for dissolved organic carbon fractionation: U.S. Geological Survey Water-Resources Investigations 79-4, 16 pp.

- Mooney, H.A., Drake, B.G., Luxmoore, R.J., Oechel, W.G., and Pitelka, L.F. 1991. Predicting ecosystem responses to elevated CO<sub>2</sub> concentrations. *BioScience* 41: 96-104
- Nordgren, A. 1988. Apparatus for the continuous, long-term monitoring of soil respiration in large numbers of samples. *Soil. Biol. Biochem.* 20: 955-957
- Parton, W.J., Schimel, D.S., Cole, C.V., and Ojima, D.S. 1987. Analysis of factors controlling soil organic matter levels in Great Plains grasslands. *Soil Sci. Soc. Am. J.* 51: 1173-1179
- Parton, W.J., Stewart, J.W.B., and Cole, C.V. 1988. Dynamics of C, N, P, and S in grassland soils: a model. *Biogeochem.* 5: 109-132
- Raison, R.J., Connell, M.J., and Khanna, P.K. 1987. Methodology for studying fluxes of soil mineral-N in situ. *Soil Biol. Biochem.* 19: 521-530
- Swift, M.J., Heal, O.W., and Anderson, J.M. 1979. Decomposition in terrestrial ecosystems. *Studies in Ecology*. Vol. 5, Blackwell Scientific Publications, Oxford etc., 372 pp.
- Van Breemen, N., and Van Dam, D. 1993. Studying effects of elevated CO<sub>2</sub> on decomposition of soil organic matter. In: *Methodologies to assess CO<sub>2</sub> effects on terrestrial ecosystems*. Ecosystem Research Report 6.
- Van Dam, D., and Van Breemen, N. 1994. NIICCE: A model for cycling of Nitrogen and Carbon isotopes in coniferous forest ecosystems. *Modelling of Geo-Biosphere Processes*, in press.
- Van Veen, J.A., Ladd, J.N., and Amato, M. 1985. Turnover of carbon and nitrogen through the microbial biomass in a sandy loam and a clay soil incubated with [<sup>14</sup>C(U)]glucose and [<sup>15</sup>N](NH<sub>4</sub>)<sub>2</sub>SO<sub>4</sub> under different moisture regimes. *Soil Biol. Biochem.* 17: 747-756
- Veldkamp, E. 1993. Soil organic carbon dynamics in pastures established after deforestation in the humid tropics of Costa Rica. Ph.D thesis, Wageningen Agr. Univ., 117 pp.

# Chapter 6

## *Plant Productivity and Turnover*

---

W. Arp<sup>1,2</sup> and F. Berendse<sup>2</sup>

<sup>1</sup>DLO Centre for Agrobiological Research  
P.O. Box 14  
6700 AA Wageningen  
The Netherlands

<sup>2</sup>Dept. of Terrestrial Ecology and Nature Conservation  
Wageningen Agricultural University  
Bornsesteeg 47  
6708 PD Wageningen  
The Netherlands

### **Summary**

The interaction observed between CO<sub>2</sub>, nitrogen and water is relevant for the field experiment in Risdalsheia. An increase in N availability will enhance the growth-stimulating effect of CO<sub>2</sub>, while a lower N supply will limit the response to growth. How N availability is affected depends on the opposing effects of an increase in temperature and a lower litter quality on decomposition.

A reduction in water use may increase the soil moisture content and stimulate the decomposition process, allowing species such as *Calluna* to better withstand periods of drought. However, a higher temperature will counteract this effect by enhancing evapotranspiration. Knowledge of the effects of CO<sub>2</sub> concentration and temperature on water use of the vegetation, drought resistance and soil moisture content will be important to understanding the ecosystem response to climate change.

### **1. Introduction**

Both a temperature and a CO<sub>2</sub> increase may increase primary production and biomass turnover, and a higher temperature can also enhance the rate of decomposition and nutrient mineralization, increasing the availability of nitrogen in the soil. However, an elevated CO<sub>2</sub> concentration may have an opposing effect on nitrogen cycling if the plant material produced contains more refractory compounds and has a lower nitrogen content (higher C/N ratio). In these nutrient-poor ecosystems plant production is limited by the available nutrients, and changes in the availability of nutrients caused by the increase in temperature and CO<sub>2</sub> are therefore of major importance.

Whereas high CO<sub>2</sub> often reduces transpiration, a higher temperature could enhance water use. Because CO<sub>2</sub> and temperature have opposing effects it is difficult to predict the net impact of climate change on the availability of nutrients and water in terrestrial ecosystems. This can have a direct effect on plant growth and survival during periods of drought (and thus

productivity and turnover) as well as indirectly affecting the rate of decomposition and mineralization.

In nutrient-limited environments the success of plants is dependent on their ability to maximise uptake of nutrients from the soil, or to minimise the loss of nutrients from the plant. Many plant species adapted to these environments have leaves which last for several seasons, thereby reducing the loss of nutrients through litter production. In Risdalsheia these evergreen species include *Calluna vulgaris*, *Pinus sylvestris* and some *Vaccinium* species. Production of these leaves, which have a high lignin content, is costly with respect to energy and carbohydrates, however, resulting in a slow growth rate. The high lignin and low nitrogen content in the litter of these plants also limits the decomposition rate (Van Vuuren et al. 1993), reducing the availability of nutrients.

An increased nutrient input to these ecosystems generally results in an increase in the biomass of faster-growing species, and a reduction in the biomass of the slower-growing plants adapted to the nutrient-poor environment. An example of this process is the replacement of *Calluna vulgaris* and *Erica tetralix* by *Molinia caerulea* and *Deschampsia flexuosa* resulting from increased nitrogen deposition on heathlands in the Netherlands.

Elevated CO<sub>2</sub> could affect plant productivity, nutrient status and decomposition in a variety of different (sometimes opposite) ways. Decomposition may be slowed if the lignin content or the C/N ratio of the litter increases. CO<sub>2</sub> can, however, enhance nitrogen uptake by plants through increasing root growth and stimulating mycorrhizal activity.

In high CO<sub>2</sub>, fewer enzymes of the photosynthetic and photorespiratory cycles are required to achieve the same photosynthetic rate, and the nitrogen in these enzymes can be reallocated to other more limiting processes, resulting in a higher nitrogen use efficiency (Conroy 1992) and a decreased nitrogen concentration in needles and leaves (Cure et al. 1988). However, because the nitrogen in these enzymes is the most easily withdrawn pool during leaf senescence, withdrawal of nitrogen from the senescing plant parts becomes less efficient, and the loss of nitrogen from the plant through litter production may actually increase (Arp and Berendse 1993). This will have a negative effect on the availability of nutrients for the vegetation.

The effects of elevated CO<sub>2</sub> and increased temperature on productivity of plants and turnover of carbon and nitrogen are studied in CLIMEX using the dwarf shrubs *Calluna vulgaris* and *Vaccinium myrtillus*, the dominant species in the ground vegetation of Risdalsheia. The effects of these treatments on growth and nutrient status of plants in nutrient-limited ecosystems are studied using two different approaches: (1) monitoring growth, nutrient status and turnover in *Calluna vulgaris* and *Vaccinium myrtillus* in the CLIMEX catchments, and (2) studying the effect on individual species of elevated CO<sub>2</sub> and the interaction of CO<sub>2</sub> increase and nitrogen supply under controlled conditions in the greenhouse in Wageningen.

As an *ecosystem*-scale experiment CLIMEX is unique in imposing a CO<sub>2</sub> and temperature change on all the other environmental factors which influence plant growth, as would be the case in nature. However, this very strength is a weakness as it is then difficult to isolate the individual effects of each of these factors. Also, the combined application of increased temperature and increased CO<sub>2</sub> makes it difficult to attribute eventual effects of climate change on growth to one of these two factors. Finally, because CLIMEX is set up as a long-term experiment, destructive harvesting must be kept to an absolute minimum.

These problems can be partly overcome by simultaneously conducting greenhouse experiments in which the CO<sub>2</sub> and temperature treatment can be separated, where growth conditions are kept constant, and where all material can be harvested. Additional advantages are the possibility to apply different levels of nutrients, and to compare several different species.

## 2. Methods

### *Field Experiments*

#### *Selection of plots at Risdalsheia*

Plots of at least 4 m<sup>2</sup> dominated by either *Calluna* or *Vaccinium* were selected in the two roofed catchments KIM and EGIL and in the open reference catchment METTE (Figures 2.15-2.17). In KIM, five plots of *Calluna* and *Vaccinium* were selected in both the control and experimental part of the enclosure. In EGIL, which is divided into a control section and a section where the soil temperature will be raised, only *Calluna* plots were mapped, because *Vaccinium* is only present in low numbers. In METTE, five *Calluna* and five *Vaccinium* plots were selected. The plots are used for sampling plant material, for following the growth of individual shoots, and for studying root growth and turnover (they are also used in the mineralization studies, Chapter 5). Growth and turnover of individual roots are examined using mini-rhizotron systems, and root cores will be taken to determine the belowground biomass. The results obtained during 1993 provide the baseline data which will be used to identify pre-treatment differences between the catchments, and between the future "ambient" and "elevated" parts within the KIM and EGIL catchments.

#### *Mini-rhizotrons*

Mini-rhizotrons were installed in each of the 40 *Calluna* and *Vaccinium* plots in August 1992. The maximum length of the mini-rhizotron tubes is 50 cm, but due to the shallow soil in the catchments most tubes were shortened. The rhizotron tubes in the shallow *Calluna* plots are often very short. Root growth and root turnover is measured by comparing photographs made at different times during the growing season. Each photograph shows a section of the mini-rhizotron wall of approximately 7.75 cm<sup>2</sup>. In order to follow the growth and turnover of individual roots, the same areas are photographed each time. At three times during 1993, photographs were taken at three depths in the *Calluna* plots (where possible). At each measurement depth 2 photographs are taken, one upward at a 45° angle to the left, the other 45° to the right. In the deepest *Vaccinium* mini-rhizotron photographs were taken at four depths. This procedure will be repeated each year.

#### *Sampling of plant material*

At four dates in 1993, two shoots each of *Calluna* and *Vaccinium* were harvested from each plot for determining growth, senescence, reproductive status, and the content of C, N, starch, lignin and cellulose. To minimise negative effects on the vegetation only branches with a maximum age of four years were harvested. At the end of the season root cores were taken from each plot to determine below-ground biomass, and for chemical analysis.

#### *Non-destructive measurements*

In order to assess the effects of increased CO<sub>2</sub> and temperature on individual plants in the field, 5 *Vaccinium* or *Calluna* plants in each plot (25 plants per treatment) were selected and labelled in spring 1993. *Vaccinium* and *Calluna* plants show a distinct seasonal growth pattern which makes it possible to identify shoot segments formed in previous years. On each plant

the stem diameter, segment length and number of branches on each segment (cohort) were measured for the last four cohorts (formed in 1990 to 1993) at four times during the growing season 1993. For *Vaccinium* the number of leaves on the youngest segment, and for *Calluna* the number of long and short shoots were also measured. Because these measurements are non-destructive, the same plants can be followed during the course of the experiment.

### *Greenhouse Experiments*

In 1993 a greenhouse experiment was conducted to investigate the effects of increased CO<sub>2</sub> under two levels of available nitrogen on growth and the turnover of carbon and nutrients. Plants were grown in two greenhouses in Wageningen, one at ambient CO<sub>2</sub> (350 ppm), the other at elevated CO<sub>2</sub> (560 ppm). The two nitrogen levels used represent the natural nutrient-poor situation, and a potential higher N availability resulting from an increased rate of mineralization, or from enhanced N deposition.

Five species were selected for this experiment. Three of them, *Calluna vulgaris*, *Vaccinium myrtillus* and *Molinia caerulea* occur both in the CLIMEX sites and in heathlands in the Netherlands. *Calluna* and *Vaccinium* are the subject of our field research in Risdalsheia. *Molinia* is of great importance because it appears to be replacing *Calluna* as a dominant species in dry heathlands of the Netherlands impacted by high nitrogen deposition (Berendse and Elberse 1990). The other two species, the dicot *Rumex obtusifolius* and the monocot *Arrhenatherum elatius* are included in the experiment because they are fast-growing plants. There is some indication that slow-growing species benefit much less from the growth-stimulating effect of elevated CO<sub>2</sub> than fast-growing species (Hunt 1991, Poorter 1993). This experiment enables us to investigate whether this difference in response to CO<sub>2</sub> also occurs in nutrient-limiting conditions, and how it may change if the nutrient supply increases. Combined with data on nutrient reallocation and turnover, this information can be used to predict shifts in species composition as a result of climate change.

Plants were grown in 6 l pots filled with either a nutrient-poor mixture of soil and sand or with the same mixture to which nitrogen in the form of a slow-release fertilizer is added. For each treatment 15 pots were used, with 3 plants per pot. To determine the growth, allocation and turnover of C and N, plants were harvested at three times during the season: at peak biomass (July), during senescence (October), and when senescence had been completed or growth had stopped (January). At each harvest the different plant parts were separated and weighed. Samples were taken for C, N, starch, lignin and cellulose analysis. The water use of all plants was measured by weighing each pot every week.

## **3. Results**

### *Field Experiments*

#### *Growth measurements*

The measurements made in 1993 serve as a control for the measurements which will be made in subsequent years, and also allow us to identify initial differences between the sites which are selected for the different treatments. For *Calluna vulgaris* differences between plots from KIM (clean rain), EGIL (roofed control) and METTE (non-roofed control) may provide information on the effects of acid rain (differences between KIM and EGIL plots) and the effects of the roof (differences between EGIL and METTE). The effects of acid rain or the

roof cannot be separated for *Vaccinium myrtillus* because there are no *Vaccinium* plots in the EGIL catchment.

### ***Vaccinium* growth during 1993**

The diameters of *Vaccinium* stems were the same for plants from both KIM sites, but the stems of plants in the non-roofed control site (METTE) were significantly thinner (Figure 6.1). No increase in stem diameter was observed during the course of the growing season for any of the cohorts (Figure 6.2). Because there are significant differences in stem diameter between cohorts, the increase in stem diameter must occur during the remaining period of the year. We expect to measure this in 1994.

There is no difference between the sites in the number of branches along *Vaccinium* stems. The number of branches on a shoot segment decreases with the age of the cohort, suggesting that a fraction of the branches dies off each year. On the other hand, the length of the shoot segments increases with age. This may be caused by climatic differences between years, but it is also possible that relatively more short branches die off, while the longer branches survive. Shoot segments of plants in the control site are significantly shorter than shoot segments of plants in both sections of the KIM catchment.

The number of leaves is also dependent on the location, with branches in the non-roofed control site (METTE) carrying significantly fewer leaves than branches of plants in KIM (Figure 6.3). This may be related to the shorter length of branches in KIM. Plants in the experimental section of KIM lost their leaves more quickly than plants in the control part of KIM (Figure 6.3). There are no differences in the percentage of green leaf surface between the sites, and the leaves in all sites start turning brown in August.

### ***Calluna* growth during 1993**

Stem diameters of *Calluna* were not significantly different among the catchments. However, a significant difference was found between *Calluna* shoots from the control and experimental part of KIM catchment, with plants from the control site having thinner shoots for all cohorts (Figure 6.4). Unlike *Vaccinium*, the shoots of *Calluna* did show an increase in stem diameter during summer (Figure 6.5), with additional growth expected during the remainder of the year. There were no significant differences in shoot length or number of branches between sites. The number of branches declined with cohort age, signifying a loss of branches over time.

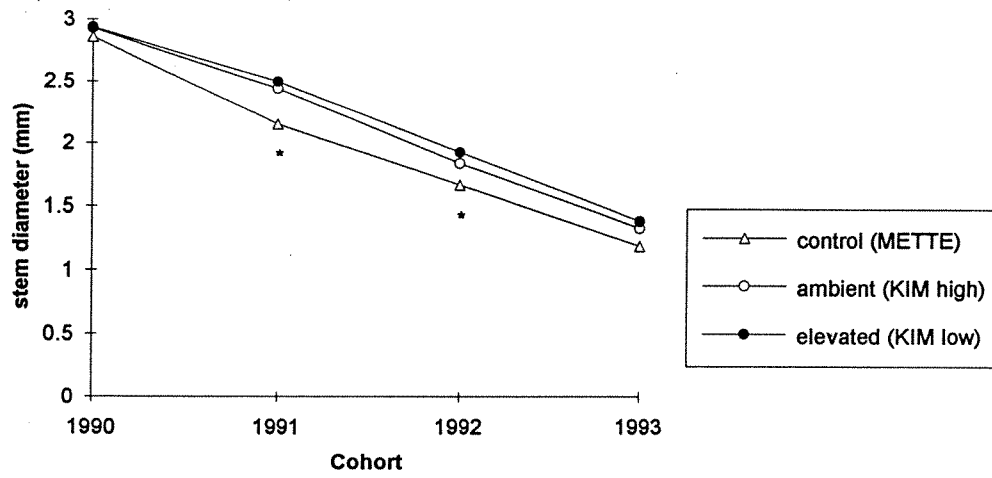
The number of short shoots and flowers on the youngest cohort was also measured. The number of short shoots declined during the course of the season (Figure 6.6). *Calluna* plants in METTE had more short shoots than plants in KIM or EGIL, suggesting a roof effect. Flowering was also more abundant in METTE. In KIM, plants from the control section had more short shoots than plants from the experimental section.

### ***Initial differences in plant growth***

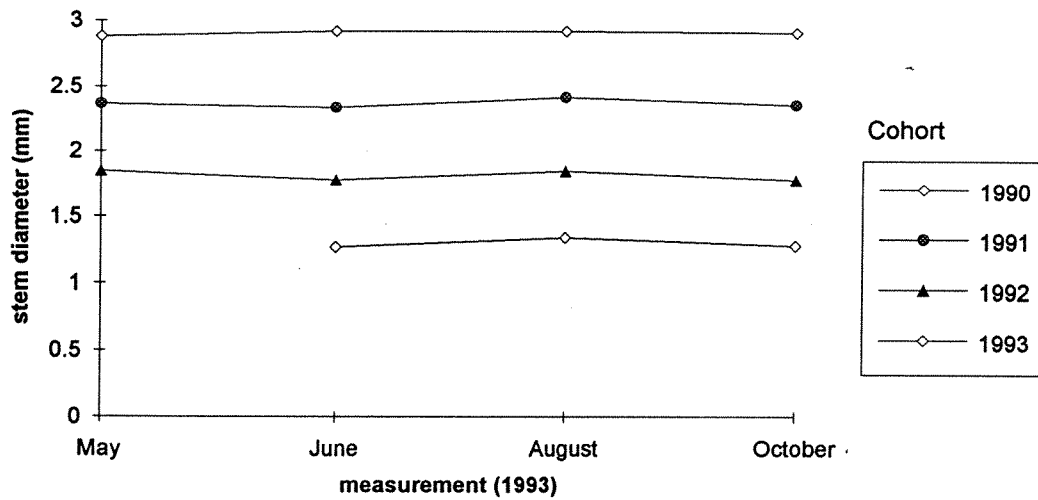
There appear to be some initial differences between the two sections in KIM. *Calluna* stems in the control section of KIM are slightly thinner and shorter than the stems in the experimental part, but have more short shoots. *Vaccinium* leaves appear to senesce more quickly in the experimental part of KIM.

A possible effect of the RAIN treatment is that *Vaccinium* shoots are thicker, longer and

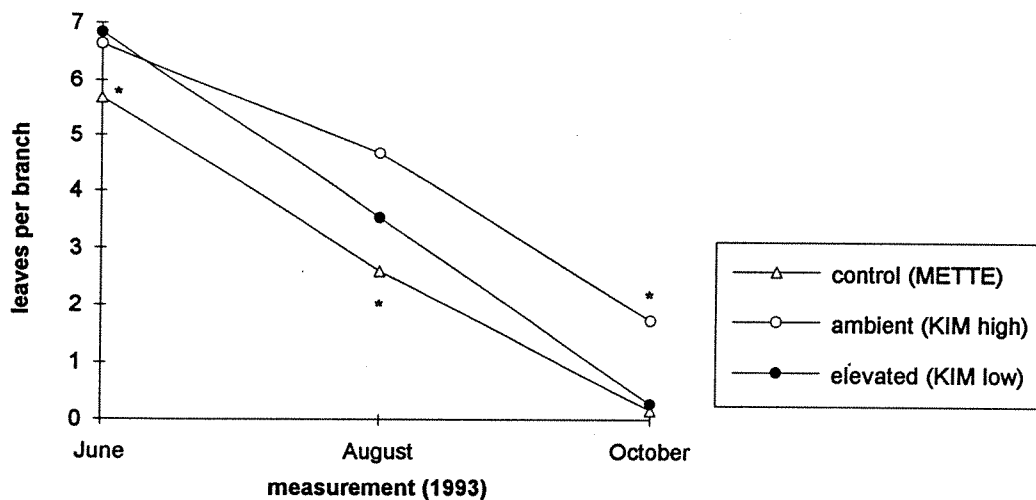




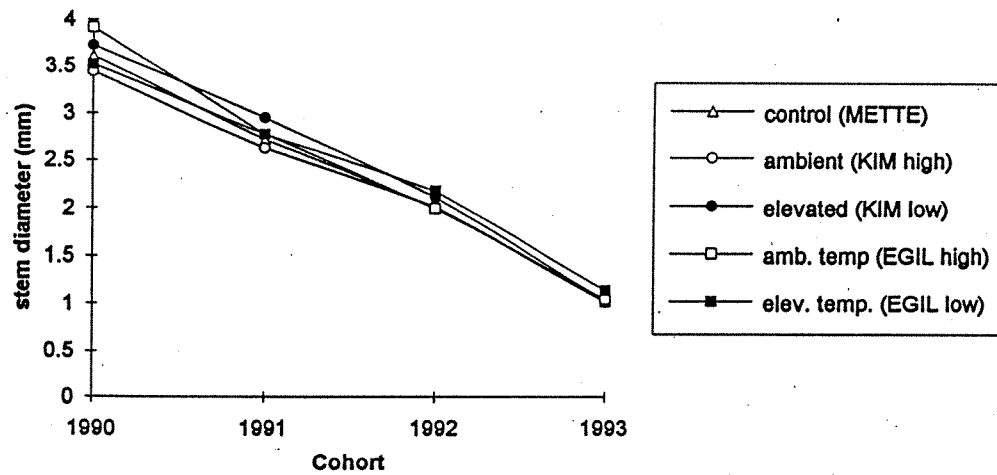
**Figure 6.1** Diameter of *Vaccinium* stems of different age cohorts, in the three sites. Data from four measurements are pooled ( $n = \pm 95$ ). Means that are different at the 0.05 level of significance are marked with an asterisk.



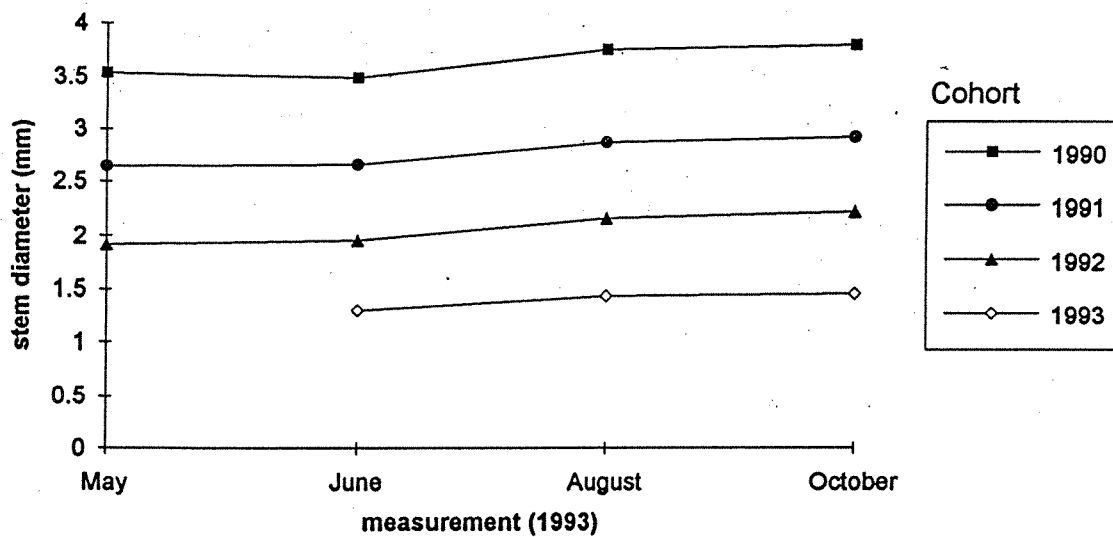
**Figure 6.2** Diameter of *Vaccinium* stems of different age cohorts, measured at four times in 1993. Data for different sites are pooled ( $n = \pm 70$ ).



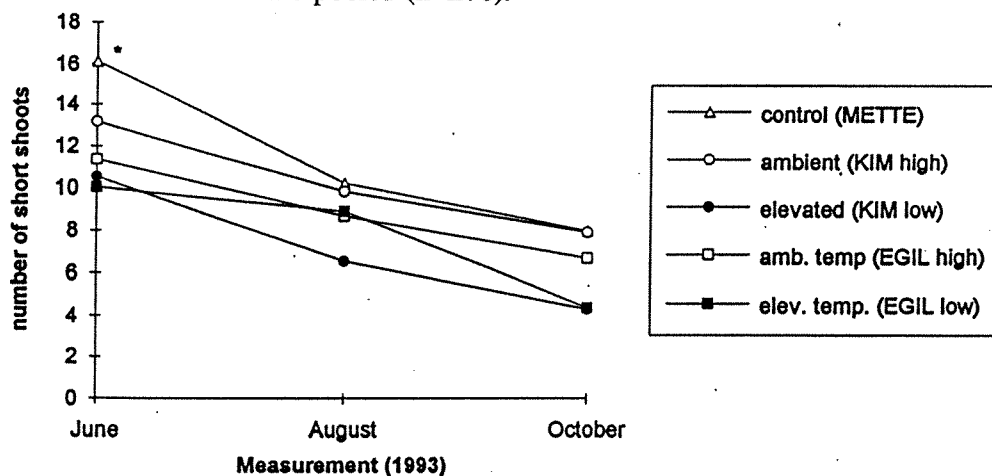
**Figure 6.3** Number of leaves per branch of *Vaccinium myrtillus*, for three measurement times and for the three sites. Means that are different at the 0.05 level of significance are marked "\*".



**Figure 6.4** Diameter of stems of *Calluna vulgaris* of different age cohorts, in the five sites. Data from four measurements are pooled ( $n=\pm 95$ ). Shown are mean and standard error.



**Figure 6.5** Diameter of *Calluna vulgaris* stems of different age cohorts, measured at four times in 1993. Data for different sites are pooled ( $n=\pm 70$ ).



**Figure 6.6** Number of short shoots per branch of *Calluna vulgaris*, for three measurement times and for the five locations. Means that are different at the 0.05 level of significance are marked with an asterisk.

have more leaves in the KIM catchment. This can be an effect of the roof or of the different composition of precipitation. The larger number of short shoots and flowers of *Calluna* plants in METTE compared to plants in the other catchments appears to be a roof effect (plants are more shaded in KIM and EGIL). These initial differences in plant growth will be taken into account when examining the effects of increased CO<sub>2</sub> and temperature on growth of these plants.

### Greenhouse Experiments

Data collection and analysis of all three harvests has been completed for the two grass species *Molinia* and *Arrhenatherum*.

#### *Molinia caerulea*

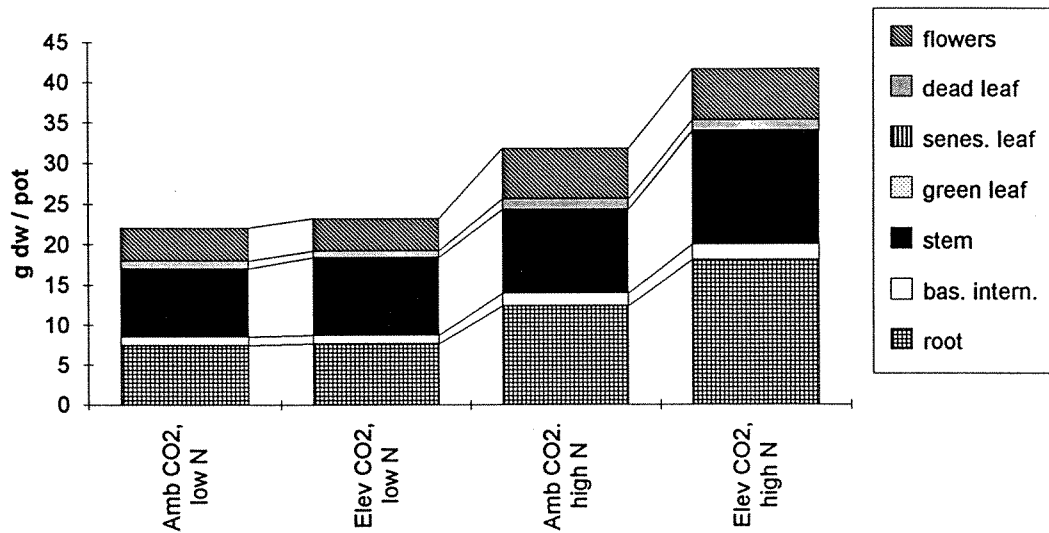
Nitrogen greatly stimulates the growth of *Molinia*, and the relative effect of N on biomass increases with time. All plant parts show an increase in biomass, although the roots show the largest growth increase (Figure 6.7). Elevated CO<sub>2</sub> also stimulates growth, but this is only significant when plants are "released" from limiting amounts of N (Figure 6.8a). The highest growth stimulation and biomass at final harvest comes with combined high N and high CO<sub>2</sub>. This biomass increase is mainly allocated to roots, stems and basal internodes. Both N and CO<sub>2</sub> cause an increase in the number of shoots and leaves.

An increase in water use (Figure 6.8b) matches the increase in biomass at high N and ambient CO<sub>2</sub> (Figure 6.8a). The water use *efficiency* is therefore not affected by the N supply. At elevated CO<sub>2</sub>, the water use efficiency increased by about 50% at both nitrogen treatments, and at all harvests. At the final harvest 26% less water was used by the plants at high CO<sub>2</sub> (Figure 6.9). There is thus a large stimulation of growth by CO<sub>2</sub> at high N, with only a small reduction in water used, and a large reduction of water use by CO<sub>2</sub> at low N, with only a slight increase in biomass (Table 6.1). This pattern may reflect optimal use of nutrients (N and CO<sub>2</sub>) by the plant. At high N photosynthesis is stimulated by high CO<sub>2</sub> and the increased carbon supply stimulates growth. At low N, nitrogen is limiting the rate of photosynthesis, and elevated CO<sub>2</sub> will have a much smaller effect on carbon supply. In this case it is more efficient to make use of the high CO<sub>2</sub> concentration outside the leaf to close the stomata and reduce water loss. Because all plants were adequately supplied with water during the experiment, this water conservation strategy probably did not affect plant growth. However, in the field this behaviour would have a positive effect on plant growth and survival during periods of drought.

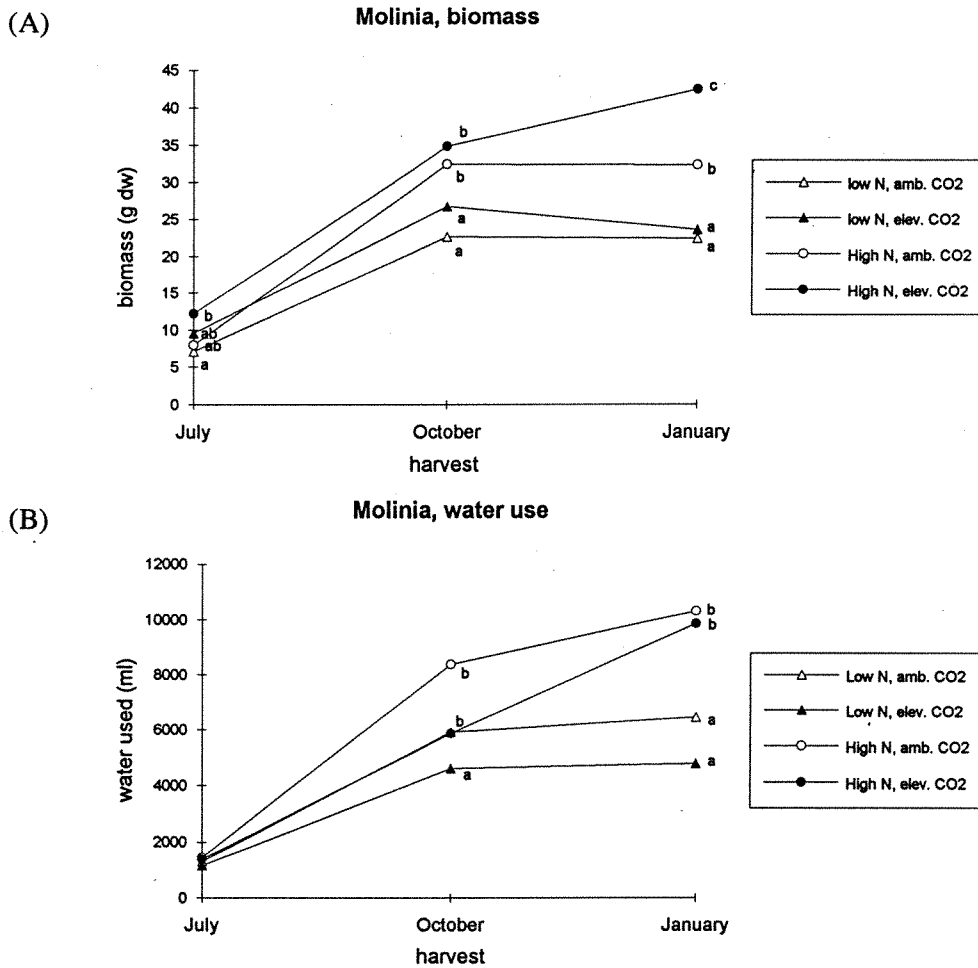
**Table 6.1** Combined effect of CO<sub>2</sub> and N on biomass, water use, and water use efficiency (WUE) of *Molinia caerulea*.

	High N	Low N
Effect of elevated CO <sub>2</sub>	↑↑ Biomass ↓ Water use ↑↑↑ WUE	↑ Biomass ↓↓ Water use ↑↑↑ WUE

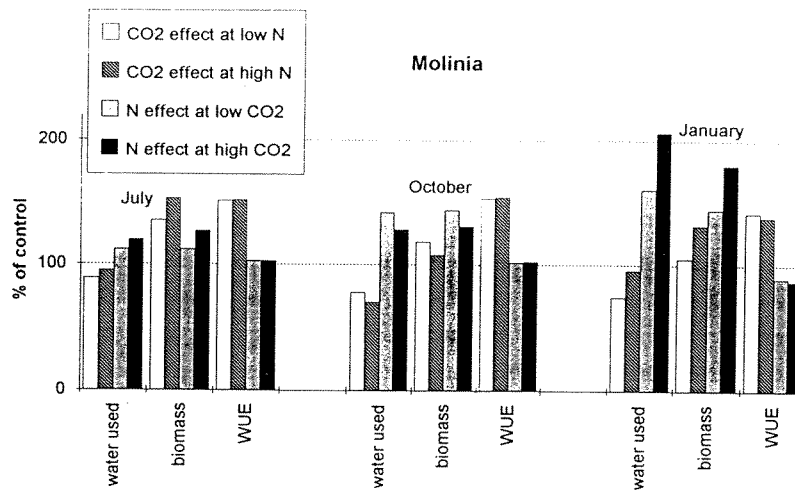
Molinia, biomass allocation, harvest 3



**Figure 6.7** Biomass allocation of *Molinia caerulea* to roots, basal internodes, stems, green leaves, senescing leaves, dead leaves and flowers. The results are for plants grown for 8 months at two different CO<sub>2</sub> and N levels (n=5).

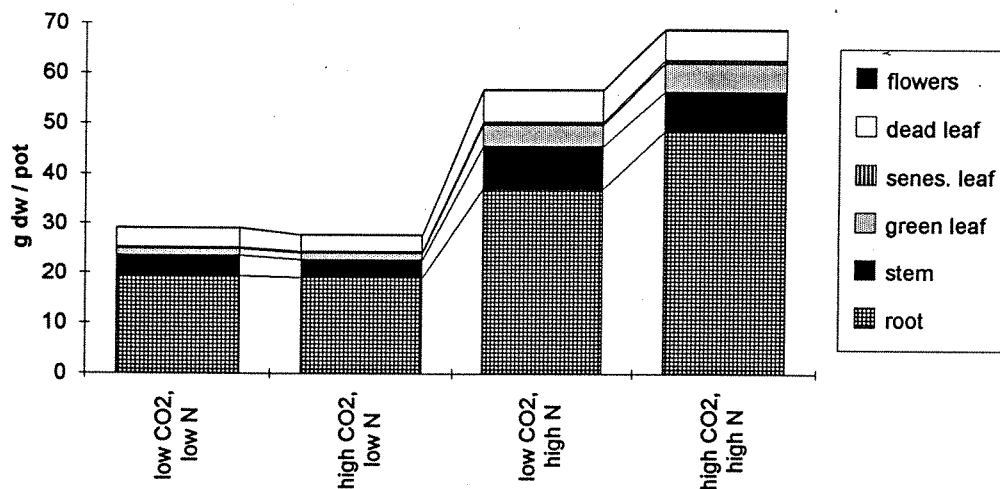


**Figure 6.8** Effect of elevated CO<sub>2</sub> and nitrogen supply on biomass (A) and accumulated water use (B) of *Molinia caerulea*, at three growth stages. Means that are different at the 0.05 level of significance are marked with different letters.



**Figure 6.9** Effect of elevated CO<sub>2</sub> and nitrogen on total water use, biomass and water use efficiency for *Molinia caerulea*. The effects of CO<sub>2</sub> and nitrogen are compared to the appropriate control treatment. Results are shown for all three harvests (July, October and January), N = 5.

**Arrhenatherum, biomass allocation, harvest 3**



**Figure 6.10** Biomass allocation of *Arrhenatherum elatius* to roots, stems, green leaves, senescing leaves, dead leaves and flowers. The results are for plants grown for 8 months at two different CO<sub>2</sub> and N levels, N = 5.

***Arrhenatherum elatius***

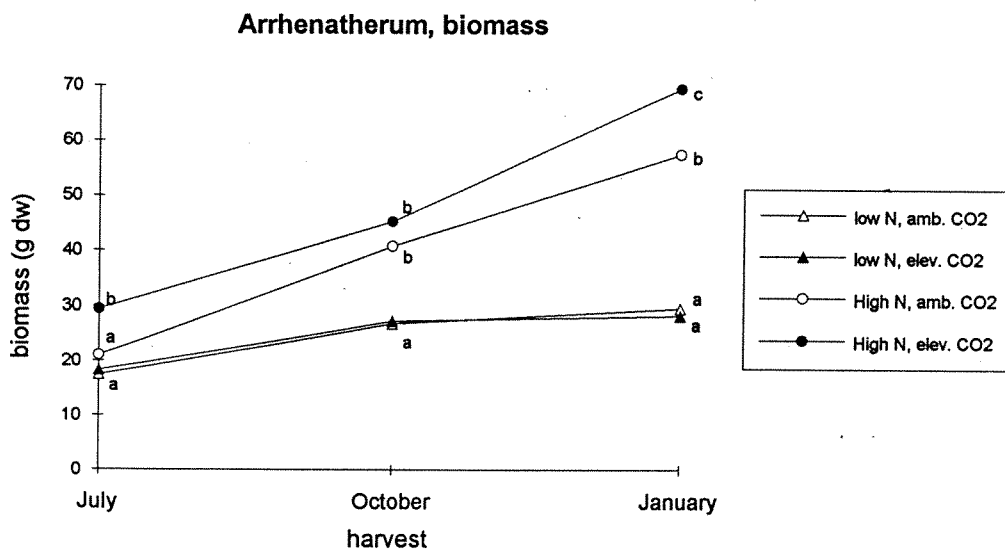
The effects of N and CO<sub>2</sub> on *Arrhenatherum elatius* are comparable to the effects on *Molinia* (Figure 6.10). Nitrogen stimulates growth, and at the end of the growing season the high N plants had double the biomass of the low N plants (Figure 6.11a). CO<sub>2</sub> also stimulates growth, but only when the N supply is high. At low N, the water use is significantly reduced by high CO<sub>2</sub> (Figure 6.11b). The water use efficiency is not affected by the N supply, but is increased at elevated CO<sub>2</sub> (Figure 6.12). At the second harvest both *Arrhenatherum* and *Molinia* show a relatively small increase in biomass at high CO<sub>2</sub> and high N but a large reduction in water use. This may be related to the higher temperatures, and possibly some drought stress during this stage of the experiment.

The growth stimulation by elevated CO<sub>2</sub> is almost completely caused by an increase in root biomass and green leaves. The growth-enhancing effect of N benefits all plant parts, but the green leaf fraction is stimulated the most. The leaf weight ratio (fraction of the total dry

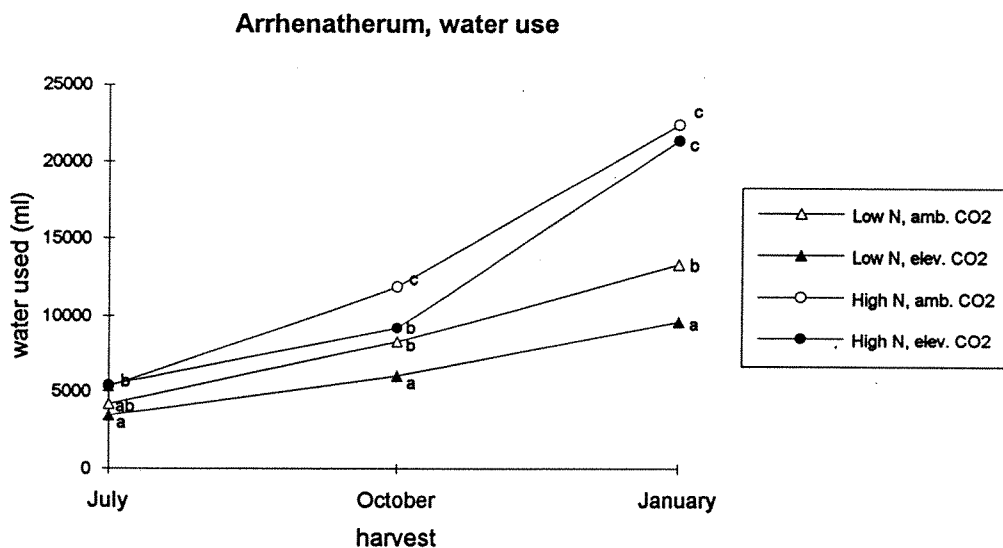
weight of the plant that is leaves) is not affected by high CO<sub>2</sub>, but shows a large increase with N. The number of leaves is higher in high N, but high CO<sub>2</sub> reduces this effect. However, both leaf size and the specific leaf weight increase for plants in high N and high CO<sub>2</sub>, resulting in a larger total leaf dry weight.

Although data analysis for the other species has not yet been completed for the last harvests, the available data show a picture similar to that described above. At high N, CO<sub>2</sub> stimulates growth, while at low N elevated CO<sub>2</sub> reduces the use of water. Results from the first harvest suggest that, contrary to expectation, slow-growing species respond more to high CO<sub>2</sub> than fast-growing species. It may be that even in the high N treatment the nitrogen content was too limiting for the fast-growing species to allow a large response.

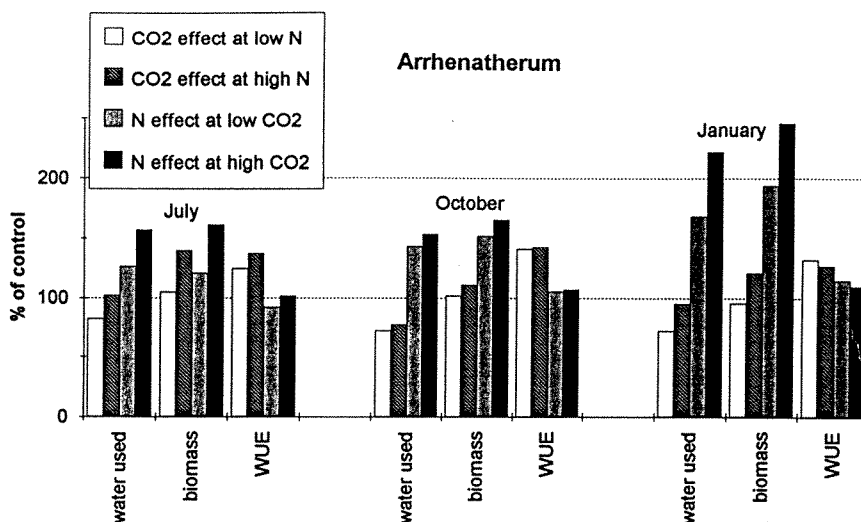
(A)



(B)



**Figure 6.11** Effect of elevated CO<sub>2</sub> and nitrogen supply on biomass (A) and accumulated water use (B) of *Arrhenatherum elatius*, at three growth stages. Means that are different at the 0.05 level of significance are marked with different letters.



**Figure 6.12** Effect of elevated CO<sub>2</sub> and nitrogen on total water use, biomass and water use efficiency for *Arrhenatherum elatius*. The effects of CO<sub>2</sub> and nitrogen are compared to the appropriate control treatment. Results are shown for all three harvests (July, October and January), N = 5.

#### 4. Timetable

The measurements made during the pre-treatment year will be repeated each season at approximately the same time of the year.

#### 5. References

- Arp, W.J. and Berendse, F. 1993. Plant growth and nutrient cycling in nutrient-poor ecosystems. In: Van de Geijn, S.C., Goudriaan, J. and Berendse, F. (eds.), *Climate change: crops and terrestrial ecosystems*. CABO-DLO, Wageningen, 109-123.
- Berendse, F. and Elberse, W.T. 1990. Competition and nutrient availability in heathland and grassland ecosystems. In: J.B. Grace and D. Tilman (Eds.), *Perspectives on plant competition*, Academic Press, San Diego, California, 93-116.
- Conroy, J.P. 1992. Influence of elevated atmospheric CO<sub>2</sub> concentrations on plant nutrition. *Australian Journal of Botany* 40: 445-456.
- Cure, J.D., Israel, D.W. and Rufty, T.W. 1988. Nitrogen stress effects on growth and seed yield of non-nodulated soybean exposed to elevated carbon dioxide. *Crop Science* 28: 671-677.
- Hunt, R., D.W. Hand, M.A. Hannah and Neal, A.M. 1991. Response to CO<sub>2</sub> enrichment in 27 herbaceous species. *Functional Ecology* 5, 410-421.
- Poorter, H. 1993. Interspecific variation in the growth response of plants to an elevated ambient CO<sub>2</sub> concentration. *Vegetatio* 104/105, 77-97.
- Van Vuuren, M.M.I., F. Berendse and W. De Visser 1993. Species and site differences in the decomposition of litters and roots from wet heathlands. *Canadian Journal of Botany* 71, 167-173.

# Chapter 7

## *Tree Nutrient Status and Growth*

---

E. D. Schulze, C. Thron and G. Schmidt

Institute for Plant Ecology  
University of Bayreuth  
95440 Bayreuth  
Germany

### Summary

It is difficult to draw general conclusions from the results obtained from the vegetation cover because (i) the acid-rain catchment has too few trees for any statistical comparison; (ii) the ROLF (reference) catchment proved unsuitable whereas the data from the METTE (reference) catchment is always between the EGIL (acid rain) and KIM (clean rain) catchments; (iii) no vegetation map exists which describes the ground cover at the start of the RAIN project; (iv) at present the EGIL (acid rain) catchment is dominated by *Calluna* but contains a stagnant boggy area in the centre characterised by *Narthetium ossifragum* whilst the KIM (clean rain) catchment is inherently different with no such wet spot and with *Vaccinium* and grasses dominant and *Calluna* existing only at the margins.

No significant differences exist in the ground cover vegetation between the clean and acid catchments. Nutritional differences exist between trees of the two catchments but these could also be due to differences in growth form.

Most striking is the difference in growth rate between trees in the clean- and acid catchments. These differences are in part due to higher temperatures close to the roof in the clean rain catchment. Smaller trees, however, also show higher growth rates, which appear to be related to better nutrition, but it remains unclear if this is due to inherent differences between these two catchments or due to the treatment effect.

### 1. Introduction

The objectives of this contribution to CLIMEX are to investigate changes in carbon fixation, carbon/nitrogen resource use and nutrient cycles of trees and shrubs in response to increased CO<sub>2</sub> and temperature. Initially, any effect of a roof or of eight years of ambient (acidic) and de-acidified precipitation input should be revealed by the pre-treatment nutrient status of trees and shrubs.



We have collected background data on tree growth characteristics and nutrient status as follows:

1. All trees in all catchments were characterized by growth form and dimensions.
2. Leaf biomass was estimated for birch (*Betula pubescens*).
3. Nutrient contents and concentrations of tree leaves and needles and above-ground parts of shrubs were measured.
4. Sequential harvests of needles over time were evaluated statistically with respect to nutrient status to evaluate assumptions about age-class distributions.

We hypothesize the following:

1. Increased CO<sub>2</sub> and temperature will lead to an initial enhancement of photosynthesis. This will lead to an *initial increase* in the C/N ratio of leaves.
2. Enhanced photosynthesis will lead to high levels of soluble carbohydrates in leaves which could increase nitrate reduction for incorporation into amino acids and improve the growing conditions of the tree (ultimate *reduction* in C/N ratios).
3. Since the clean rain treatment eliminated most of the inorganic N inputs (Chapter 4), plant availability of nitrogen should be lower at KIM than EGIL and ROLF. At the same time, the lower nitrate and sulphate flux out has resulted in lower base cation and aluminium concentrations in soil solution and runoff in KIM.
4. Because of the above, if either nitrogen or base cations (or a combination) limits growth, then the clean rain treatment in KIM should *decrease* plant growth. If climatic conditions such as temperature and wind stress limit growth, then the roof present in KIM (and ROLF) should *enhance* growth. Reduced concentrations of aluminium in soil solution would also lessen the potential for aluminum toxicity to roots in KIM and could also *enhance* growth in KIM.
5. Enhanced growth due to the temperature and CO<sub>2</sub> treatment may ultimately exacerbate nutrient imbalances in trees and shrubs.

## 2. Methods

### *Growth Analysis*

Height and circumference at breast height were measured for all trees in all five CLIMEX catchments in April 1992. Annual growth of pine (*Pinus sylvestris*) was reconstructed by measuring the stem length between annual whorls for trees in KIM, EGIL and CECILIE. All trees were assigned to three initial growth-form categories (normal, deformed growth, and dwarfed).

## Leaf Biomass

In August 1992 a subset of dominant birch trees selected from each catchment (Table 7.1) was wrapped in a net (mesh size 8-12 mm) which collected all the falling leaves. The net was removed in October and the leaves were dried and weighed, giving a leaf mass weight per tree. These measurements will be repeated on the same trees every October. Leaf area of the trees was measured in August by laying out fresh leaves on U.V.-sensitive paper, exposing the paper to the sun and tracing the outline with an area meter.

**Table 7.1** Number of trees sampled with normal upright growing shoots in CLIMEX catchments in October 1992. “-“ indicates that no sample tree was taken. The “total number“ includes all normal and deformed trees as well as seedlings.

Catchment	Sample Number		Total Number	
	<i>Pinus</i>	<i>Betula</i>	<i>Pinus</i>	<i>Betula</i>
KIM (roof, clean rain)	12	9	53	53
EGIL (roof, acid rain)	3	5	6	24
ROLF (open reference)	0	0	5	3
CECILIE (open reference)	5	2	18	3
METTE (open reference)	-	2	26	7
Surroundings	-	1	-	-

## Nutrient Contents and Concentrations

Pine needles, birch leaves and above-ground parts of understory vegetation were collected in KIM, EGIL and ROLF in 1990 and 1991, and in all catchments in 1992 using the same trees as the biomass measurement. The timing and age group of samples varied: in November 1990 current needles were collected, in August 1991 one-year-old needles were taken, and all age classes were sampled in April, August and October 1992. Birch leaves were collected in August 1991, and April and August 1992, while understory vegetation was sampled only in August 1991. About 20 needles per tree were harvested from *Pinus sylvestris* from the upper crown and the shaded crown, and five leaves were sampled from *Betula pubescens*

from each part of the crown. Leaves of *Vaccinium* and current shoots of *Calluna* were chosen for understory vegetation. Samples were dried, homogenized and analyzed by combustion for total C and N (Carlo Erba Automatic nitrogen analyzer Model 1500). Base cations were determined on acid-extracted samples by flame Atomic Adsorption spectroscopy. Concentrations of nitrogen reductase enzyme were also measured on vegetation in the CLIMEX catchments in August 1994. More details of the analytical procedures may be found in Thron (1993).

### *Sequential Sampling of Needles*

Element concentrations of needles in different age classes collected at the same time were compared with those of the same age class sampled sequentially over several years to determine if differences exist in these methods.

### *<sup>15</sup>N Isotopic Abundance*

Natural abundances of <sup>15</sup>N were measured in subsamples of pine needles, birch leaves and understory using the same samples as for element analyses. When less total N is available due to enhanced leaching, discrimination between isotope weights is decreased. <sup>15</sup>N analyses can indicate if a reduction in available nitrogen for plants is occurring under any of the treatments.

## **Results and Discussion**

### *Size Distribution of Trees*

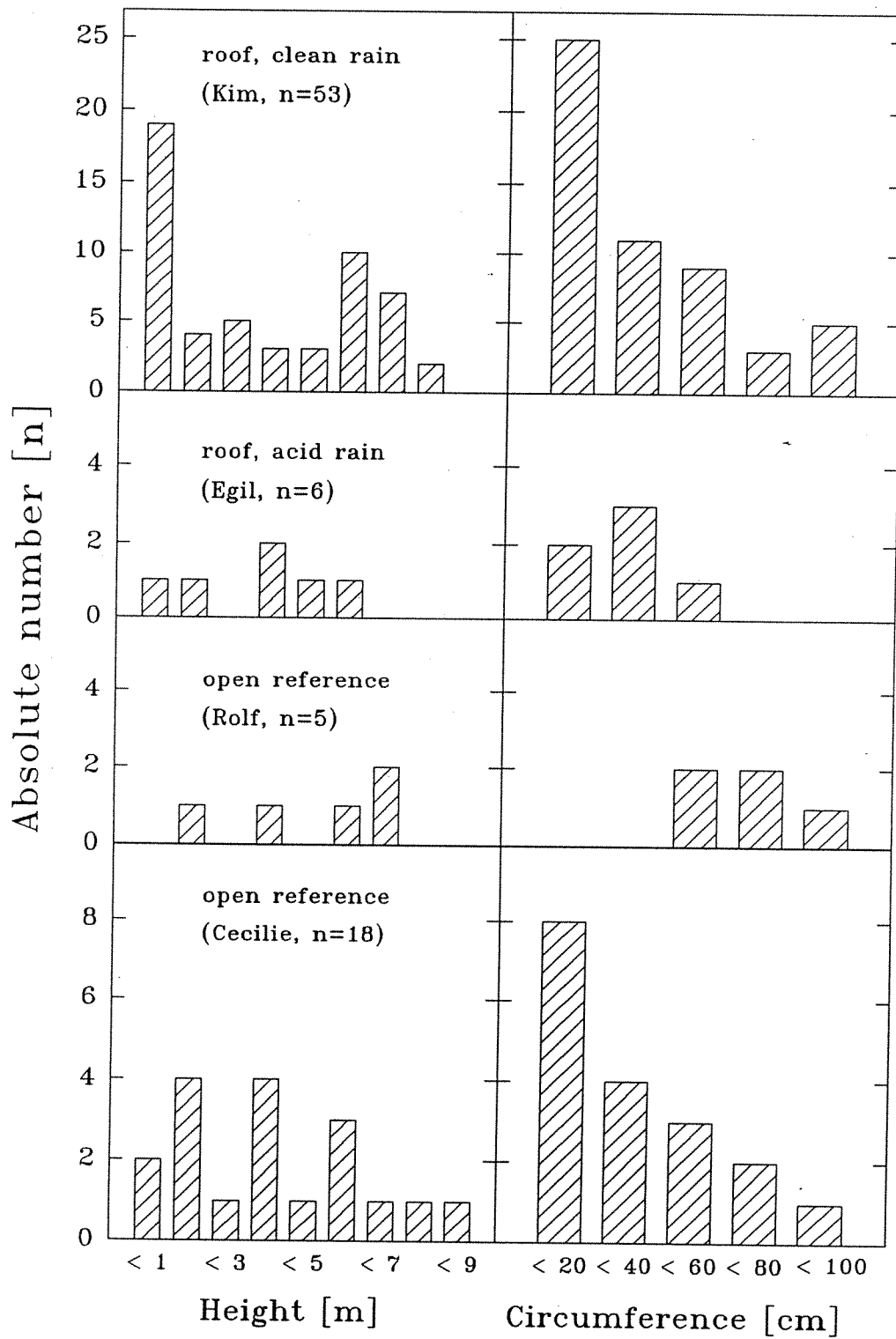
Both KIM and CECILIE have a relatively large number of trees, evenly distributed in ages and sizes (Figure 7.1). In contrast, EGIL and ROLF have fewer trees and are missing the higher size classes (> 7 m). Height growth was strongly enhanced in the clean-rain catchment KIM as compared to the acid rain catchments EGIL and CECILIE (Figure 7.2a). We speculate that this is due both to the clean rain treatment and to the fact that trees are taller in KIM and have reached the warmer region under the roof (Figure 7.2b). Enhanced growth is also seen in trees growing directly under the roof in EGIL (Figure 7.2c). However, smaller trees apparently also show enhanced growth under clean rain conditions (Figure 7.2b). This may partly be due to a combination of clean rain improving the soil chemical environment (decreased levels of inorganic aluminium), warmer soil temperatures under the roof, and the sprinkling of water in summer under drought conditions.

### *Leaf Biomass*

There was no difference among the catchments in either total leaf biomass per tree or leaf area (Table 7.2). On average, trees exposed to ambient rain had higher leaf biomass per stem area (sapwood) than trees under the clean rain treatment, but the differences are not statistically significant.

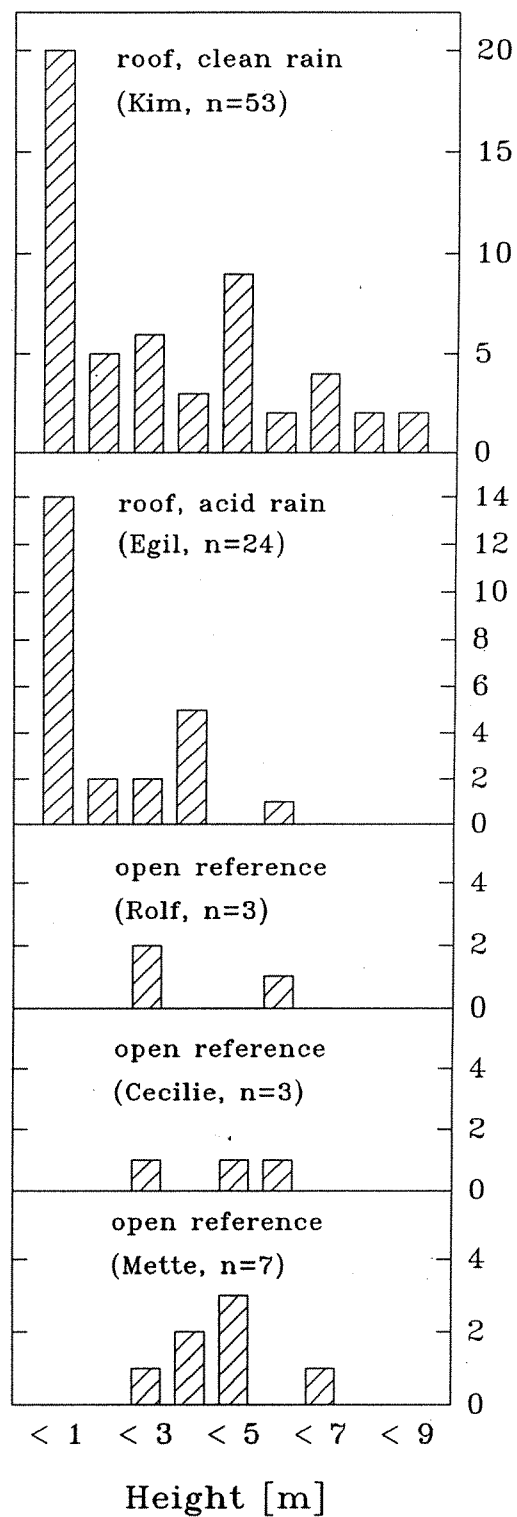
Risdalsheia, October 1992

*Pinus sylvestris*

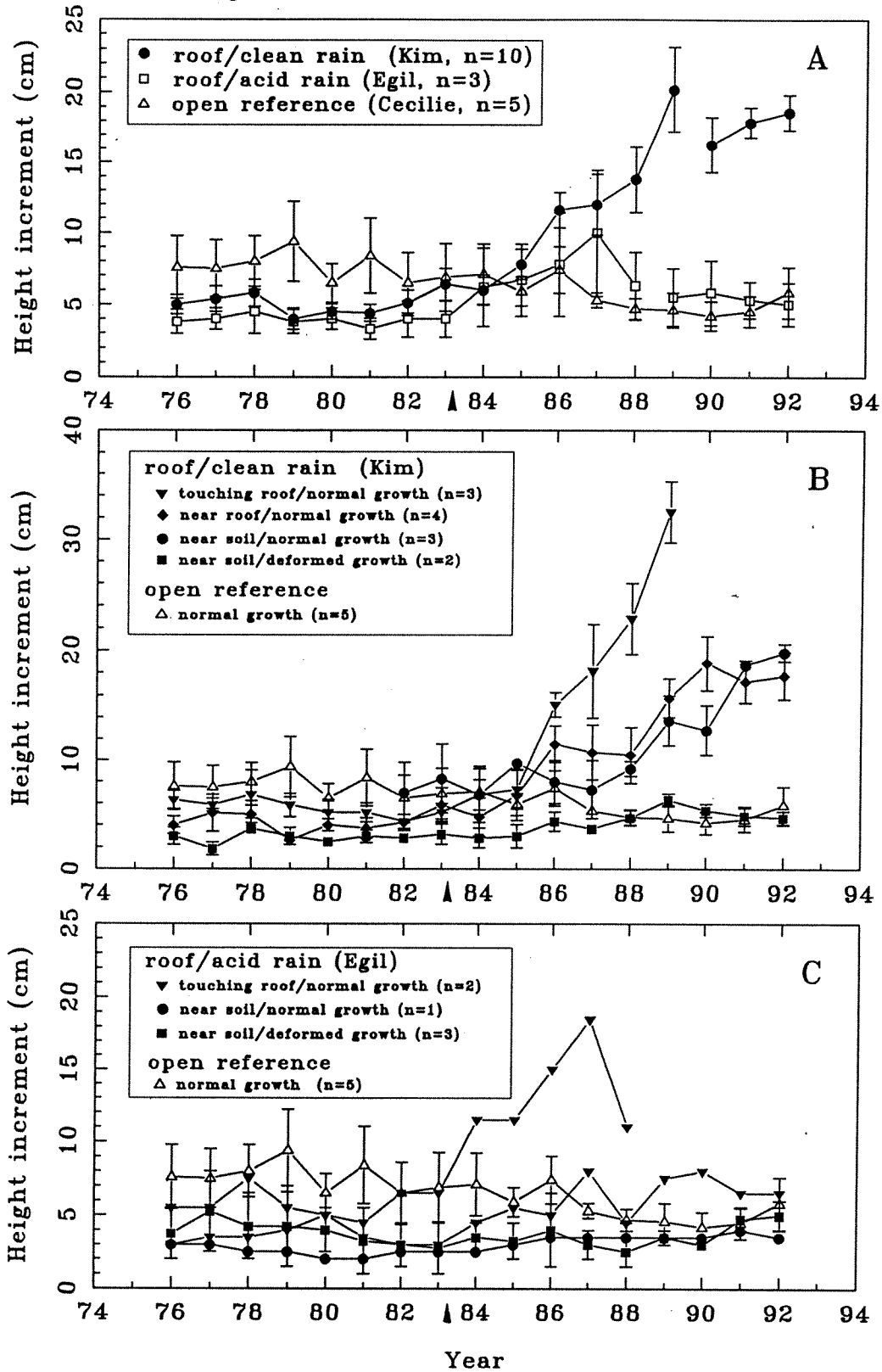


**Figure 7.1a** Distribution of height and circumference classes of *Pinus sylvestris* in the catchments in October 1992. The circumference was measured at breast height at 1.30 m.

*Betula pubescens*



**Figure 7.1b** Distribution of height and circumference classes of *Betula pubescens* in the catchments in October 1992. The circumference was measured at breast height at 1.30 m.



**Figure 7.2** Measurement of the annual shoot increment of the last 16 years (1976-1992) of *Pinus sylvestris* in 1992. The arrow marks the point of time when the roofs in the catchments were constructed. (a) Comparison of trees with normal upright growth form. The gap in the curves of KIM between 89/90 and of EGIL between 88/89 demonstrates the fact that some trees touched the roof and their shoot leaders died. (b) Comparison of trees in KIM with different positions and growth forms. (c) Comparison of trees in EGIL with different positions and growth forms. Data from measurements in CECILIE with normally-grown trees are also shown.

**Table 7.2** Leaf biomass (DW = dry weight) of *Betula pubescens* in October 1992. The data are subdivided into the upper and lower part of the crown, "total" crown = the mean value of upper and lower. Standard error in parentheses.

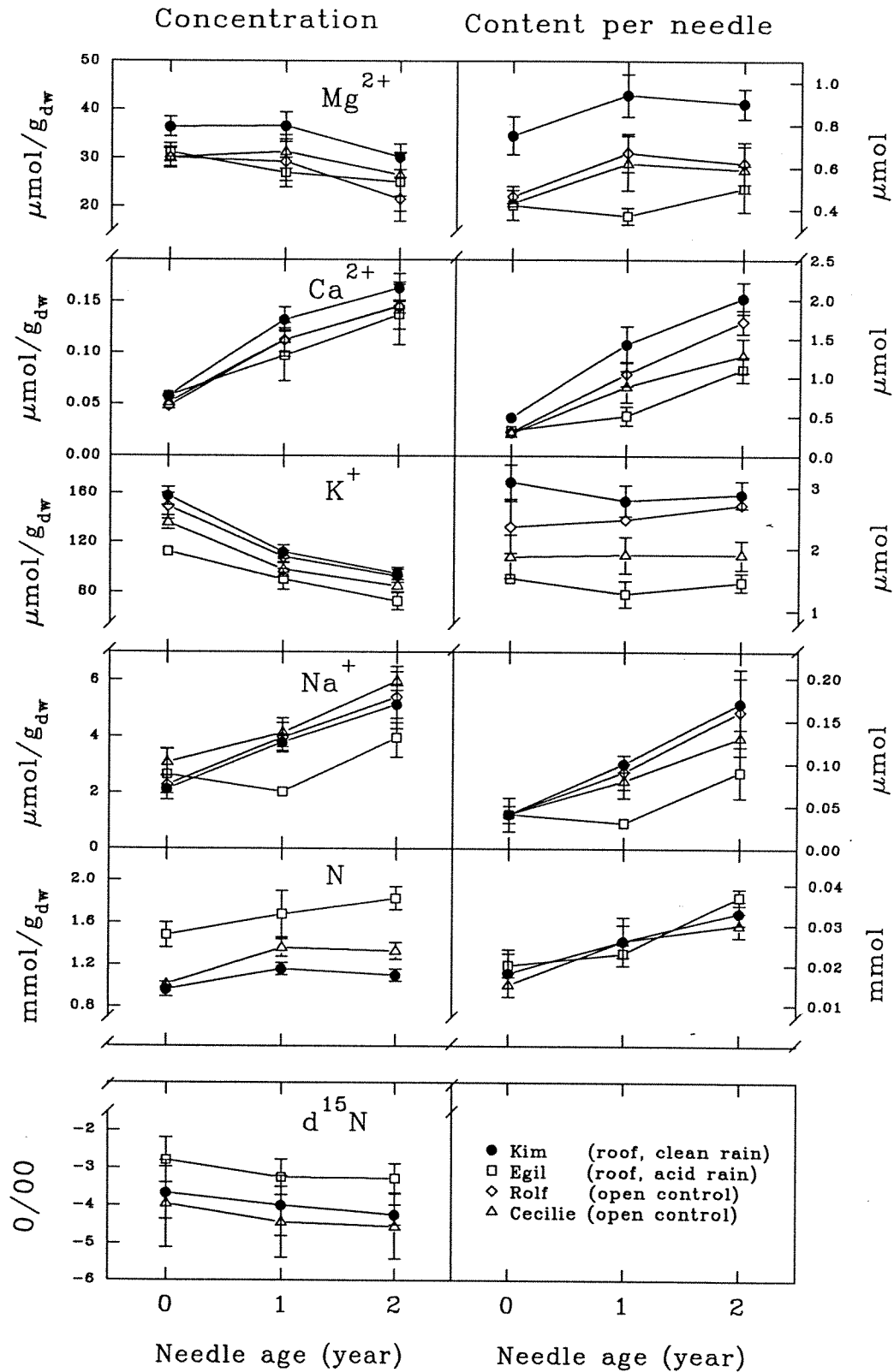
Catchment	n	Crown part	Leaf area (mm <sup>2</sup> )	DW/tree (g)	DW/sapwood (kg/m <sup>2</sup> )	Sapwood (mm <sup>2</sup> )	Height (m)
KIM	9	upper	832 (70)	330 (110)	47 (7)	6919 (1770)	3.82 (0.26)
		lower	907 (78)	320 (110)	46 (8)		
		total	870 (73)	325 (110)	46 (7)		
EGIL	5	upper	559 (52)	354 (150)	65 (11)	5478 (2375)	3.73 (0.52)
		lower	696 (17)	359 (124)	70 (12)		
		total	627 (27)	357 (136)	67 (11)		
Reference	5	upper	787 (115)	329 (113)	65 (21)	5307 (1372)	3.51 (0.66)
		lower	807 (127)	345 (122)	71 (24)		
		total	797 (120)	337 (118)	68 (22)		

## Nutrition

### Pine

The interpretation of nutrient data depends on the location of the tree (close to the ground or close to the roof) and on the time sequence of sampling. Obviously different environmental conditions between years, especially variation in precipitation, create differences in needle nutrition. Comparing nutrient status from several age classes collected at one time (e.g. in year 1992) gives different results from comparisons made from one shoot followed over time (Figure 7.3). By sampling all age classes at one time, significantly higher concentrations of magnesium and potassium were found between the roofed -clean rain (KIM) and -acid rain (EGIL) treatments in needles of all age classes (one-way ANOVA). Concentrations of calcium were also higher in one- and two-year old needles between KIM and EGIL. Concentrations of these elements in CECILE (open - acid rain) overlapped the other two. From this we conclude that the effect of the roof was not significant, but that there may be a clean rain effect.

Nitrogen concentration was higher in all age classes in both acid rain treatments, with and without a roof (EGIL and ROLF). Total nitrogen amount per needle, however, was approximately the same. We conclude from this that nitrogen in itself is not limiting growth in the catchments (also supported by the height measurements). Since plant-available N is probably lower in KIM because of greatly reduced inputs, N-uptake may also be lower (thus reduced %N in needles). Nitrogen may be concentrated in needles that are stressed (Stitt and Schulze 1994) due to, possibly, the toxic effects of aluminium on fine roots in the acid rain catchments.



**Figure 7.3** Comparison of element concentrations, contents per needle and  $\delta^{15}\text{N}$  values of *Pinus sylvestris* between the catchments in September 1992. Shown are mean values of 10 samples per tree with standard error bars. The concentrations of the cations are measured in  $\mu\text{mol}$  or  $\text{mmol}$  per g needle dry weight (dw) and (N) in  $\text{mmol}$  per g dry weight.



## Birch

As with pine needles, significantly higher concentrations of magnesium and potassium were found in birch leaves from the clean rain-roofed catchment (KIM) than acid rain-roofed catchment (EGIL), with the acid rain-open catchment (CECILIE) again intermediate (Figure 7.4). Concentrations of calcium in birch leaves were not significantly different among the catchments. Nitrogen concentrations were significantly different in all three treatments: highest in CECILIE, intermediate in KIM and lowest in EGIL.

## Understory

No significant differences were found in base cation status from either *Vaccinium* or *Calluna* among the three catchments (Table 7.3).

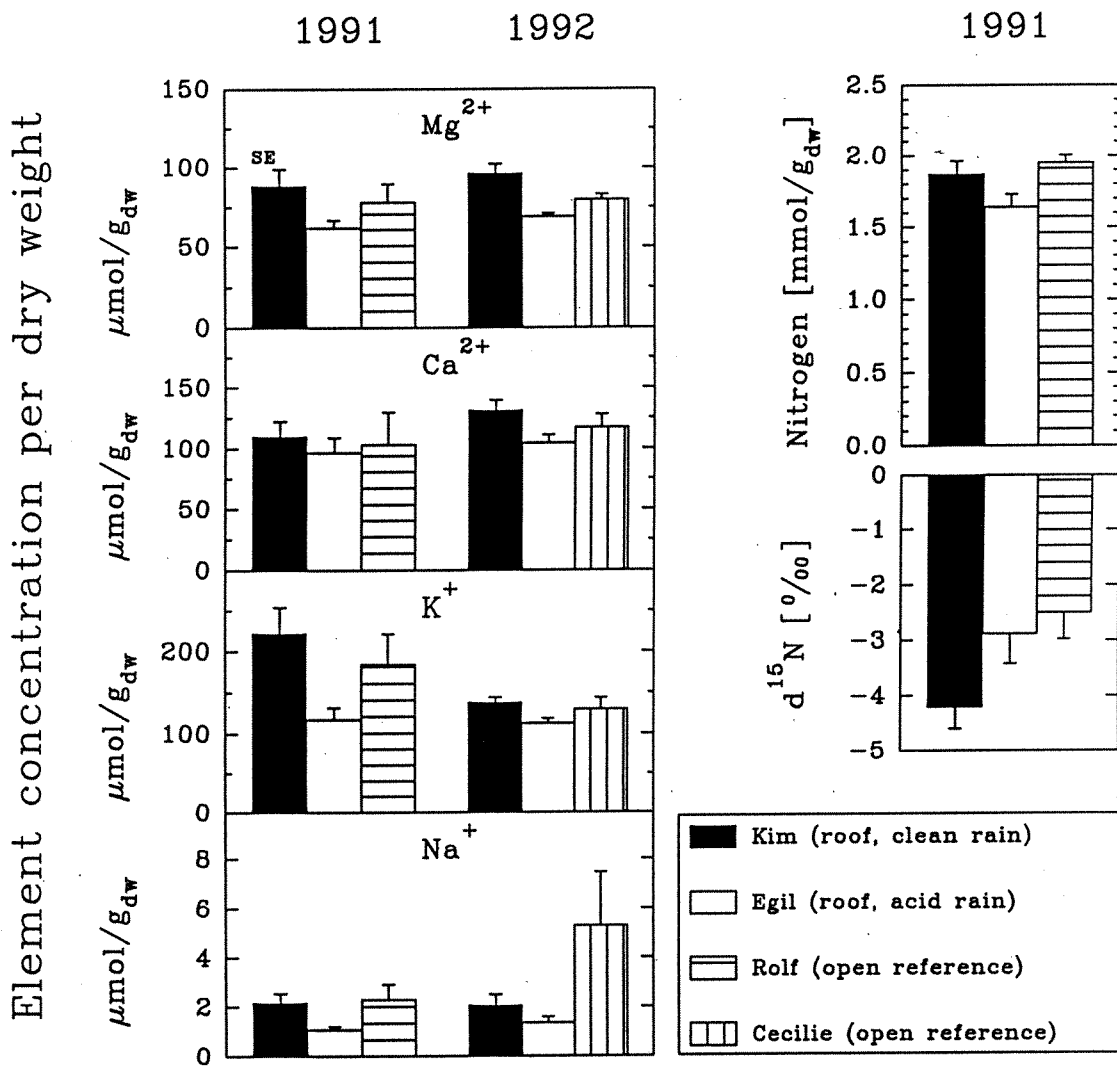
**Table 7.3** Nutrient data of *Vaccinium myrtillus* and *Calluna vulgaris* from August 1991. Element concentrations of cations are measured in  $\mu\text{mol per g}$  leaf dry weight and nitrogen in  $\text{mmol per g}$  dry weight. Natural isotope ratios of nitrogen ( $\delta^{15}\text{N}$ ) in ‰. ( $\pm$ ) one standard error in parentheses.

Species	n	Mg	Ca	K	Na	N	$\delta^{15}\text{N}$
<i>Vaccinium myrtillus</i>							
KIM	5	94.2 (10.5)	236 (20)	163 (11)	1.56 (0.3)	1.50 (0.05)	-4.48 (0.67)
EGIL	3	77.7 (11.0)	212 (3)	199 (24)	2.20 (1.20)	1.30 (0.10)	-2.80 (1.11)
ROLF	2	92.8 (3.2)	239 (0.8)	158 (22)	1.35 (0.05)	1.61 (0.09)	-3.56 (0.51)
<i>Calluna vulgaris</i>							
KIM	5	65.0 (1.7)	135 (7)	116 (7)	7.04 (1.87)	1.34 (0.08)	-5.43 (0.52)
EGIL	5	62.4 (3.6)	122 (13)	113 (11)	6.20 (1.44)	1.26 (0.04)	-5.06 (0.14)
ROLF	5	73.0 (4.0)	119 (5.7)	117 (7)	6.88 (1.71)	1.36 (0.04)	-6.94 (0.22)

## <sup>15</sup>N Isotopic Abundance

Preliminary results suggest that birch and pine in EGIL are slightly enriched in <sup>15</sup>N compared to the other catchments. Further work on <sup>15</sup>N is needed to detect any explicit trends.

*Betula pubescens*



**Figure 7.4** Element concentrations in *Betula pubescens* leaves in 1991 and 1992. Concentrations of cations are measured in μmol per g leaf dry weight, nitrogen concentrations (N) in mmol per g dry weight. Shown are mean values of 10 samples with standard error bars (SE). In 1991 data for the open reference were taken from the ROLF catchment, whereas in 1992 the samples are taken from the CECILIE catchment.

## Time Table

August 1994;

- sampling of needles and leaves for nutrient analysis
- sampling for soluble carbohydrates in needles
- biomedical measurements of twig and needle growth
- measurement of nitrate reductase

October 1994;

- sampling of needles and leaves for nutrient analysis
- sampling of soluble carbohydrates in needles.

## References

- Stitt, M. and Schulze, E-D. 1994. Plant growth, storage and resource allocation: From flux control in a metabolic chain to the whole plant level. In, Schulze, E-D. (Ed) Flux Control in Biological Systems; From Enzymes to Populations and Ecosystems. Academic Press, San Diego. pp 57 - 118.
- Thron, C. 1993. Auswirkungen der Bodenversauerung auf Wachstum und Nährstoff-Haushalt von *Pinus sylvestris* L. und *Betula pubescens* EHRH in Risdalsheia/Norwegen (Effects of soil acidification on the growth and element balance of *Pinus sylvestris* L. und *Betula pubescens* EHRH in Risdalsheia/Norway). MSc Thesis, Dept. of Biology, Ruprecht-Karl University, Heidelberg. 90 pp.

# Chapter 8

## *Ecophysiological Responses of Plants*

---

D.J. Beerling and F.I. Woodward

Department of Animal and Plant Sciences  
University of Sheffield  
PO Box 601  
Sheffield S10 2UQ  
U.K.

### Summary

The approach to characterising the ecophysiology of the plants in CLIMEX is to focus on plant attributes which have been shown by previous experimental data to be most sensitive to changes which the CLIMEX treatments will impose. These physiological attributes (photosynthesis, stomatal conductance,  $A/c_i$  responses, stomatal density and respiration rates) provide a benchmark of plant performance before treatments were imposed and against which future changes may be assessed. Greenhouse experiments provide some information on possible responses to the CLIMEX treatments of the *Vaccinium* shrubs, and permit some separation of the temperature and CO<sub>2</sub> effects. Experimental trials with controlled environments will continue in parallel with CLIMEX this year.

### 1. Introduction

This chapter sets out the background measurements of plant gas exchange made prior to the CLIMEX treatment of CO<sub>2</sub> enrichment and temperature increase. Due to the roof, vegetation within KIM has been exposed for the past eight years to altered environmental conditions, particularly spectral quantity and quality, which may have had a substantial impact on its functioning. For vegetation growing on acidic soils this feature (spectral quality and quantity) is most likely to exert a stronger effect than the clean rain treatment. We have considered some ecophysiological features of the dominant tree species *Pinus sylvestris* and *Betula pubescens* and the dwarf shrub *Vaccinium myrtillus* growing at Risdalsheia, southern Norway. Also present within KIM were two additional species of *Vaccinium*, *V. vitis-idaea* and *V. uliginosum*. These two species and *V. myrtillus* have distinct distributions in the United Kingdom, possibly controlled by innate differences in respiration rates (Stewart and Bannister 1973, 1974), and so are of particular interest in terms of their physiological responses to global change and the effect these responses may have on the present-day distributions of the species. Therefore these two *Vaccinium* species were also included in our collection of background data.

In addition to making measurements characterising the gas-exchange of the plants inside and outside the roof we have also performed several controlled environment experiments exposing *V. vitis-idaea* to CO<sub>2</sub> enrichment and elevated temperatures to predict possible

effects of the CLIMEX treatments on the *V. vitis-idaea*. Overall we had three specific aims: (i) to characterise the effects of the KIM enclosure on the gas exchange of the plants, (ii) to provide a set of background data against which comparisons may be made in future years after treatment and (iii) to predict possible gas-exchange responses of *V. vitis-idaea* to the proposed CLIMEX treatments using controlled environment experiments.

## 2. Materials and Methods

### *Sampling Strategy*

Before leaf gas exchange measurements were made, individual trees of *Betula pubescens* (N=15) and *Pinus sylvestris* (N=9) within KIM which had not yet reached the roof were tagged for identification and future measurements. Ten shoots of *V. myrtillus* plants were also tagged, together with 5 each of the less abundant *V. vitis-idaea* and *V. uliginosum*. Outside KIM in the control catchment METTE, 5 trees each of *B. pubescens* and *P. sylvestris* were tagged together with 5 shoots of *V. myrtillus*. This procedure ensured that sampling at a later date was replicated on the same individuals each time.

### *Gas-Exchange Measurements*

#### *Photosynthesis and stomatal conductance*

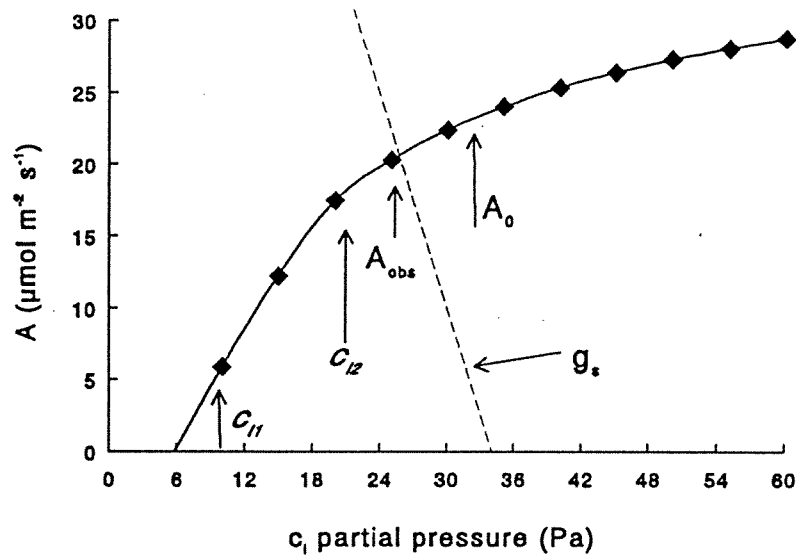
All gas-exchange measurements were made using a portable combined infra-red gas analyser (CIRAS-1) (P.P. Systems, Hitchin, Herts., UK). CIRAS-1 operates an open system where differences in CO<sub>2</sub> concentration and humidity entering and leaving a leaf chamber, as well as the system flow rate, are all measured and recorded (Long and Hällgren 1993). Photosynthetic rates ( $A$ ), stomatal conductance ( $g_s$ ) and intercellular CO<sub>2</sub> concentration were calculated from the equations of Farquhar et al. (1980).

Leaves of *B. pubescens* filled the entire window of the leaf chamber, whilst the leaf areas of *P. sylvestris* and the *Vaccinium* spp. were determined using a Delta-T leaf area meter (Cambridge, UK) in the laboratory. Temperature, humidity and irradiance used in the calculations were those prevailing at the time of the measurements. A deliberate effort was taken to make gas-exchange measurements only on clear, sunny days in full sunlight. Photosynthetically active radiation (PAR) (400-700nm) was recorded using the CIRAS-1 PAR sensor and leaf temperature estimates were made from the energy balance calculation. Using this system we attempted to obtain a time-series of data spanning a single day for each individual species, based on the individuals previously tagged. The results are considered as the means of these replicates.

#### *A/c<sub>i</sub> responses*

Single gas exchange measurements provide an instantaneous measure of the fluxes of CO<sub>2</sub> and H<sub>2</sub>O into and out of the leaf. The CIRAS-1 system is also capable of varying the CO<sub>2</sub> concentration within the leaf cuvette and thus the CO<sub>2</sub> concentration to which the leaf is exposed. This capability permits the construction of photosynthesis ( $A$ ) versus internal leaf CO<sub>2</sub> concentration ( $c_i$ ),  $A/c_i$  response curves. The  $A/c_i$  response (Figure 8.1) permits the separation of (i) stomatal from mesophyll limitations of photosynthesis (Farquhar and Sharkey 1982) and (ii) the limitations due to carboxylation rate and electron transport through the

## Typical $A/c_i$ response



**Figure 8.1** Typical  $A/c_i$  response, showing increasing intercellular  $\text{CO}_2$  concentration ( $c_i$ ) against net photosynthetic rate ( $A$ ). Values marked  $c_{i1}$  and  $c_{i2}$  correspond to the straight line portion of the plot and have been used to estimate  $V_{max}$ .  $A_{obs}$  and  $A_0$  are the photosynthetic rates with and without stomatal limitation.

mesophyll (Harley et al. 1992). Carboxylation rates are equivalent to the activity of active ribulose-1,5-biphosphate carboxylase-oxygenase ("rubisco"), described by the term  $V_{max}$ , whilst the rate of electron transport can be considered to be the light-dependent *rate* of regeneration of the  $\text{CO}_2$  acceptor molecule ribulose-bisphosphate (RuBP), described by  $J_{max}$ . At low  $c_i$  values the rate of photosynthesis is controlled by  $V_{max}$  (the activity of rubisco), whereas at high values of  $c_i$  the photosynthetic rate is controlled by  $J_{max}$  (the rate of RuBP regeneration) (Figure 8.1). Given that these two parameters exert fundamental control on the rate of photosynthesis we have constructed  $A/c_i$  response curves of the tree and shrub species inside and outside KIM to characterise possible difference in these variables.

The relative limitation ( $l$ ) imposed by stomata was calculated as:

$$l = \frac{A_0 - A_{obs}}{A_0} \quad (\text{Eq. 1})$$

where  $A_0$  is the photosynthetic rate assuming  $c_i = c_a$  (ambient  $\text{CO}_2$  or 350 ppm) (Figure 8.1) and  $A_{obs}$  is the observed photosynthetic rate (Farquhar and Sharkey 1982).

Calculation of  $V_{max}$  and  $J_{max}$  requires a mechanistic model of C3 photosynthesis. According to the Farquhar et al. (1980) model photosynthetic rates are determined by:

$$A = \left(1 - \frac{0.5O}{\tau c_i}\right) \min\{W_c, W_j\} - Rd \quad (\text{Eq. 2})$$

where  $O$  is the partial pressure of oxygen,  $c_i$  is the intercellular  $\text{CO}_2$  concentration,  $Rd$  is the daytime respiration,  $\tau$  is the specificity factor for rubisco,  $W_c$  is the rate of carboxylation limited by rubisco activity and  $W_j$  is the rate of carboxylation limited by electron transport.

When the rate of carboxylation is limited by rubisco activity, leaf photosynthesis is described by:

$$W_c = \frac{V_{\max} c_i}{c_i + K_c \left(1 + \frac{O}{K_o}\right)} \quad (\text{Eq. 3})$$

where  $K_c$  and  $K_o$  are the temperature dependent Michaelis-Menton constants for carboxylation and oxygenation (modelled using the temperature functions of McMurtrie and Wang 1993). When photosynthesis is limited by electron transport, the rate of carboxylation is given by:

$$W_j = \frac{Jc_i}{4\left(c_i + \frac{O}{\tau}\right)} \quad (\text{Eq. 4})$$

where  $J$  is the potential rate of electron transport, and the factor 4 indicates that 4 electrons are required to regenerate RuBP.  $J$  is dependent upon irradiance,  $I$  according to:

$$J = \frac{\alpha I}{\left(1 + \frac{\alpha^2 I^2}{J_{\max}^2}\right)^{0.5}} \quad (\text{Eq. 5})$$

where  $\alpha$  is the efficiency of light conversion (mol electrons/mol photons (0.24)). From this model Wullschleger (1993) reported the techniques for calculating  $V_{\max}$  and  $J_{\max}$  used in the present study.  $V_{\max}$  was calculated from the difference in photosynthetic rates between upper and lower values of  $A$  across the straight line portion of the  $A/c_i$  responses (determined visually), together with the difference between the two corresponding  $c_i$  values  $c_{i1}$  and  $c_{i2}$  (Figure 8.1). By combining equations 2 and 3 and using the  $A$  and the two  $c_i$  values derived from the  $A/c_i$  response,  $V_{\max}$  was determined from:

$$V_{\max} = \left[ \frac{\Delta A}{\frac{c_{i2}}{\left(c_{i2} + K_c + K_c \frac{O}{K_o}\right)} - \frac{0.5}{\left(c_{i2} + K_c + K_c \frac{O}{K_o}\right)} \frac{O}{\tau} - 1 \frac{c_{i1}}{\left(c_{i1} + K_c + K_c \frac{O}{K_o}\right)} + \frac{0.5}{\left(c_{i1} + K_c + K_c \frac{O}{K_o}\right)} \frac{O}{\tau}} \right] \quad (\text{Eq. 6})$$

$J_{\max}$  was first estimated using the empirical relationship between  $V_{\max}$  and  $J_{\max}$  reported by Wullschleger (1993). This estimation of  $J_{\max}$  was then used in equations 4 and 5, substituted

into equation 2, to calculate photosynthetic rates. Further estimation of  $J_{max}$  was then refined to produce photosynthetic rates which closely matched those observed at similar  $c_i$  values for the species in question.

In making estimates of  $V_{max}$  and  $J_{max}$  the model was parameterised using the values given by Wullschleger (1993) and Harley et al. (1992).

### *Stomatal densities*

Counts of stomatal density were made on two leaves each of *B. pubescens* and *V. myrtillus* using acetate replicas, and counting under low magnification.

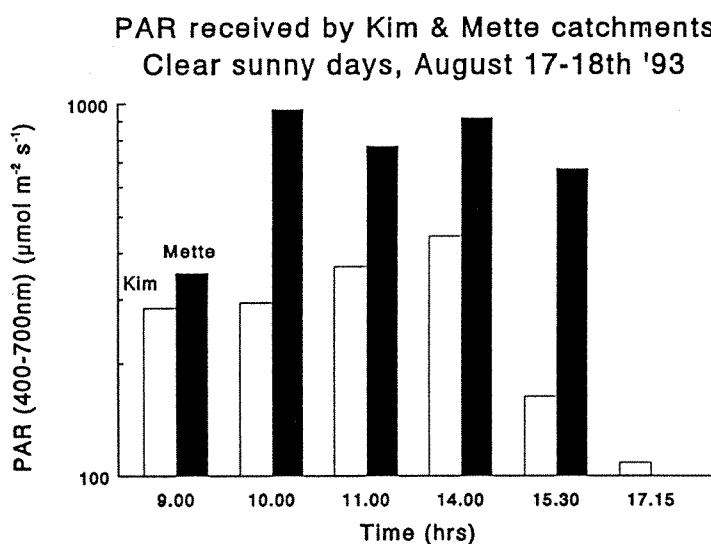
### *Greenhouse Experiments*

Facilities in the Department of Animal and Plant Sciences, University of Sheffield were used to investigate the possible photosynthetic responses of *V. vitis-idaea* to the CLIMEX treatments. These preliminary experiments provide some insights into responses of this and other species within the KIM enclosure when treatments begin.

We grew intact blocks ( $\frac{1}{4} \text{ m}^2 \times 10 \text{ cm}$ , ten replicates for each treatment) of *V. vitis-idaea* collected from the Sheffield area under three sets of environmental conditions for a period of three months:

1. Ambient  $\text{CO}_2$  and ambient temperature.
2. Elevated  $\text{CO}_2$  (+200 ppm above ambient) and elevated temperature (+ 10°C above ambient).
3. Ambient  $\text{CO}_2$  and elevated temperature (+10°C above ambient).

All blocks were regularly supplied with tap water. Gas exchange was periodically measured during the three months.  $A/c_i$  response curves were measured during the first month of treatment only (December) at saturating irradiance ( $700 \mu\text{mol m}^{-2} \text{ s}^{-1}$ ).



**Figure 8.2** Mean PAR values recorded by the CIRAS-1 IRGA for measurements made on plants during August in KIM and METTE catchments.



### 3. Results

#### *Microclimate*

In August 1993 plants growing inside KIM catchment received lower amounts of PAR than those growing outside in METTE, the control catchment (Figure 8.2). The combined data set for all species shows the difference was consistent throughout the day (Figure 8.2) and the results confirm measurements made by the permanent PAR sensors in KIM and METTE catchments (Chapter 2). Leaf temperatures of the two tree species *B. pubescens* and *P. sylvestris* and the dwarf shrub *V. myrtillus* were generally higher inside KIM than METTE, an effect which was particularly marked until mid-day (Figure 8.3).

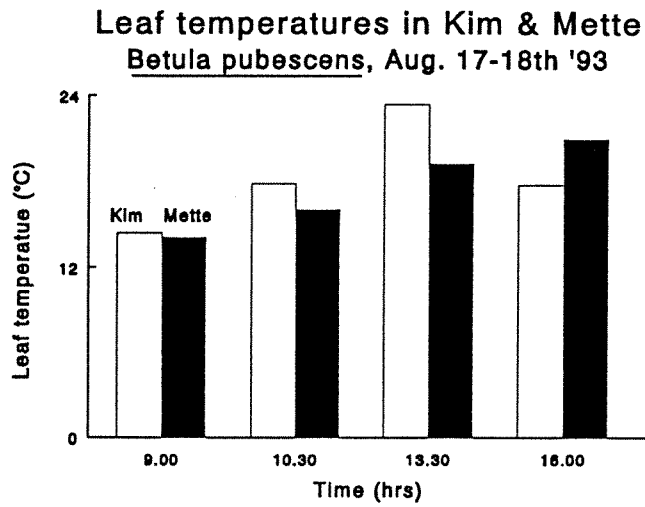
#### *Leaf Stomatal Conductance and Photosynthesis*

Time-series measurements of leaf stomatal conductance to water vapour showed consistent differences between plants growing under the KIM roof and plants outside in METTE. Under the roof the stomatal conductance was consistently lower for both the two tree species *B. pubescens* and *P. sylvestris* and the dwarf shrub *V. myrtillus* (Figs. 8.4a-c). The daily pattern of change was, however, fairly similar in plants growing inside and outside KIM. *B. pubescens* and *V. myrtillus* both exhibited classical mid-day stomatal closure (Figure 8.4a,c). In *B. pubescens* this effect was not observed for individuals growing in the control catchment METTE (Figure 8.4a). The conifer *P. sylvestris* showed no mid-day closure (Figure 8.4b), instead a general decline in stomatal conductance was observed during the course of the day until 14.00 hrs in both catchments.

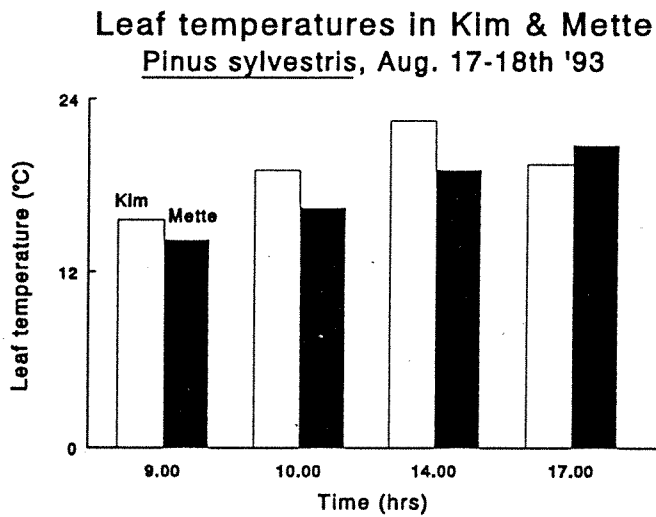
Photosynthetic patterns of the plants were considerably more variable and showed no consistent differences due to the roof (Figure 8.5a-c). A strong mid-day decline in photosynthetic rates of *B. pubescens* was observed in KIM whereas in METTE a gradual decline occurred until 16.00 hrs. The conifer *P. sylvestris* exhibited mid-day reductions in photosynthetic rates in both KIM and METTE but the timing of the reductions was out of phase, and rates were generally more reduced, under the roof (Figure 8.5b). The most marked effect of the KIM enclosure was a large reduction in the photosynthetic rates of *V. myrtillus* which were three times higher in METTE (Figure 8.5c).

Diurnal rates of photosynthesis declined in the order *V. uliginosum* > *V. vitis-idaea* > *V. myrtillus* (Figure 8.6). Overall photosynthetic rates declined in *V. uliginosum* and *V. vitis-idaea* during the day. No attempt was made to characterise the effects of the KIM roof on *V. uliginosum* and *V. vitis-idaea* since neither species is represented in the control catchment METTE. In addition to photosynthetic rates, measurements were also made of net gas exchange for twigs in each of the three *Vaccinium* species and for the *B. pubescens* growing within KIM catchment (Figure 8.7). The green photosynthetically-active stems of *V. myrtillus* show a net uptake of CO<sub>2</sub> as result of photosynthetic C fixation whereas those of the other two *Vaccinium* species show a drawdown of CO<sub>2</sub> through respiration.

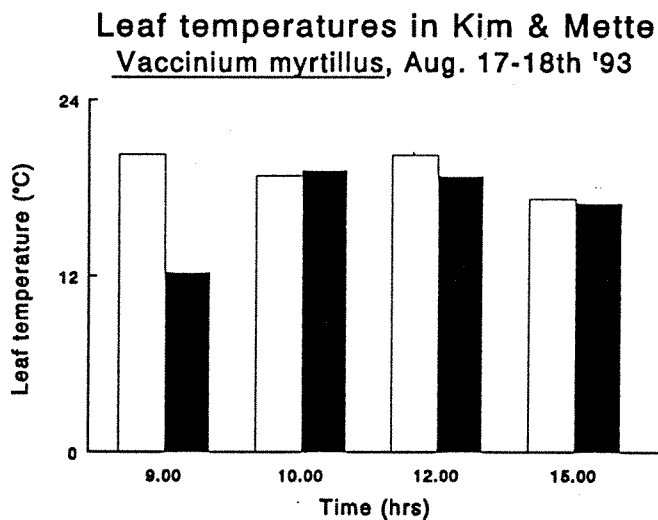
(a)



(b)

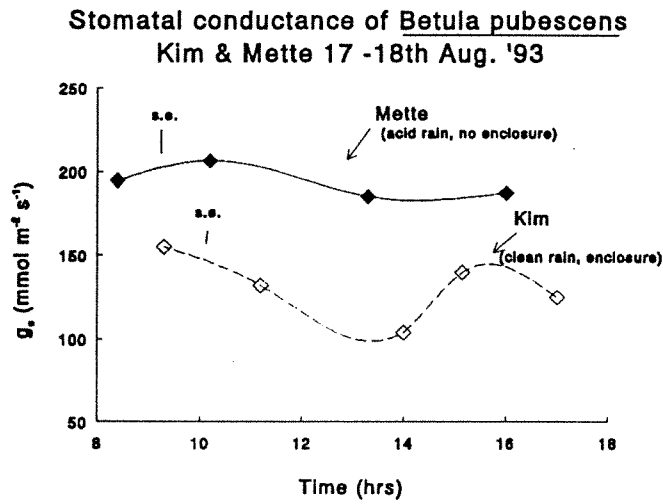


(c)

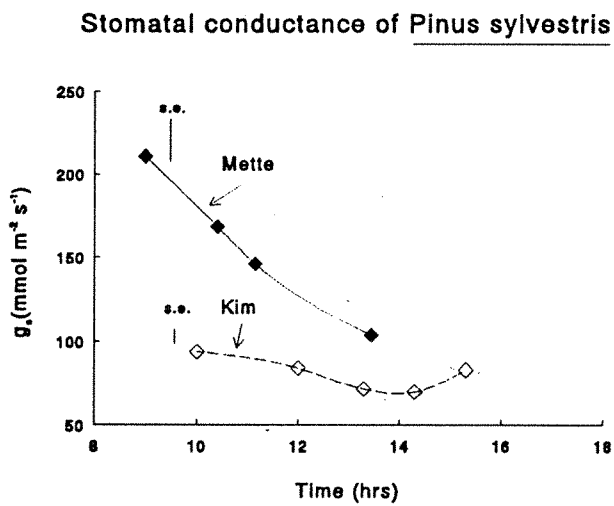


**Figure 8.3** Mean leaf temperatures, calculated using the energy balance equation, for leaves in KIM and METTE catchments for (a) *Betula pubescens*, (b) *Pinus sylvestris* and (c) *Vaccinium myrtillus*.

(a)



(b)



(c)

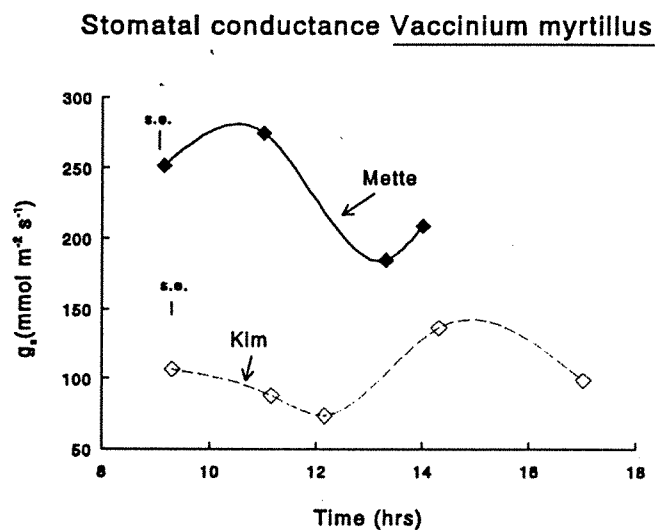
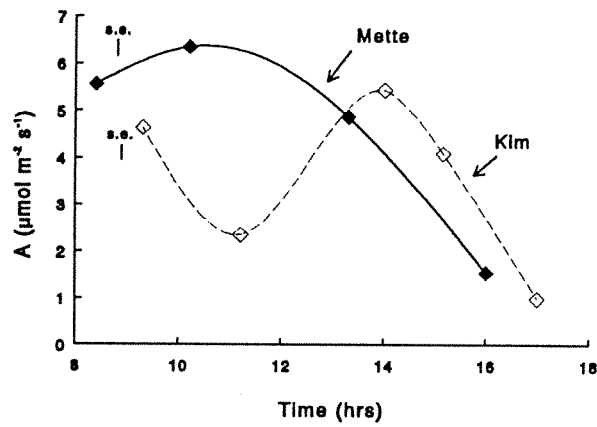


Figure 8.4 Daily course of the mean stomatal conductance ( $g_s$ ) of (a) *Betula pubescens*, (b) *Pinus sylvestris* and (c) *Vaccinium myrtillus* measured in KIM and METTE catchments.

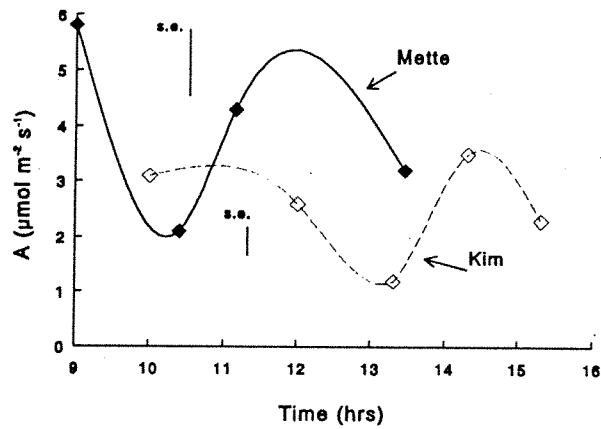
(a)

Photosynthesis of Betula pubescens  
Kim & Mette 17 -18th Aug. '93



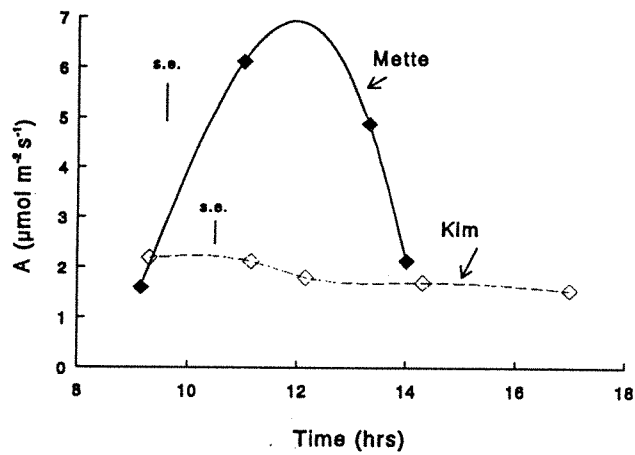
(b)

Photosynthesis of Pinus sylvestris



(c)

Photosynthesis of Vaccinium myrtillus



**Figure 8.5** Daily course of mean net photosynthetic rates (*A*) of (a) *Betula pubescens*, (b) *Pinus sylvestris* and (c) *Vaccinium myrtillus* measured in KIM and METTE catchments.

### *A/c<sub>i</sub> Response Curves and Associated Properties*

Whereas there were no large differences in  $A/c_i$  response curves between KIM and METTE for *B. pubescens* or *P. sylvestris* (Figure 8.8a-b), there was a marked reduction in photosynthetic rates for *V. myrtillus* plants growing in KIM (Figure 8.8c). Comparison of the  $A/c_i$  responses of each of the *Vaccinium* species (Figure 8.9) shows an order of photosynthetic rates consistent with that expected from the photosynthesis measurements (Table 8.1). The lower stomatal conductances of *P. sylvestris* and *V. myrtillus* growing in KIM compared to METTE imposed a higher stomatal limitation on photosynthesis (Table 8.1) (but not for *B. pubescens*). Plants growing in KIM had consistently higher  $V_{max}$  values than those growing outside the roof. In contrast, there was no pattern for  $J_{max}$  values for plants growing in KIM and METTE.  $V_{max}$  values for the three species of *Vaccinium* decreased in the order *V. myrtillus* > *V. uliginosum* > *V. vitis-idaea*.  $J_{max}$  values of *V. myrtillus* and *V. uliginosum* were similar and above those for *V. vitis-idaea*.

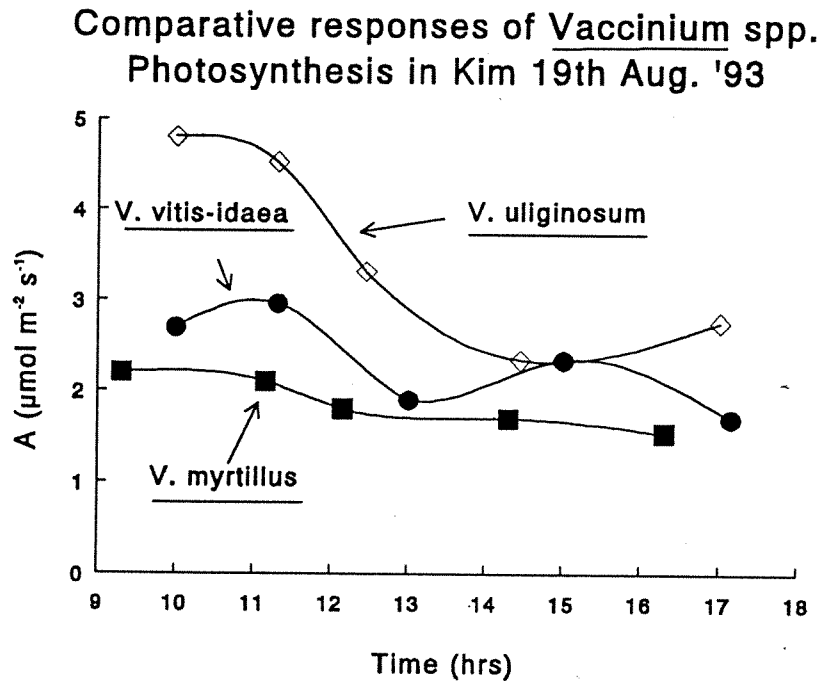
**Table 8.1** Characteristics of  $A/c_i$  responses of plants growing in Kim and Mette catchments during August 1993.  $V_{max}$  and  $J_{max}$  in  $\mu\text{mol m}^{-2} \text{s}^{-1}$ .

Species	Stomatal limitation (%)	Leaf temperature (°C)	$V_{max}$	$J_{max}$	$V_{max}$	$J_{max}$
			ambient		25°C	
<i>B. pubescens</i>						
KIM	16.5	28.9	68.9	102.0	57.9	90.3
METTE	20.4	23.4	32.8	82.9	35.7	89.0
<i>P. sylvestris</i>						
KIM	15.1	22.1	33.2	51.0	38.9	58.6
METTE	13.8	21.9	23.1	54.0	27.4	62.7
<i>V. myrtillus</i>						
KIM	15.0	24.6	53.6	60.0	54.7	61.0
METTE	14.7	25.8	49.2	105.4	47.3	102.1
<i>V. uliginosum</i>						
KIM	21.7	26.2	28.5	65.0	26.9	62.1
<i>V. vitis-idaea</i>						
KIM	21.7	27.0	26.1	55.0	23.7	51.2

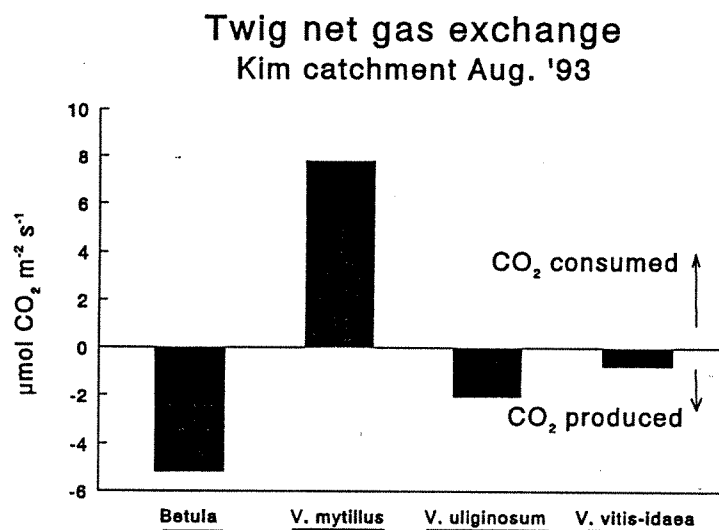
### *Controlled Environment Experiments*

*V. vitis-idaea* plants growing in elevated  $\text{CO}_2$  and temperature showed a progressive decline in photosynthetic rate during the three-month growth period (Figure 8.10). Elevated temperature in itself did not significantly increase photosynthetic rates relative to the control

(Figure 8.10).  $A/c_i$  response curves constructed for plants growing under the different treatments show a clear combined effect of elevated  $\text{CO}_2$  and temperature on photosynthetic rates (Figure 8.11), with these plants also having the highest values of  $V_{max}$  and  $J_{max}$  (Table 8.2). At saturating irradiance, increased temperatures had a similar effect at saturating irradiance, increasing photosynthetic rates relative to the controls in December (Figure 8.10).



**Figure 8.6** Comparative changes in photosynthesis during the day for three species *Vaccinium* growing within KIM catchment.



**Figure 8.7** Net twig respiration rates, measured in the light, for three species of *Vaccinium* and *B. pubescens* growing in KIM catchment. Note the net draw-down of  $\text{CO}_2$  by the green stems of *V. myrtillus*.

**Table 8.2** Characteristics of  $A/c_i$  responses of *Vaccinium vitis-idaea* growing under different experimental treatments in greenhouses at Sheffield, U.K.  $V_{\max}$  and  $J_{\max}$  in  $\mu\text{mol m}^{-2} \text{s}^{-1}$ .

Treatment	Stomatal limitation (%)	Leaf temperature (°C)	$V_{\max}$	$J_{\max}$	$V_{\max}$	$J_{\max}$
			ambient		25°C	
Ambient CO <sub>2</sub> Ambient temperature	16.7	7.8	8.6	6.6	18.3	20.6
Ambient CO <sub>2</sub> Elevated temperature (ambient + 10 °C)	11.6	18.4	13.5	28.0	19.9	40.7
Elevated CO <sub>2</sub> (ambient + 200 ppm) Elevated temperature (ambient + 10 °C)	7.5	20.0	18.7	33.0	24.9	42.9

#### 4. Discussion

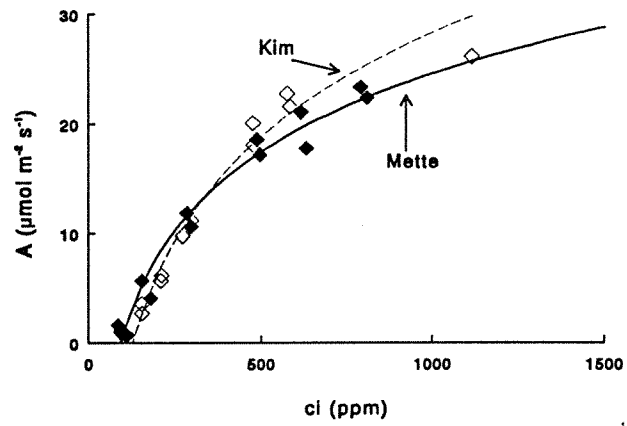
##### *Gas Exchange of Plants in KIM and METTE*

The most apparent effects of the roof in KIM catchment is a ca. 50% reduction in the quantity of PAR received by the vegetation underneath the roof between April and August (Jenkins and Wright 1992) and the re-radiation of heat from the roof back to the vegetation on clear sunny days. The latter effect generally increased the leaf temperatures of *B. pubescens* and *P. sylvestris* in KIM above those of plants growing in METTE (Figure 8.3a-c). Vertical temperature profiles to be measured on tall individuals of *B. pubescens* and *P. sylvestris* in the coming growing season will help to quantify this effect.

Irradiance and temperature are two important environmental factors affecting the stomatal conductance of plants (Jones 1993). Ng and Jarvis (1980) reported a marked decline in the stomatal conductance of *P. sylvestris* with decreasing PAR, particularly between 200 and 1000  $\text{mol m}^{-2} \text{s}^{-1}$ , values typically recorded in KIM and METTE respectively (Figure 8.2). Temperature effects on stomatal conductance are more complicated and closely linked to other aspects of the environment, especially humidity and the water status of the plant and soil, all of which will be monitored in KIM and METTE in the forthcoming growing season. In *V. myrtillus* the lower conductances may also be partly attributable to lower stomatal densities of plants within KIM (mean densities on the lower leaf surface 160  $\text{mm}^{-2}$  and 220  $\text{mm}^{-2}$  in KIM and METTE, respectively).

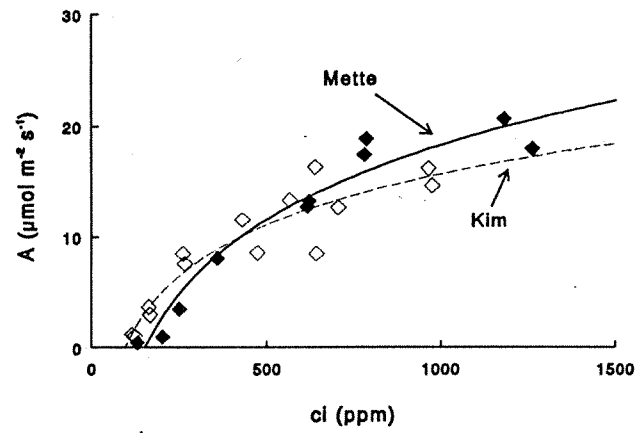
(a)

CLIMEX  $A/c_i$  responses, August '93  
Betula pubescens



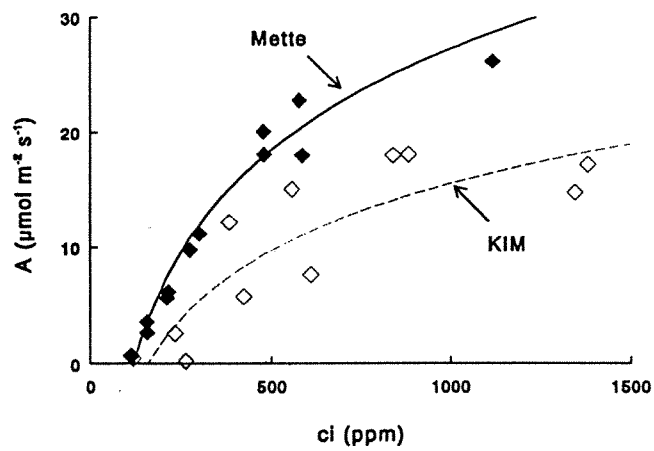
(b)

Pinus sylvestris



(c)

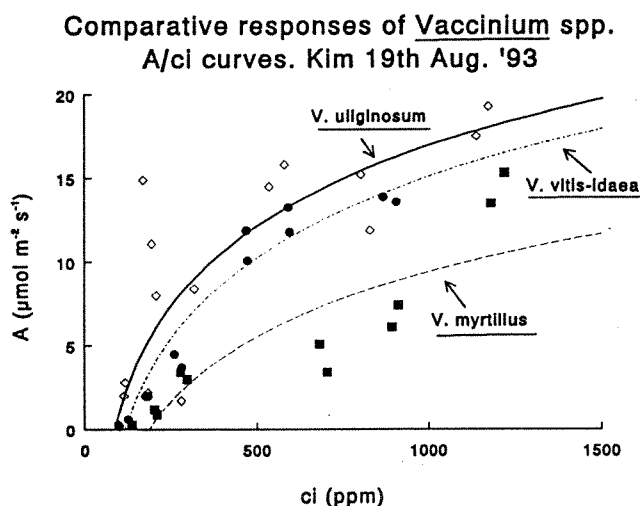
Vaccinium myrtillus



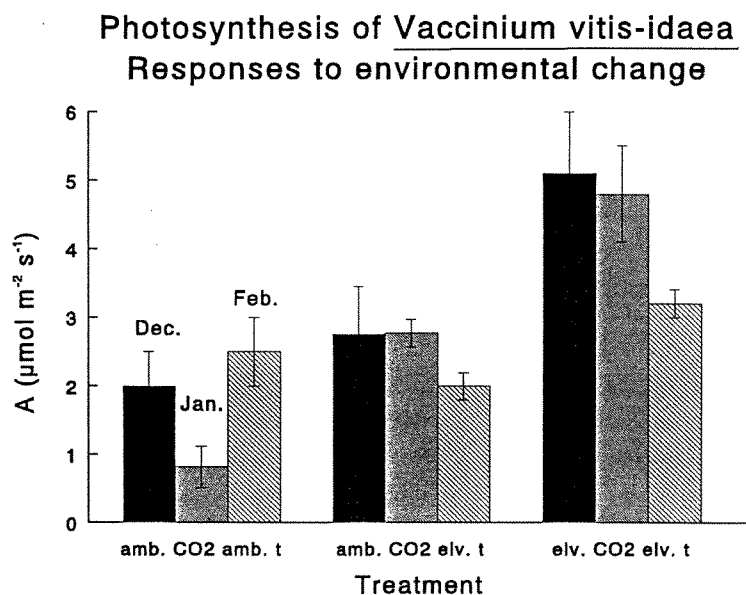
**Figure 8.8**  $A/c_i$  response curves of (a) *B. pubescens*, (b) *P. sylvestris* and (c) *V. myrtillus* measured in KIM and METTE catchments.



Overall the roof did not greatly influence the photosynthetic rates of the trees growing under it, despite its effect on stomatal conductance. Daily patterns of both stomatal conductance and photosynthesis for both sets of *P. sylvestris* trees investigated (Figures 8.4b and 8.5b) are typical for the time of year (Beadle et al. 1985). That photosynthesis of *V. myrtillus* was most affected by the environmental conditions within the enclosure (Figure 8.5c) was surprising given it frequently occurs as an understory shrub in *P. sylvestris* woodland receiving low light levels (Ritchie 1956) and that it showed no marked differences in leaf temperature between KIM and METTE catchments (Figure 8.3c). The photosynthetic rates recorded for *V. myrtillus* in METTE appear to be more typical of this species (Woodward 1986). One explanation may be differences in soil moisture: the thin soils in which *V. myrtillus* grows in KIM tend to dry out quickly relative to the deeper soils in METTE.

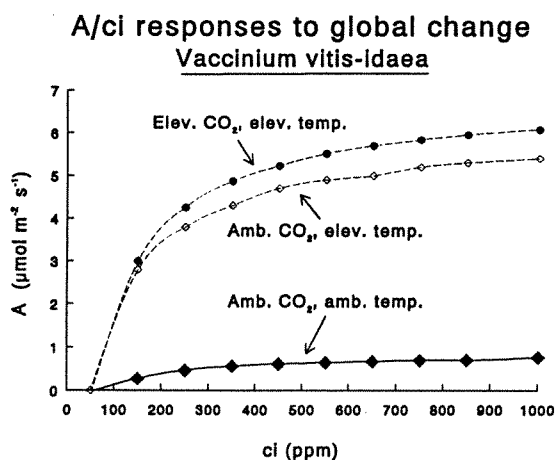


**Figure 8.9** Comparison of  $A/c_i$  responses curves for three species of *Vaccinium* growing in KIM catchment.



**Figure 8.10** Effects increased temperature (+10 °C above ambient) and increased CO<sub>2</sub> (+200 ppm above ambient) and temperature (+10 °C above ambient) on photosynthetic rates of *Vaccinium vitis-idaea* after one (Dec.), two (Jan.) and three months (Feb.) exposure. Values are mean  $\pm$  1 s.e.

Analysis of the amount and activity of rubisco ( $V_{max}$ ) and the rate of electron transport ( $J_{max}$ ) derived from the  $A/c_i$  response curves permit a consideration of the roof effect at the biochemical level of the leaves (Wullschelger 1993). Plants growing in KIM had higher  $V_{max}$  values than those growing in METTE, indicating increased amounts and activity of rubisco and providing some evidence of acclimatization to the lower light levels of KIM for all three species.



**Figure 8.11** Effects of different treatments on the  $A/c_i$  responses of *V. vitis-idaea*. Curves were constructed using the Harley et al. (1992) photosynthesis model, parameterised for  $V_{max}$ ,  $J_{max}$ , irradiance and leaf temperature using the measured values.

### Greenhouse Experiments

Increases in  $CO_2$  and temperature stimulated the photosynthetic rate of *V. vitis-idaea* relative to the control plants (Figure 8.10), as suggested by previous modelling studies (Beerling and Woodward 1993; Long 1991) and experimental investigations on other species (Mitchell et al. 1993; Ryle et al. 1992). The observed decline in photosynthetic rate over the three-month period of the experiment may have been due to several factors including constrained root growth as a result of pot size (Arp 1991), end-product inhibition or some degree of acclimation occurring at the biochemical level (Eamus and Jarvis 1989). Whether the downward adjustment of photosynthetic rates of *V. vitis-idaea* observed in this experiment occur within KIM after the treatment has been imposed remain to be seen. There is at present some discrepancy between results reported from long-term exposure to elevated  $CO_2$  from pot-based studies on individual plants and those from *in situ* field situations (Beerling and Woodward 1993; Long 1991). Some of these differences may be attributable to differences in nutrient availability between the different ecosystems studied, but a better understanding will only be achieved by further experimental work on ecosystems in combination with careful reductionist experiments.

## 5. References

- Arp, W.J. 1991. Effects of source sink relations on photosynthetic acclimation to elevated  $CO_2$ . *Plant, Cell and Environment* 14: 869-875.

- Beadle, C.L., Neilson, R.E., Talbot, H. and Jarvis, P.G. 1985. Stomatal conductance and photosynthesis in mature Scots pine forest. I. Diurnal, seasonal and spatial variation in shoots. *Journal of Applied Ecology* 22: 557-571.
- Beerling, D.J. and Woodward, F.I. 1993. The climate change experiment (CLIMEX): phenology and gas exchange responses of boreal vegetation to global change. *Global Ecology and Biogeography Letters*, in press.
- Eamus, D. and Jarvis, P.G. 1989. The direct effects of increase in the global atmospheric CO<sub>2</sub> concentration on natural and commercial temperate trees and forests. *Advances in Ecological Research* 19: 1-55.
- Farquhar, G.D., von Caemmerer S. and Berry, J.A. 1980. A biochemical model of photosynthetic CO<sub>2</sub> assimilation in leaves of C3 plants. *Planta* 149: 78-90.
- Farquhar, G.D. and Sharkey, T.D. 1982. Stomatal conductance and photosynthesis. *Annual Review of Plant Physiology* 33: 317-345.
- Harley, P.C., Thomas, R.B., Reynolds, J.F. and Strain, B.R. 1992. Modelling the photosynthesis of cotton grown in elevated CO<sub>2</sub>. *Plant, Cell and Environment* 15: 271-282.
- Jenkins, A.J. and Wright, R.F. 1992. The "CLIMEX" project - raising CO<sub>2</sub> and temperature to the whole catchment ecosystems. Workshop on Design and Execution of Experiments on CO<sub>2</sub> Enrichment, Weidenberg, Germany, October 1992.
- Jones, H.G. 1993. *Plants and Microclimate: A Quantitative Approach to Environmental Plant Physiology* (2nd Ed.). Cambridge University Press, Cambridge.
- Long, S.P. 1991. Modification of the response of photosynthetic productivity to rising temperatures by atmospheric CO<sub>2</sub> concentration: has its importance been underestimated? *Plant, Cell and Environment* 14: 729-739.
- Long, S.P. and Hällgren, J-E. 1993. Measurement of CO<sub>2</sub> assimilation by plants in the field and the laboratory. In: Hall, D.O., Scurlock, J.M.O., Bolhar-Nordenkamp, H.R., Leegood, R.C. Long, S.P. (Eds.), *Photosynthesis and Production in a Changing Environment: A Field and Laboratory Manual*, pp. 129-167. Chapman and Hall, London.
- McMurtrie, R.E. and Wang, Y.P. 1993. Mathematical models of the photosynthetic responses of tree stands to rising CO<sub>2</sub> concentrations and temperatures. *Plant, Cell and Environment* 16: 1-13.
- Mitchell, R.A.C., Mitchell, V.J., Driscoll, S.P., Franklin, J. and Lawlor, D.E. 1993. Effects of increased CO<sub>2</sub> and temperature on growth and yield of winter wheat at two levels of nitrogen application. *Plant, Cell and Environment* 16: 521-529.
- Ng, P.A.P. and Jarvis, P.G. 1980. Hysteresis in the response of stomatal conductance in *Pinus sylvestris* L. needles to light: observations and a hypothesis. *Plant, Cell and Environment* 3: 207-216.

- Ritchie, J.C. 1956. Biological Flora of the British Isles: *Vaccinium myrtillus* L. Journal of Ecology 44: 291-299.
- Ryle, G.J.A., Powell, C.E. and Davidson, I.A. 1992. Growth of clover, dependent upon N<sub>2</sub> fixation, in elevated CO<sub>2</sub> and temperature. Annals of Botany 70: 221-228.
- Stewart, W.S. and Bannister, P. 1973. Seasonal changes in carbohydrate content of three *Vaccinium* spp. with particular reference to *V. uliginosum* L. and its distribution in the British Isles. Flora 162: 134-155.
- Stewart, W.S. and Bannister, P. 1974. Dark respiration rates in *Vaccinium* spp. in relation to altitude. Flora 163: 415-421.
- Woodward, F.I. 1986. Ecophysiological studies on the shrub *Vaccinium myrtillus* L. taken from a wide altitudinal range. Oecologia 70: 580-586.
- Wullschlegel S.D. 1993. Biochemical limitations to carbon assimilation in C3 plants - a retrospective analysis of the A/c<sub>i</sub> curves from 109 species. Journal of Experimental Botany 44: 907-920.

# Chapter 9

## *Soil Fauna*

---

M. J. Vreeken-Buijs<sup>1</sup> and L. Brussaard<sup>1,2</sup>

<sup>1</sup>DLO Research Institute for Agrobiological and Soil Fertility (AB-DLO)

P.O. Box 129

NL-9750 AC Haren

The Netherlands

<sup>2</sup>present address:

Department of Terrestrial Ecology and Nature Conservation

Wageningen Agricultural University

Bornsesteeg 69

NL-6708 PD Wageningen

The Netherlands

### **Summary**

Three different experiments have been started using birch litter grown under conditions of elevated- versus ambient-CO<sub>2</sub> and clean- versus ambient-precipitation. The raised CO<sub>2</sub> level resulted in a higher C:N ratio of the litter. The experiments are: (1) a litterbag experiment which uses different mesh sizes to study the effect of microarthropods on the decomposition of litter in the four different catchments by means of exclusion, (2) a mesocosm experiment which uses defaunated versus refaunated soil and litter to study the effect of microarthropods on the breakdown and mineralization of litter under eight different climatic treatments (combinations of changed CO<sub>2</sub>, temperature and precipitation) and (3) a plant uptake experiment which uses birch trees in pots with defaunated and refaunated soil and litter to study the effect of microarthropods on the uptake of nutrients under eight different climatic treatments in a greenhouse.

Pilot studies have revealed that: 1) average microarthropod density (0-10 cm depth) was 619,000/m<sup>2</sup> in the KIM catchment and 436,000/m<sup>2</sup> outside, 2) freezing at -40°C is a more effective method for defaunation of soil than oven-drying and also minimizes soil chemical changes and 3) the presence of predatory mites in a mesocosm is essential to prevent population explosions of fast-reproducing microbivorous mites.

### **1. Introduction**

The effect of soil fauna on the decomposition of litter and the mineralization of nutrients can vary greatly depending on, for example, the quality of the organic substrate (Verhoef and Brussaard 1990). It is well documented that an increase in atmospheric CO<sub>2</sub> can lead to a relative decrease in the nitrogen content of the litter (Eamus and Jarvis 1989), to changes in the structure and density of the leaf tissue (Thomas and Harvey 1983, Radoglov and Jarvis

1990, Lemon 1983) and to an increase in the level of phenolic substances in the leaves (Jonasson et al. 1986, Laine and Hettonen 1987). These factors all influence the activity and the composition of the microbial population (Luxmore 1981). Although they generally stimulate decomposition through their role in physically breaking down organic matter, soil mesofauna may also indirectly inhibit decomposition by excessive grazing on primary decomposers (e.g. fungi, bacteria) (Coleman et al. 1983). Such impacts of the soil fauna at the ecosystem level have received insufficient attention.

A diverse soil fauna community was shown to stimulate decomposition of litter of chestnut (*Castanea*), beech (*Fagus*) and birch (*Betula*) (Anderson 1973, Setälä et al. 1990, Huhta and Setälä 1990, Setälä et al. 1991) and to stimulate the uptake of nutrients by birch seedlings (Setälä and Huhta 1991). These effects can be modified, however, as the quality of the litter changes under changing atmospheric conditions. Coûteaux et al (1991) studied the influence of different levels of complexity in the soil fauna community on the decomposition and mineralization of sweet chestnut (*Castanea sativa*) litter grown at two different CO<sub>2</sub> levels. As expected, increased community diversity stimulated decomposition and increased CO<sub>2</sub> appeared to inhibit decomposition (through increasing the C/N ratio of the litter). However, the enhancing effect of community diversity was most pronounced in the high-CO<sub>2</sub> litter (with a relatively low initial nitrogen content). In the microcosms with the most complex faunal community the decomposition rate of the high-CO<sub>2</sub> litter approximated the decomposition rate of the ambient-CO<sub>2</sub> litter, while in the latter the complexity of the soil fauna had no significant effect on decomposition rates. These results indicate an increasing importance of the soil fauna at higher atmospheric CO<sub>2</sub> levels.

The most complex system used in the experiment of Coûteaux et al. (1991) did not include predatory species. Longer experiments without these species may lead to population explosions of collembola and microbivorous mites (Vreeken-Buijs, in prep.) and nematodes (Santos and Whitford 1981, Setälä et al. 1991) which in turn may lead to overgrazing of the microbial population and inhibition of decomposition. There is a need, therefore, to establish the effect of a complete soil fauna community, including predators, on decomposition rates of litter grown under different CO<sub>2</sub> levels.

The low average temperature of southern Norway makes realistic decomposition experiments necessarily long-term experiments. Therefore, we chose to conduct a two-year litterbag field experiment and two different two-year laboratory experiments comparing a system without mites and collembola to one with a microarthropod community representative of the complete microarthropod community of the Risdalsheia soil. As opposed to the controlled systems used by Coûteaux et al. (1991) we chose to work in the greenhouse with a species composition in which the meso- and microfauna is not controlled, but resembles as much as possible the natural composition. The field litterbag experiment can be compared to lab results and also gives us the opportunity to monitor any qualitative or quantitative changes in the species composition of microarthropods as a result of the climate change treatment. During 1993 detailed plans and preparations were made for the three main experiments which started in May 1994. We present here the experimental setup used in the field and laboratory in CLIMEX and the results of the first year pilot studies.

## 2. Methods

### *Field Experiments*

#### *Litterbags*

The aims of the litterbag study are:

1. To identify the differences, if any, in soil fauna between the different treatments.
2. To identify the differences, if any, in litter decomposition rate between the treatments.
3. To study the effect of the soil mesofauna on litter decomposition rate under the different treatments.
4. To study the changes in the chemical composition of the decomposing litter with and without soil mesofauna under the different treatments.

Litterbags (15 x 15 cm) were filled with 4 g (dry matter) *Betula pubescens* (birch) litter which was grown in the laboratory under conditions corresponding to the CLIMEX treatments (Table 9.1). The same litterbags are also used in the decomposition study (Chapter 5). Half of the bags have a mesh size of 1.5 mm and half have a mesh size of 40 µm to exclude soil macro- and mesofauna, respectively (Anderson 1973). This results in the following experimental setup:

4	treatments (field plots)
<u>x2</u>	mesh sizes
8	
<u>x10</u>	internal replicates
80	
<u>x6</u>	sampling dates (0,6,12,18 and 24 months)
480	litterbags

**Table 9.1** Laboratory growth conditions of *Betula pubescens* litter used in litterbag experiment.

Treatment	CO <sub>2</sub>	Temperature	Precipitation
"KIM1"	ambient	ambient	clean
"KIM2"	raised	raised	clean
"EGIL1"	ambient	ambient	ambient
"EGIL2"	ambient	raised	ambient

All litterbags were defaunated by freezing (-40°C, 2x48 hr), then placed in the catchment corresponding to the initial laboratory treatment in April 1994 (month 0 of sampling scheme). Litterbags will be sampled every six months, at the end of summer and the end of winter. After sampling, the weight loss, loss of nutrients (N and P), C:N ratio and lignin:N ratio of the litter will be assessed and microarthropods, nematodes and enchytraeids will be counted, subdivided by functional groups.

### *Field survey*

In preparation for the litterbag study the Risdalsheia field site was visited in September 1993. Undisturbed soil samples (diameter 6 cm, depth 10 cm) were collected for microarthropod extraction, two in the KIM catchment and three replicates from each of four different catchments with similar vegetation outside. In another catchment, traps containing 4% formaldehyde solution were placed in pits for one night to capture macroarthropods. Nematodes and enchytraeids were extracted from mixed soil samples using the wet Tullgren extraction method.

### *Laboratory Experiments*

#### *Soil fauna mesocosms*

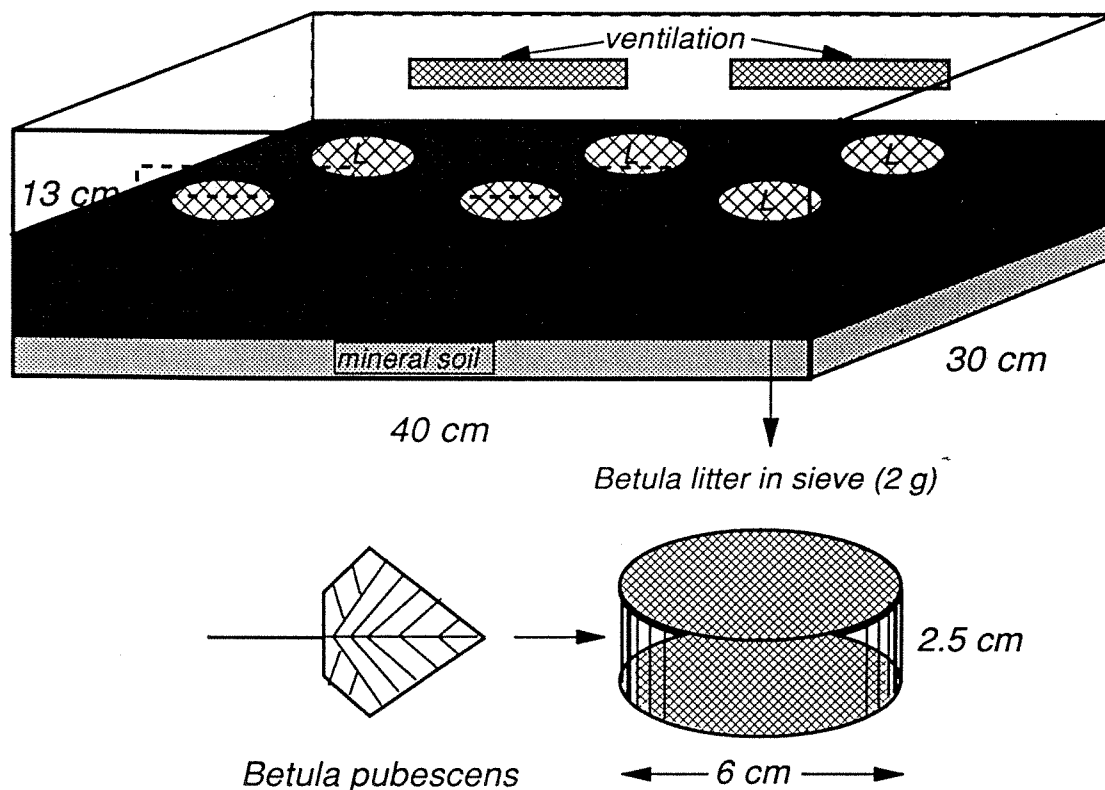
The aim of the mesocosm experiment is to study the effect of the complete soil fauna community (including the soil mesofauna) on the decomposition and nutrient release of birch litter under controlled laboratory conditions (Huhta and Setälä 1990). Hard polyethylene boxes (30 x 40 x 13 cm) were filled with a layer of washed sand, separated by a mesh screen and covered with a layer of humus to mimic the soil at the field sites (Figure 9.1). The same *Betula* litter (2 g dry weight) as used in the litterbags (Table 9.1) was packed in 6 cm diameter sieves, the bottoms of which are covered with 1.5 mm gauze. The sieves were inserted into holes in the humus, with six sieves ("microcosms") per box ("mesocosm"). The boxes were partially sterilized by freezing (-40°C, 2x48 hr). Half of the boxes were reinoculated with microarthropods extracted from soil collected from the field site (Tullgren apparatus).

**Table 9.2** Laboratory conditions of the mesocosms and the plant uptake experiment.

Treatment #	CO <sub>2</sub> (ppm)	Temperature	Precipitation
1.	350	ambient	clean
2.	350	ambient	ambient
3.	350	summer: +2°C; winter: +6°C	clean
4.	350	summer: +2°C; winter: +6°C	ambient
5.	700	ambient	clean
6.	700	ambient	ambient
7.	700	summer: +2°C; winter: +6°C	clean
8.	700	summer: +2°C; winter: +6°C	ambient



The transfer occurs in several phases until a volume of soil has been extracted that exceeds the soil volume of the mesocosm so as to compensate for mortality due to the procedure. The boxes are closed with a lid and have ventilation holes covered with mesh screen at the sides above the soil surface level. They are incubated under eight different climate conditions (Table 9.2).



**Figure 9.1** Schematic representation of a mesocosm.

During the incubation the sieves will be taken out every three months and leached with 40 ml demineralized water in mini-lysimeters. The leachate will be analyzed for  $\text{NO}_3^-$ -N,  $\text{NH}_4^+$ -N, P, pH and numbers of nematodes. Soil moisture will be monitored by weight and "clean" or "ambient" water will be added as necessary.

Every six months three replicates of every treatment will be destructively sampled and analyzed for weight loss of the litter, fauna content of litter and humus, KCl-extractable N and P of litter and humus, and C:N and lignin:N ratio of the litter. This results in the following experimental setup:

8	climate treatments
<u>x3</u>	mesocosm replicates
24	
<u>x2</u>	fauna treatments (+ and -)
48	
<u>x5</u>	sampling dates (0, 6, 12, 18, 24 months)
240	mesocosms (boxes)
<u>x6</u>	
1440	microcosms (sieves)

This experiment was started in June 1994 (month 0 of sampling).

## *Plant nutrient uptake*

The aim of the nutrient uptake experiment is to study the effect of the soil mesofauna on the uptake of N and P from litter by birch seedlings under controlled laboratory conditions (Setälä and Huhta 1991).

Plastic pots (18 cm diameter) were filled with 2 cm of washed sand, 4 litres substrate and *Betula* litter (5 g dry weight). The pots are partially sterilized by freezing (see mesocosm experiment), after which half are reinoculated with microarthropods. One-year old 10-cm high *Betula* seedlings, defaunated by chloroform fumigation (1 hour), were planted in the pots and incubated under the same eight climate conditions as used in the mesocosm experiment (Table 9.2). Soil moisture content is checked by tensiometers and maintained as necessary. Every six months the N and P content of the soil solution will be measured.

After destructive sampling dry mass and N, P and lignin content of the leaves, stem and roots will be assessed, as well as dry mass and N and P content of remaining litter, KCl-extractable N and P from the humus and fauna content of litter and humus. This results in the following experimental setup:

8	climate treatments
<u>x3</u>	replicates
24	
<u>x2</u>	fauna treatments (+ and -)
48	
<u>x5</u>	sampling dates (0, 6, 12, 18, 24 months)
240	pots

This experiment was started in May 1994 (month 0).

## **3. Results**

### *Field Survey*

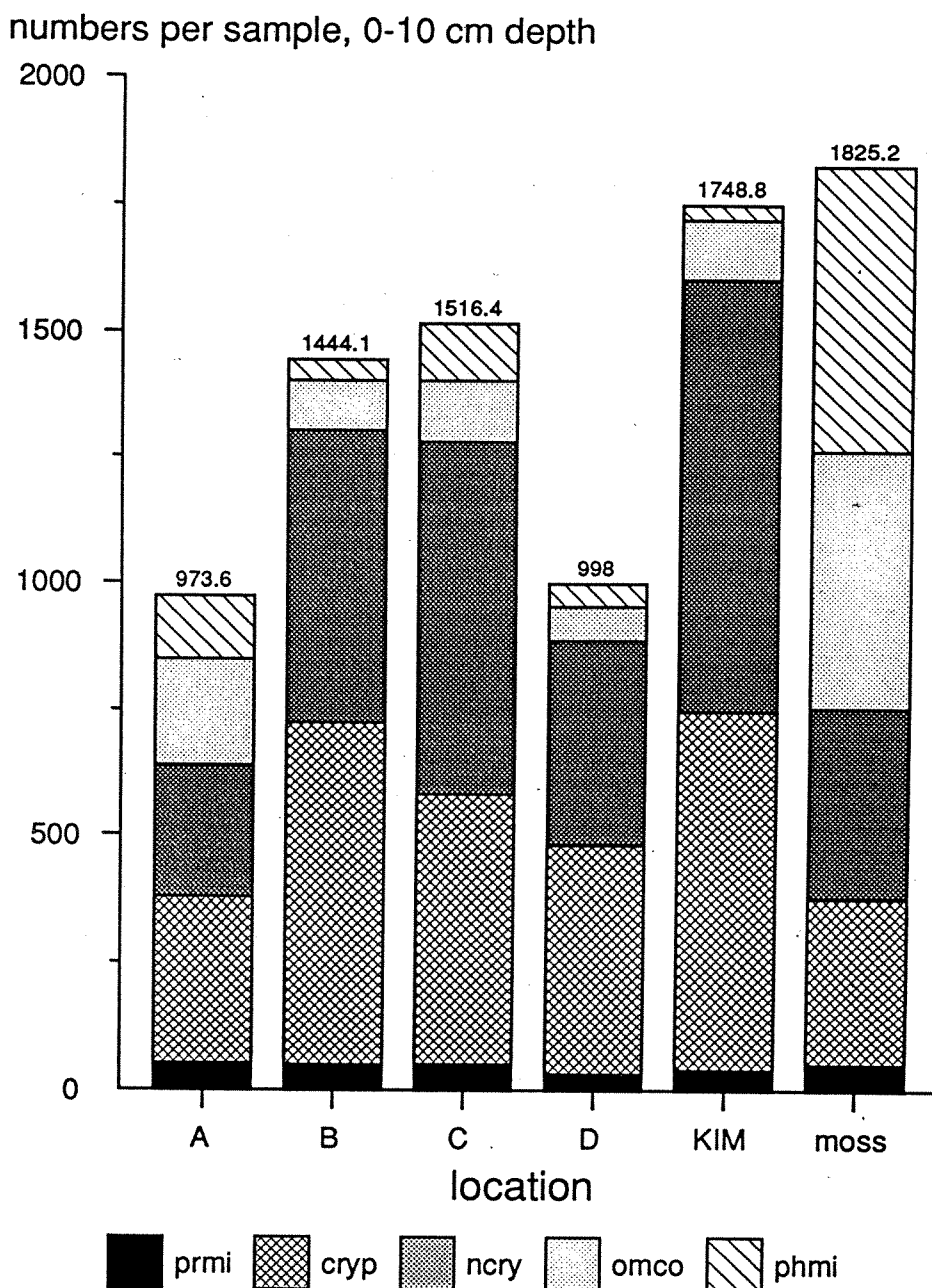
In 13 traps 21 macroarthropod individuals were captured, consisting of beetles (8), spiders (8) and ants (5) (Figure 9.2). On average 350 nematodes per gram dry soil were counted. Very few enchytraeids were found, probably because the extraction method used was not adequate for this faunal group.

Over 40% more microarthropods (primarily mites) were collected in a unit volume of soil in KIM than in the four similar catchments nearby. The mean of twelve replicates from the outside catchments (3 samples per catchment) was 1233 individuals versus a mean of 1749 for two replicate samples taken in KIM. The differences were not statistically significant due to the large variation and the small number of duplicates taken from KIM.

### *Litter Quality*

In April 1993 approximately 750 one-year-old *Betula pubescens* trees were potted and grown in greenhouses, one with ambient CO<sub>2</sub> and two with raised CO<sub>2</sub> level (700 ppm). Temperature was the same in all three greenhouses (maximum of 25°C). Half of the plants received water with the same composition as in the KIM catchment (clean precipitation) and the other half

received water with the same composition as EGIL (ambient acid precipitation). Senescent leaves were collected during summer and autumn and samples collected on July 18, October 4 and November 10 and were analyzed for C and N content (element analyzer) and lignin content (Nov. 10 samples only).



**Figure 9.2** Numbers of microarthropods collected during field sampling, Risdalsheia, September 28, 1993. Functional groups are predatory mites (prmi), cryptostigmatic mites (cryp), non-cryptostigmatic mites (ncry): omnivorous collembola (omco), and phytophagous mites (phmi). Catchments A-D are outside KIM (N = 3), "moss" is samples from the moss growing directly on bedrock (N = 2). N = 2 for KIM samples.

Enhanced CO<sub>2</sub> significantly decreased the N content and increased the C/N ratio ( $F_{\text{prob}} < 0.05$ ) of the leaves collected October 4 and November 10, but did not affect the C content (Table 9.3). There was no effect of CO<sub>2</sub> on leaves collected July 18 and no significant precipitation

effect on either the chemical composition of the leaves or on the total yield (dry weight). The increased CO<sub>2</sub> level significantly increased the total yield of the leaves ( $F_{\text{prob}} < 0.05$ ) (Table 9.4). No interaction between CO<sub>2</sub> level and precipitation composition was found.

**Table 9.3** Average leaf C, N and lignin content. N = 4 at CO<sub>2</sub> = 700 ppm; N = 2 at CO<sub>2</sub> = 350 ppm. Dates refer to leaf sampling dates.

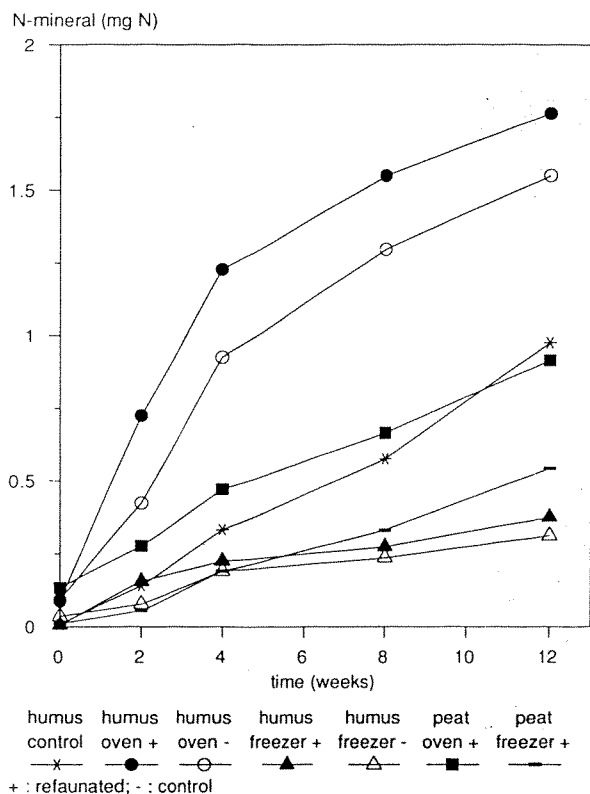
Water Quality	CO <sub>2</sub> (ppm)	%C	%N	C/N	%lignin	lignin/N
<i>July 18, 1993</i>						
clean	700	43.08	1.27	33.9		
clean	350	41.90	0.92	45.8		
ambient	700	42.63	1.03	41.3		
ambient	350	41.50	1.10	37.9		
<i>October 4, 1993</i>						
clean	700	40.08	0.48	83.1		
clean	350	39.85	0.71	56.5		
ambient	700	39.79	0.45	88.4		
ambient	350	39.25	0.59	66.5		
<i>November 10, 1993</i>						
clean	700	37.55	0.45	85.1	15.49	34.4
clean	350	38.05	0.56	68.7	16.72	29.9
ambient	700	37.40	0.41	90.8	15.86	38.7
ambient	350	37.60	0.46	81.8	16.17	35.2

**Table 9.4** Average total yield per year per plant (g dry weight). N = 7 at CO<sub>2</sub> = 700 ppm; N = 5 at CO<sub>2</sub> = 350 ppm.

Water Quality	CO <sub>2</sub> (ppm)	Yield	
		Mean	St. Dev.
clean	700	13.3	0.8
clean	350	12.4	0.6
ambient	700	13.3	1.2
ambient	350	12.3	0.6

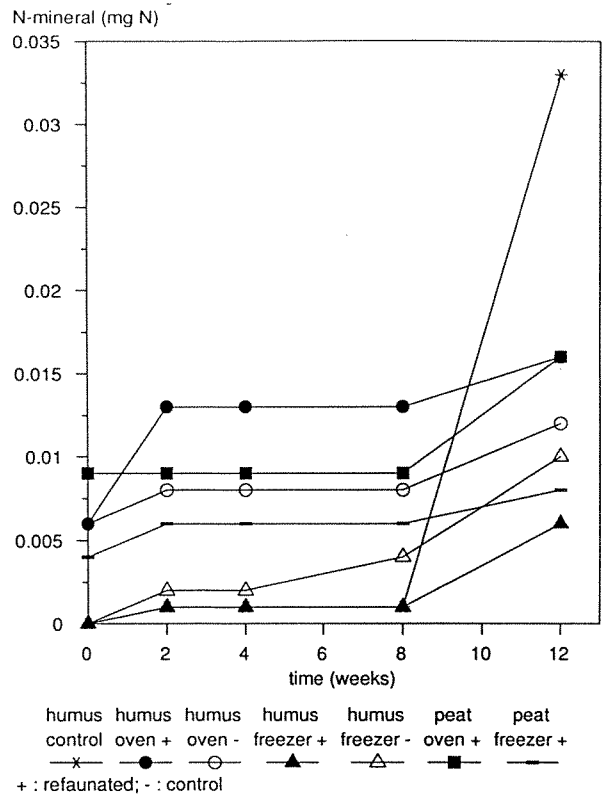
## Soil Fauna Mesocosms - Pilot Study

A pilot experiment was set up in October 1993 to decide on the method for defaunation of the soil, the method to refaunate the soil and the practice of leaching of humus and litter. As a substitute for the mesocosms we used 400-ml plastic pots filled with a 1-cm layer of washed coarse sand and 5 cm of either humus from the field site or garden peat (to investigate whether an alternative organic substrate could be used) overlain by 2 g freshly dried birch leaves which were packed in a 6 cm diameter sieve. The pots were defaunated in two different ways: by freezing (4x24 hr, -30°C (Huhta and Setälä 1990)), and by drying (4x24 hr, 45°C (Scholle et al. 1993)). Half were then refaunated with approximately equal numbers of microarthropods and incubated in darkness at a constant temperature of 20°C. They were leached with 40 ml demineralized water after 0, 2, 4, 8 and 12 weeks and the leachate was analysed for  $\text{NH}_4^+\text{-N}$  and  $\text{NO}_3^-\text{-N}$  (colorimetrically after 1:1 dilution with 2M KCl) (Figures 9.3 and 9.4). Pots were destructively sampled at weeks 0, 4 and 12, when microarthropods were extracted from both the humus/peat and the leaves and dry weight loss of the leaves was assessed (Figure 9.5). At week 12 both litter and humus/peat were also extracted with 1M KCl to measure the remaining mineral N content.

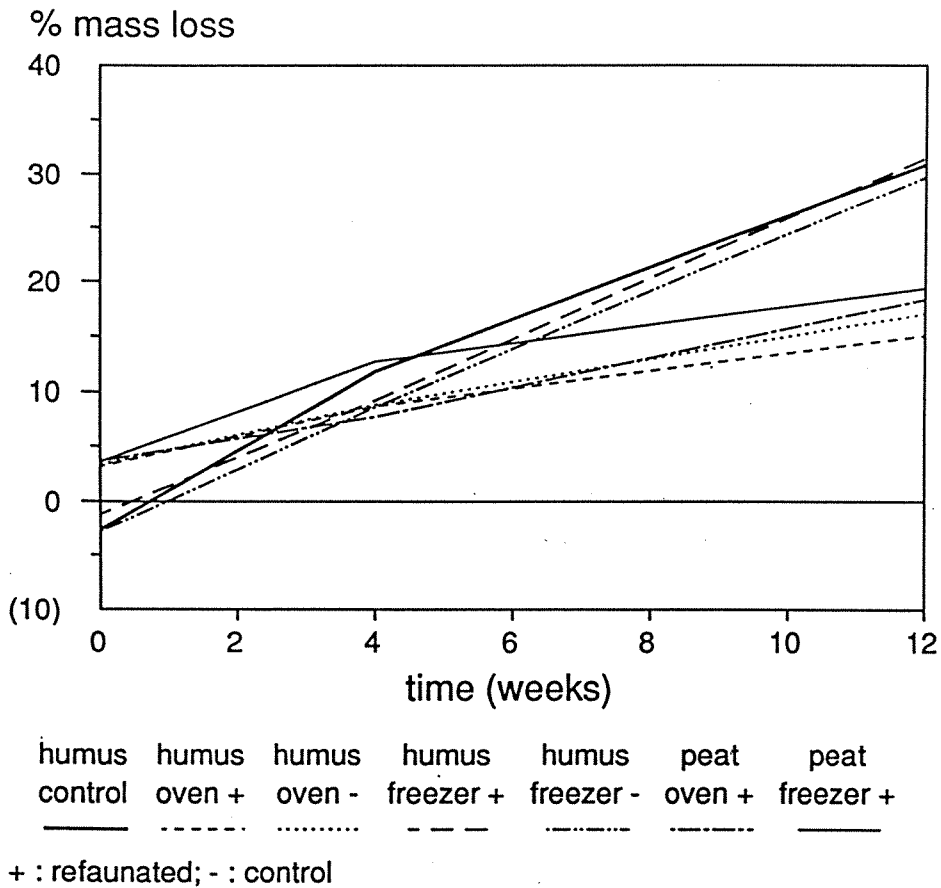


**Figure 9.3** Mesocosm pilot experiment: cumulative leaching results of soil. Average  $\text{NO}_3\text{-N}$  and  $\text{NH}_4\text{-N}$  in mg per pot.  $N = 3$ .

The freezing method was more successful than the oven-drying method for defaunation, but still not completely effective (Figure 9.6). We expect to accomplish complete defaunation if a temperature of -40°C can be reached, as recommended by Huhta and Setälä (1990). Incomplete defaunation, e.g., when predators are killed but not all the prey, may result in the observed population explosion of fast-reproducing species (Figure 9.6). A similar problem

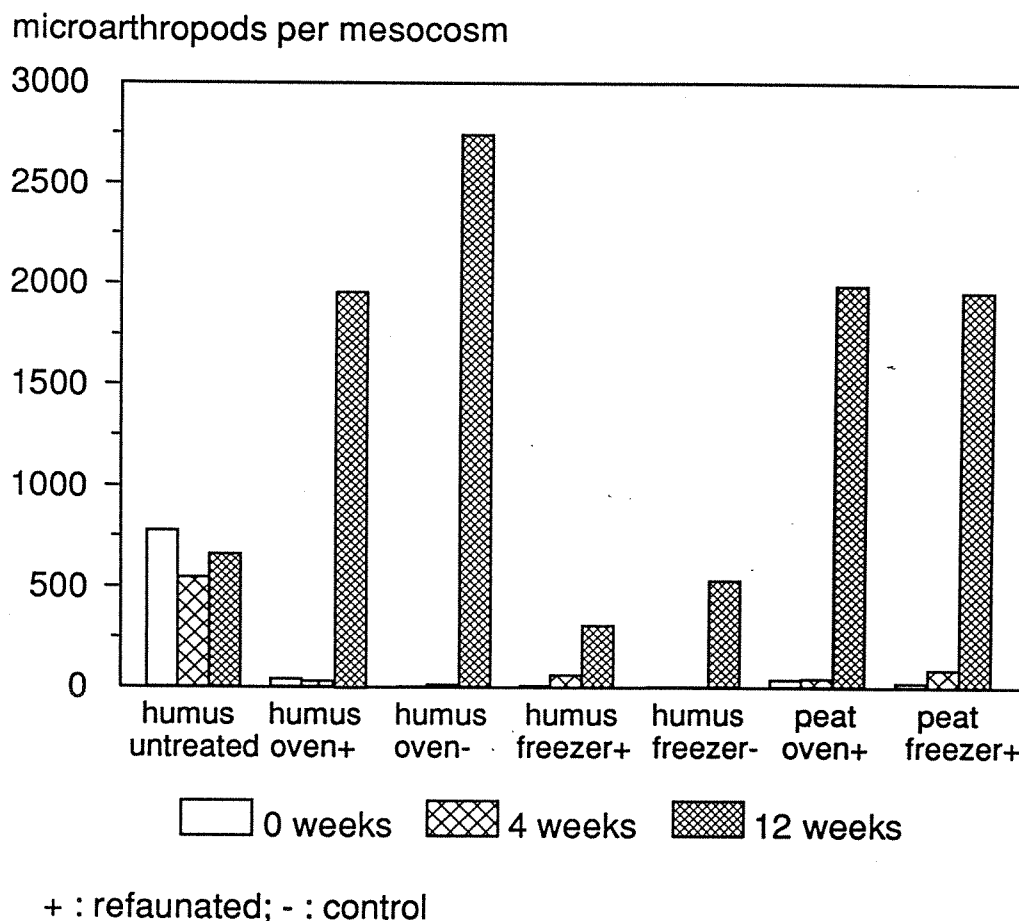


**Figure 9.4** Mesocosm pilot experiment: cumulative leaching results of litter. Average  $\text{NO}_3\text{-N}$  and  $\text{NH}_4\text{-N}$  in mg per pot.  $N = 3$ .



**Figure 9.5** Mesocosm pilot experiment: litter mass loss (loss of dry weight in %).

occurs if there is significant mortality of predators during the refaunation. The excessive numbers of microbivorous microarthropods in the 12th-week sampling of the refaunated pots suggests such an incomplete refaunation, i.e. the lack of live predatory mites.



**Figure 9.6** Mesocosm pilot experiment: average total number of microarthropods per pot (soil + litter). N = 3.

Beyond being more effective at defaunation, freezing also appears superior to heating with respect to minimizing soil chemical changes. In particular, the amount of N leached from the humus/peat after 12 weeks did not differ significantly between the freezer treatment and the control, but was significantly higher in the oven-treated material.

To reduce the amount of humus to be transported from Norway to the Netherlands and to minimize removal of material from the CLIMEX sites, we experimented with humus substitutes for use in the mesocosm and the plant uptake experiment. The results of the 12th week microarthropod extraction of the mesocosm pilot experiment indicate that the peat we used as an alternative substrate did not limit the development of microarthropods. The substrate best matching both the chemical and the physical characteristics of the original Norwegian raw humus is a mixture of bolster peat and cut pruning litter (2:3 weight ratio). Subsequent experiments will use this material.

#### 4. Time Scale

(d.s.: destructive sampling; l.s.: lysimeter sampling)

Year	Month	Litterbags	Mesocosm	Plant uptake
1994	April	placement/d.s.		
	May			start/d.s.
	June		start/l.s./d.s.	
	September		l.s.	
	October	d.s.		
	November			d.s.
	December		l.s./d.s.	
1995	March		l.s.	
	April	d.s.		
	May			d.s.
	June		l.s./d.s.	
	September		l.s.	
	October	d.s.		
	November			d.s.
December		l.s./d.s.		
1996	March		l.s.	
	April	d.s.		
	May			d.s.
	June		l.s./d.s.	

#### 5. References

- Anderson, J.M. 1973. The breakdown and decomposition of sweet chestnut (*Castanea sativa* Mill.) and beech (*Fagus sylvatica* L.) leaf litter in two deciduous woodlands. I. Breakdown, leaching and decomposition. *Oecologia* 12: 251-274.
- Coleman, D.C., Reid, C.P.P. and Cole, C.V. 1983. Biological strategies of nutrient cycling in soil systems. *Adv. Ecol. Res.* 13: 1-54.
- Coûteaux, M.-M., Mousseau, M., Célérier, M.L. and Bottner, P. 1991. Increased atmospheric CO<sub>2</sub> and litter quality: decomposition of sweet chestnut leaf litter with animal food webs of different complexities. *Oikos* 61: 54-64
- Eamus, D. and Jarvis, P.G. 1989. The direct effects of increase in atmospheric CO<sub>2</sub> concentration on natural and commercial temperate trees and forests. *Adv. Ecol. Res.* 19: 1-55.
- Huhta, V. and Setälä, H. 1990. Laboratory design to simulate complexity of forest floor for studying the role of fauna in the soil processes. *Biol. Fertil. Soils* 10: 155-162.



- Jonasson, S., Bryant, J.P., Chapin, F.S. and Andersson, M. 1986. Plant phenols and nutrients in relation to variations in climate and rodent grazing. *Am. Nat.* 128: 394-408.
- Laine, K.M. and Hettonen, H. 1987. Phenolics/nitrogen ratios in blueberry (*V. myrtillus*) in relation to temperature and microtine density in Finnish Lapland. *Oikos* 50: 389-395.
- Lemon, E.R. 1983. *CO<sub>2</sub> and plants: The response of plants to rising levels of atmospheric carbon dioxide.* Westview Press. Boulder CO.
- Luxmore, R.J. 1981. *CO<sub>2</sub> and phytomass.* *BioScience* 31: 626.
- Radoglov, K.M. and Jarvis, P.G. 1990. Effects of *CO<sub>2</sub>* enrichment on four poplar clones. I. Growth and leaf anatomy. *J. Exper. Bot.*(in press).
- Santos, P.F. and Whitford, W.G. 1981. The effects of microarthropods on litter decomposition in a Chihuahuan desert ecosystem. *Ecology*, 62: 654-663
- Scholle, G., Joergensen, R.G., Schaefer, M. and Wolters, V. 1993. Hexosamines in the organic layer of two beech forest soils: Effects of mesofauna exclusion. *Biol. Fertil. Soils* 15: 301-307.
- Setälä, H. and Huhta, V. 1991. Soil fauna increase *Betula pendula* growth: Laboratory experiments with coniferous forest floor. *Ecology* 72: 665-671.
- Setälä, H., Martikainen, E., Tyynismaa, M. and Huhta, V. 1990. Effects of soil fauna on leaching of nitrogen and phosphorous from experimental systems simulating coniferous forest floor. *Biol. Fertil. Soil* 10: 170-177
- Setälä, H., Tyynismaa, M., Martikainen, E. and Huhta, V. 1991. Mineralisation of C, N and P in relation to decomposer community structure in coniferous forest soil. *Pedobiologia* 35: 285-296.
- Thomas, J.F. and Harvey, C.N. 1983. Leaf anatomy of four species grown under continuous long-term *CO<sub>2</sub>* enrichment. *Bot. Gaz.* 144: 303-309.
- Verhoef, H.A. and Brussaard, L. 1990. Decomposition and nitrogen mineralisation in natural and agro-ecosystems; the contribution of soil animals. *Biogeochemistry* 11: 175-211.

# Chapter 10

## *Integration: Pre-Treatment Status of CLIMEX Catchments*

---

N. Dise and A. Jenkins

Institute of Hydrology  
Wallingford  
Oxon OX108BB  
United Kingdom

### 1. Introduction

The CLIMEX project makes use of three catchments which have been manipulated and extensively investigated for ten years as part of the RAIN project. This is both an advantage and a disadvantage. The great advantage of this setup is the excellent database, particularly of surface water chemistry and soil chemistry, which has been continually accumulated since 1984. This long monitoring history permits separation between natural year-to-year variation and the effect of a treatment, and establishes a baseline for water and soil chemistry of KIM, EGIL and ROLF against which the effects of the CLIMEX manipulations will be clear. It has also shown that, for soil chemistry and input-output budgets, the effect of the roof is minimal (Chapters 4 and 5).

The disadvantage of the RAIN catchments is that the effect of the CLIMEX treatment is superimposed on a deposition treatment (clean rainfall since 1984). In this report, therefore, in addition to detailing the investigations currently being carried out in the CLIMEX project, we compare measurements made among the different catchments during the pre-treatment year. Plausible effects of the roof or the rainfall treatment on the biota should show up as differences among the catchments that can be used as a baseline for the CO<sub>2</sub> and temperature treatments.

A central theme of CLIMEX is interactions. High CO<sub>2</sub>, for example, should decrease the water loss of the plant (stomata do not need to be open as much to take in sufficient CO<sub>2</sub> for photosynthesis), thus increasing soil moisture. Higher temperatures, however, should have the opposite effect -- increasing plant water loss through increased evapotranspiration. Enhanced CO<sub>2</sub> in a nitrogen-limited environment can lead to an increase in root growth to enable greater N uptake. How N availability is affected by climate change depends on the opposing effects on decomposition of an increase in temperature and a lower litter quality, together with the soil moisture effect (Figure 1). Thus, the *integrative* effect of CO<sub>2</sub> and temperature on the ecosystem can be explored only with an experiment like CLIMEX. *Separate* effects, however, need to be examined at the same time. Therefore, as a preliminary to the CLIMEX study, several investigators conducted greenhouse experiments with single treatments applied to individual plants in pots. These studies will be linked with results from CLIMEX, which will incorporate the ecosystem response to the treatments.

Results from single treatments can help separate the mix of forcing effects acting on the biota in the CLIMEX catchments.

This chapter provides the major results from the pre-treatment year collated from the previous nine chapters. By reporting results from different investigations together, we aim to provide a coherent picture of the pre-treatment status of the catchments and the CLIMEX experiments.

## **2. What is the existing variability in the physical/chemical environment of the CLIMEX catchments?**

### *Variability Due to Site Differences*

#### *Size*

The order of size among the catchments varies fourfold as follows: KIM (860 m<sup>2</sup>) > METTE > EGIL > CECILIE > ROLF (220 m<sup>2</sup>). Among other things, size affects the number of species found (through simple probability) and the number of individuals of any one species. For example, whereas there are 39 pine and 35 birch in KIM, there are only 6 pine and 3 birch in ROLF. With smaller sample sizes, differences among sites must be much greater to be statistically significant.

#### *Soil depth*

Soil depth influences the water storage capacity of the soils, and thus their frequency of drying. Soils are shallowest in EGIL, with no soils deeper than 30 cm. Some deeper soils are present in ROLF (30-45 cm), but are restricted by the small catchment size. Deeper soils (45+ cm) are present in KIM, METTE and CECILIE. Soils are shallower in both control sections of KIM and EGIL.

### *Variability Due to the Roof*

#### *Solar radiation*

The roofs in KIM and EGIL cause a reduction of approximately 50% of incoming photosynthetically active radiation (Chapter 2). This does not, however, seem to greatly affect air or soil temperature.

#### *Air*

Wind is reduced under the roof and is probably even more reduced with the construction of the KIM walls to the ground surface. Fans in KIM help compensate somewhat for reduced air movement. Humidity was not different in the background year between roofed and non-roofed catchments, but has been increased in KIM since the walls have been constructed.

#### *Deposition*

Decreased fog deposition under the roof means that dry deposition has been reduced to KIM and EGIL. This has reduced inputs of both nutrients and acidity to the catchments.

## *Variability due to the Precipitation Treatment*

### *Size, intensity, frequency of rain*

Sprinkling intensity and raindrop size are constant under the roof whereas there is great variation outside. Additional water is added under the roofs during early spring (snowmelt in open catchments) and occasionally during droughts in summer to avoid permanent damage to the vegetation.

### *Precipitation chemistry*

The input of major cations and anions, especially  $H^+$ ,  $NO_3^-$ ,  $NH_4^+$  and  $SO_4^{2-}$ , have been reduced in KIM since 1984. The deposition of base cations has been reduced to less than 1/2 of ambient precipitation, while inputs of strong acid anions have been reduced to nearly 1/3 of ambient. This is reflected in comparable reductions in base cations and strong acid anions in runoff and a large increase in acid neutralizing capacity, but only a small increase in pH (Chapter 4). The decrease in strong acid anions has been compensated by organic anions. This is also seen in the soil solution (Chapter 5). There are as yet no clear effects of the treatment on soil chemistry (e.g., exchangeable cations, adsorbed sulphate).

## **3. How Does this Physical and Chemical Variability Influence the Biology?**

A. In measurements made in August 1993, leaf temperatures of trees and shrubs growing under the roof in KIM were higher than those growing in the open in METTE (Chapter 8). Stomatal conductance of *Betula*, *Pinus*, and *Vaccinium myrtillus* is reduced in KIM, and rates of photosynthesis were out of phase for *Betula* and *Pinus* and reduced for *Pinus* and *Vaccinium*. There is a marked reduction in photosynthetic rates per internal leaf  $CO_2$  concentration ( $A/C_i$  rates) (broadly speaking, a photosynthetic "efficiency") for *Vaccinium* in KIM. This is possibly due to the fact that *Vaccinium* is growing on thinner soils in KIM which dry out more quickly. Carboxylation rates (the activity of the rubisco enzyme) for all three species were higher in KIM than outside the roof. This may indicate some evidence of acclimatization to the lower light levels depression under the roof, especially with *Vaccinium myrtillus*.

B. Decomposition rates of *Pinus sylvestris* appear to be faster under the roofed catchments KIM and EGIL than in the open catchment ROLF (Chapter 5). A pilot study showed a one-year mass loss of 30% for pine grown in KIM, 25% for EGIL and 22% for ROLF. This may be due to annual warmer soil temperature under the roofs. Nitrogen mineralization of *Calluna* appears to be higher in the treatment section of EGIL than the control section of EGIL. This is likely to be due to a combination of differences in soil depth, soil temperature and soil moisture.

C. *Vaccinium* stems are significantly thicker in KIM than METTE (EGIL not measured since very little *Vaccinium*), and shoot segments are longer with more leaves (Chapter 6). This may be due to warmer soils or precipitation differences, although there are no difference in stem diameter among the catchments for *Calluna*. There are significantly more short shoots and flowers of *Calluna* plants in METTE as compared to the roofed catchments, possibly from reduced solar radiation. *Calluna* stems are thinner and shorter in the KIM control than

in the KIM experimental plot. *Calluna* can possibly tolerate drier soils than *Vaccinium*, but needs more light.

D. Tree growth is strongly enhanced under the clean-rain catchment KIM, especially near the roof (Chapter 7). Growth is also enhanced in the acid rain catchment EGIL, but only among trees touching the roof. This may be partly due to higher temperatures near the roof and less wind stress, warmer soil temperatures, sprinkling during drought and the clean rain treatment. Antecedent conditions may also play a role: trees were taller in KIM and were closer to the roof at the start in of the experiment.

E. For pine needles and birch leaves, concentrations and amounts of Mg, K and (needles only) Ca are significantly higher under KIM (clean) than EGIL (acid rain) (Chapter 7). Concentrations are intermediate in the open catchments METTE and CECILIE. This may in part be a deposition effect. Nitrogen concentration of needles was higher in the acid rain catchments than in the clean rain catchment, suggesting either enhanced uptake due to a higher supply of nitrogen in deposition, or possibly stress from the acid rain treatment.

F. Over 40% more microarthropods (primarily mites) were collected in a unit volume of soil in KIM than in four similar catchments nearby (Chapter 9). The mean of twelve replicates from the outside catchments (3 samples per catchment) was 1233 individuals versus a mean of 1749 for two replicate samples taken in KIM.

#### **4. What have the CLIMEX greenhouse experiments indicated as the likely effects of increasing temperature, increasing CO<sub>2</sub> and changing nitrogen deposition, as well as the likely interactions?**

A. Increasing CO<sub>2</sub> and temperature stimulate both the photosynthetic rate (A) and the photosynthetic efficiency (A/C<sub>i</sub>, or photosynthetic rate per unit of internal C) of *Vaccinium vitis-idea* (Figure 9.10, Table 9.2). Both parts of photosynthesis are enhanced: the rate of carboxylation and the rate of electron transport. There is also a strong adaptation effect: plants grown under elevated temperature have much higher A/c<sub>i</sub> rates than controls, and those grown under both elevated CO<sub>2</sub> and elevated temperatures have still higher A/c<sub>i</sub> rates (Figure 9.11).

B. Increasing CO<sub>2</sub> increases both water use efficiency and biomass of the grass species *Molinia caerulea* and *Arrhenatherum elatius* (Chapter 6). The large increase in water use efficiency (ca 50%, regardless of N) means that plants would be able to withstand drought better. The growth effect of CO<sub>2</sub> needs to be "released" by N, therefore, there is a significant synergistic effect of CO<sub>2</sub> and N on biomass. Surprisingly, slow-growing species such as those found in the CLIMEX sites appear to respond as much or more to the treatments than fast-growing species in their experiment, perhaps because N is still limiting for the fast-growers.

C. Increasing CO<sub>2</sub> slightly increases the total yield of leaves for birch seedlings and increases the C/N ratio of birch leaves, but the effect is a significantly decreased N content, rather than any effect of C (Chapters 5 and 9). "Clean" precipitation appears to have no significant effect on either birch leaf chemical composition or total yield.

**5. What may be considered the net ecosystem differences between KIM catchment and the controls at the start of CLIMEX?**

A. *Lower light*: higher rubisco enzyme levels, possibly lower numbers of shoots and flowers for *Calluna*.

B. *Thinner soils*: lower photosynthetic efficiencies (A/c<sub>i</sub>) for *Vaccinium*.

C. *Warmer air* directly under the roof, *warmer soils*: Higher decomposition (partial effect, also may be due in part to clean rain treatment), thicker *Vaccinium* stems, enhanced tree growth (partial effect), higher fauna numbers (partial effect).

D. *Clean rain*: higher decomposition (partial effect), higher tree growth (partial effect), higher needle cation concentrations, lower needle N, higher soil fauna numbers (partial effect).

The observed differences between KIM and other catchments are not necessarily due to the treatments. Of greatest importance is the fact that the existing variability has been investigated and is now documented. Additionally, the greenhouse studies have suggested the effects likely to occur when temperature and CO<sub>2</sub> are raised in CLIMEX. These large-scale manipulations of CLIMEX will undoubtedly cause responses in vegetation, soils and waters both expected and unexpected. The challenge of CLIMEX is to document these responses relative to the pre-treatment database described here.



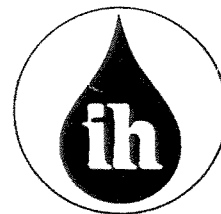
## CLIMATE CHANGE RESEARCH REPORTS

- 1/1995 Jenkins, A. (ed). 1995. CLIMEX Climate Change Experiment: Progress Report December 1992 - June 1993. 12 pp.
- 2/1995 Jenkins, A. (ed). 1995. CLIMEX Climate Change Experiment: Progress Report July 1993 - December 1993. 31 pp.
- 3/1995 Dise, N. B., and Jenkins, A. (eds). 1995. The CLIMEX project: Whole catchment Manipulation of CO<sub>2</sub> and Temperature. 130 pp.
- 4/1995 Jenkins, A. (ed). 1995. CLIMEX Climate Change Experiment: Final Report on Phase I the first year of treatment May 1994 - December 1994. 47 pp.
- 5/1995 Wright, R.F., Indrøy, A-S., Høgberget, R., Lükewille, A., Sørvåg, T., and Willbergh, M. 1995. CLIMEX Project. Climate data for first year of treatment April 1994 - March 1995. 21 pp.



**Norwegian Institute for Water Research**  
P.O.Box 173, Kjelsås  
N-0411 Oslo, Norway

Phone: + 47 22 18 51 00  
Fax: + 47 22 18 52 00



**Institute of Hydrology**  
Wallingford  
OXON OX10 8BB, UK

Phone: + 44 14 91 83 88 00  
Fax: + 44 14 91 69 24 30

ISBN: 82-577-2921-3