

REPORT SNO 3521-96

**E**stablishment of  
Scientific Contacts within  
Environmental Protection  
between NIVA and  
POLTEGOR, Poland

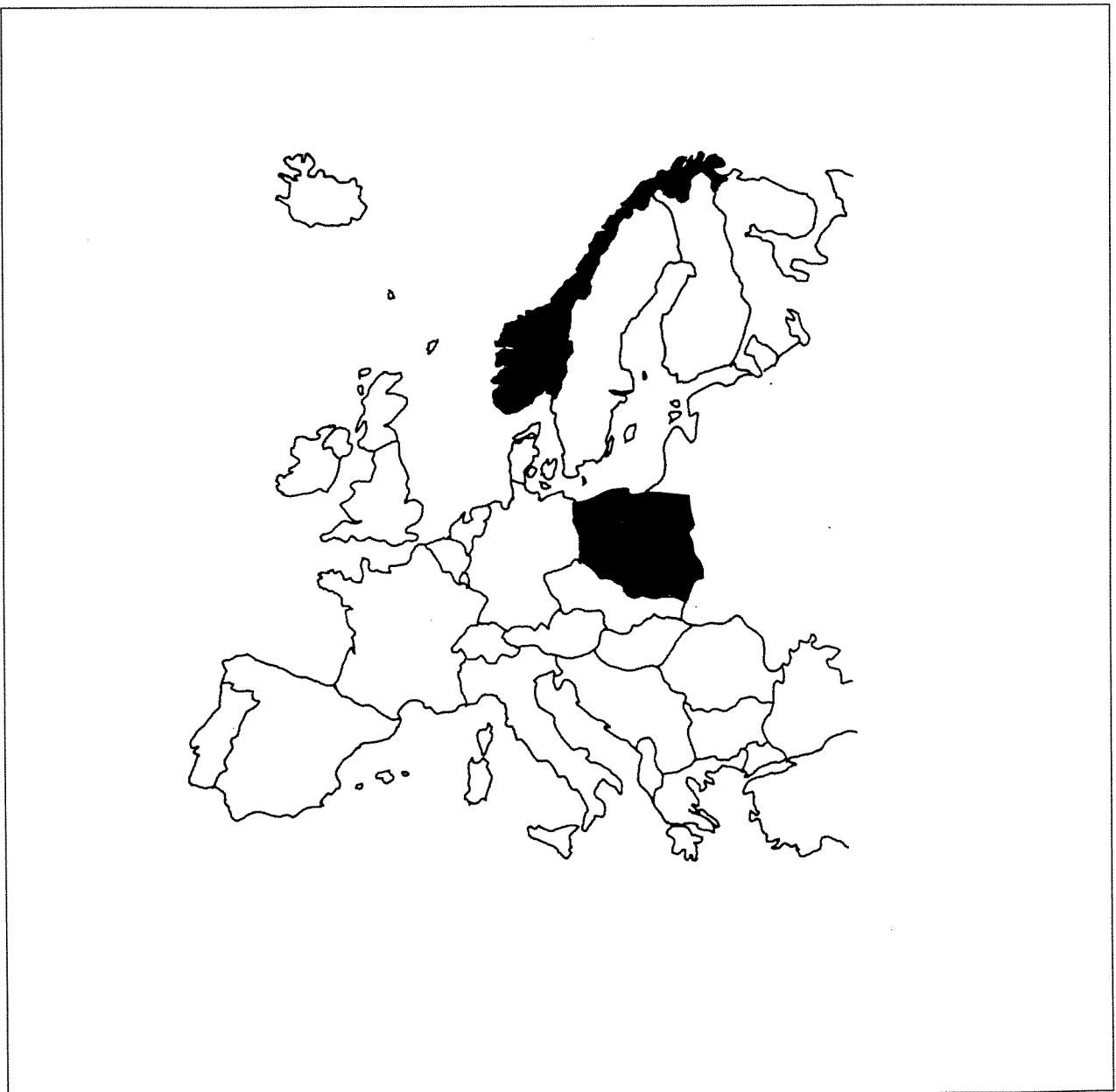

**Main Office**

P.O. Box 173, Kjelsås  
N-0411 Oslo  
Norway  
Phone (47) 22 18 51 00  
Telefax (47) 22 18 52 00

**Regional Office, Sørlandet**

Televeien 1  
N-4890 Grimstad  
Norway  
Phone (47) 37 04 30 33  
Telefax (47) 37 04 45 13

**Regional Office, Østlandet**

Rute 866  
N-2312 Ottestad  
Norway  
Phone (47) 62 57 64 00  
Telefax (47) 62 57 66 53

**Regional Office, Vestlandet**

Thormøhlensgt 55  
N-5008 Bergen  
Norway  
Phone (47) 55 32 56 40  
Telefax (47) 55 32 88 33

**Akvaplan-NIVA A/S**

Søndre Tollbugate 3  
N-9000 Tromsø  
Norway  
Phone (47) 77 68 52 80  
Telefax (47) 77 68 05 09

Title Establishment of Scientific Contacts within Environmental Protection between NIVA and POLTEGOR, Poland.	Serial No. 3521-96	Date 1996.08.08
	Report No. Sub-No. O - 95156	Pages Price 7+Appenices
Author(s) Grazyna Englund	Topic group International activities	Distribution
	Geographical area Poland/ Norway	Printed NIVA

Client(s) Norwegian Pollution Control Authority (SFT), Norwegian Ministry of Environment (MD) and Norwegian Foreign Ministry (UD)	Client ref. 95/1633-3 UD nr. 7960 - 8023
--	--

<p>Abstract</p> <p>After initiative from researchers from the Polish Mining Institute (POLTEGOR) from Wroclaw, the three researchers visited NIVA, SFT, Elkem Mangan PEA in Porsgrunn and Denofa and Lilleborg Factory A/S in Fredrikstad.</p> <p>This visit was aiming in learning about the Norwegian approach to environmental protection connected to mining activities, as well as utilisation of the waste from the edible oil production. By the exchange of the experiences new contacts were established, which will, hopefully, lead to future co-operation.</p>
--

<p>4 keywords, Norwegian</p> <ol style="list-style-type: none"> <li>1. Bilateralt samarbeid</li> <li>2. Etablering av forskningskontakter</li> <li>3. Miljøløsninger</li> </ol>	<p>4 keywords, English</p> <ol style="list-style-type: none"> <li>1. Bilateral co-operation</li> <li>2. Establishment of scientific contacts</li> <li>3. Environmental solutions</li> </ol>
---	---

  
Grazyna Englund  
Project manager

ISBN 82-577-3065-3

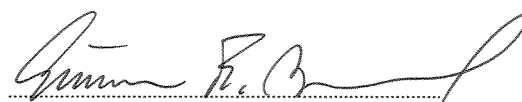
  
Gunnar Fr. Aasgaard  
Head of research department

## Preface

*Initiative for this contact was taken by the Polish Mining Institute (Poltegor) from Wroclaw, Poland. Three researchers from this Institute intended to use their grant on a visit to Norway in order to learn more about the Norwegian approach to the environmental protection connected to mining activities, as well as utilisation of the waste from the edible oil production. The Norwegian Institute for Water Research (NIVA) was requested by the Norwegian Ministry of Environment to organise the visitors professional activities in Norway.*

*The following team from Poltegor was visiting us:*

*Professor Kazimierz Ukleja*

*Ph.D. Jan Rogut*

*M.Sc. Adam Grzelak*

*From NIVA:*

*Grazyna Englund, Research Scientist, responsible for the organisation of the visit.*

*Eigil Rune Iversen, Research Scientist, responsible for the visit of the nickel mine.*

*Rolf Tore Arnessen, Senior Research Scientist, helpful in establishing the professional contacts with the SFT, Division of Industry.*

*Gunnar Fr. Aasgaard, Head of Research Department, Environmental Technology, quality assurance.*

*NIVA would like to thank the Elkem Mangan PEA and A/S Denofa og Lilleborg Fabrikker for their hospitality and fruitful discussions.*

*Oslo, 05.08.96*

*Grazyna Englund*

# Contents

Preface.....	2
Summary .....	4
1. Introduction.....	5
1.1 Mining Institute, POLTEGOR, Wroclaw, Poland .....	5
1.2 Norwegian Institute for Water Research, NIVA, Oslo.....	5
2. Program of the Visit .....	6
3. Evaluation and Conclusions.....	7
4. Acknowledgements .....	7
5. Appendices.....	8
Appendix 1: Start of the project.....	8
Appendix 2: NIVA Projects in Central and Eastern Europe 1990 - 1996 .....	9
Appendix 3: Information about Poltegor .....	10
Appendix 4: Information about NIVA .....	11
Appendix 5: Presentations at NIVA Seminar .....	12
Appendix 6: Information about SFT .....	13
Appendix 7: Information about Elkem Mangan PEA .....	14
Appendix 8: Information about Ertelien Nickel Mine .....	15
Appendix 9: Information about Denofa og Lilleborg Fabrikker A/S .....	16
Appendix 10: Memorandum .....	17

## Summary

As a result of the request from the Mining Institute (Poltegor), Wroclaw, Poland, directed to the Norwegian Ministry of Environment, NIVA was responsible for the organisation of a visit of the representatives of Poltegor in Norway, to provide the necessary scientific contacts with the fellow Research Scientists at NIVA and other Institutes (Appendix 1).

Three researchers from this Institute intended to use their grant on a visit to Norway in order to learn more about the Norwegian approach to environmental protection connected to mining activities, as well as utilisation of the waste from the edible oil production.

The objectives of these contacts were to exchange the experiences as well as to establish scientific contacts which could lead to future co-operation.

Poltegor representatives have visited SFT's division for industry, Elkem Mangan PEA in Porsgrunn, Ertelien Nickel Mine, and the Edible Oil Production Factory Denofa and Lilleborg A/S in Fredrikstad.

Professional contacts were established at the mentioned institutions and companies.

# **1. Introduction**

## **1.1 Mining Institute, POLTEGOR, Wroclaw, Poland**

POLTEGOR - Institute is a research institute within Open Cast Mining since 1950. This institute, which was traditionally working on mining problems was divided in two in 1970; one working with mostly design and second - research and development. From then on POLTEGOR - Institute worked with research not only within mining and its influence on environment, but also on other environmental issues.

Institute now works in four directions:

1. Geological engineering
2. Hydrogeological engineering
3. Geotechnics and environmental protection
4. Automation.

Institute has its own laboratory and workshop.

POLTEGOR co-operates with many other institutions and companies in Poland and abroad.

Some more information about Poltegor are attached folder in Appendix 3.

## **1.2 Norwegian Institute for Water Research, NIVA, Oslo**

NIVA has been Norway's leading research centre of water related expertise since 1958. NIVA is a non-profit research foundation which carries out research, surveys and development work on contracts for public authorities and private clients in Norway and abroad. NIVA has a staff of 190, of whom 90 are research scientists. NIVA does research on environmental technology connected to treatment of water and wastewater, aiming to find practical solutions to environmental problems in water. NIVA takes actively part in the environment related projects in Eastern Europe, where a number of projects are related to Poland. For the titles of the projects, please refer to the attached NIVA-information sheet (Appendix 4).

## 2. Program of the Visit

Program for the visit of three researchers from POLTEGOR (The Mining Institute) in Wroclaw, Poland.

Date: 21th -25th of August 1995

Place: NIVA, SFT, Smelting-works, Mine-works, Edible oil/Margarine production

Responsible: Grazyna Englund

Visitors: 1. Prof. dr. hab. eng. Kazimierz Ukleja

2. dr.ing. Jan Rogut

3. M.Sc. Adam Grzelak

Day	Time	Activities
Day 1 21.08 Mond.	0915-0945	• Short presentation of the visitors (K. Ukleja/ J. Rogut/ A. Grzelak)
	0945-1000	• General information about the NIVA and NIVA`s activities (Finn Medbø)
	1000-1015	• General information about the Environmental Technology department (Bente M. Wathne)
	1015-1030	• Strategy and main activities within wastewater technology (Grazyna Englund)
	1030-1130	• Visiting the NIVA building (Grazyna Englund)
	1130-1300	• NIVA-SEMINAR (NIVA-employees) (Appendix 5) Presentation of the POLTEGOR Institute 1. Use of electro-kinetics for improvements of grouts and clean-up chemicals at hazardous waste sites (Prof. Kazimierz Ukleja) 2. Removal of heavy metals from aqueous waste streams in hollow fibre extractors (dr. Jan Rogut) 3. Possibilities of utilisation of brown coal in agriculture, ecology and breeding (M.Sc. Adam Grzelak)
	1300-1345	• Lunch and General, informal discussions
	1400-1500	• Visiting the Norwegian Pollution Control Authority (SFT) - department for industry, control division (Grete Braastaad and Karl Nordbraathen)
	1515-1615	• Meeting with the wastewater treatment group at NIVA
	1730	Dinner

Day 2 22.08. Tues.	0800-1800	<ul style="list-style-type: none"> <li>• Visiting a smelting-works and wastewater treatment plant at Porsgrunn Elektrometallurgiske Fabrikker (Elkem Mangan PEA) (Arne Kjellsen, Håkon Grevsatd, Morten Honstad)</li> </ul>
Day 3 23.08. Wed.	0830-1000 1000-1700	<ul style="list-style-type: none"> <li>• Presentation of measures for reduction of mine pollution in Norway (Eigil Rune Iversen)</li> <li>• Visiting the mining activities around Oslo (Ertelien Nickel Mine or Copper Works) (Eigil Rune Iversen)</li> </ul>
Day 4 24.08. Thurs.	0800-1500 1500-1700	<ul style="list-style-type: none"> <li>• Visiting an Edible Oil Production Factory - Denofa and Lilleborg A/S in Fredrikstad (Bjørn H. Jensen, Åge Frydenberg)</li> <li>• Evaluation and identification of project ideas and co-operation possibilities (Gunnar Fr. Aasgaard, Grazyna Englund)</li> </ul>
Day 5 25.08. Friday	0830-0930 0930-1030	<ul style="list-style-type: none"> <li>• Visiting Polish Embassy (Mr. Szustka)</li> <li>• Visiting the NIVA library</li> </ul>

Information about visited places are represented in Appendices 6-9.

### 3. Evaluation and Conclusions

The main objectives of the visit were to exchange professional experiences, to bring the Polish representatives in touch with the scientists of relevant interests in Norway, and to discuss possibilities for future co-operation. All these objectives were achieved and the participants were engaged in discussions on possible future collaboration.

Memorandum from the working-study visit of POLTEGOR Institute representatives at the Norwegian Institute for Water Research (NIVA) was signed by the both sides (Appendix 10). One project proposal is in preparation.

### 4. Acknowledgements

NIVA is thankful to SFT for the assistance provided, both financially and professionally. NIVA would like to express our appreciation to: Nina Hedlund Markussen, Grete Braastad, Karl Nordbraathen and their colleagues at SFT, Morten Honstad, Haakon Gravestad and Arne Kjellsen from Elkem Mangan PEM, and Bjørn H. Jensen and Åge W. Frydenberg from Denofa og Lilleborg A/S Fabrikker, for all help. Also NIVA colleagues who participated in discussions and exchange of experiences are thanked.



# 5. Appendices

## Appendix 1: Start of the project

MILJØVERNDEPARTEMENTET  
P.B. 8013, DEP 0030 Oslo.

O Ø MILJØVERNER.	
SAK NR:	DATO:
94/3754-1	7/9-94

KOPI  
Stavanger, den 3/9-9

Vedr. kontakt mellom polske miljøvernforskere og norske institusjoner.

2 polske miljøvernforskere som er ansatt i instituttet POLTEGOR i Wrocław, prøver på denne måten å komme i kontakt med det norske fagmiljøet, som driver med aktivt vern av jordoverflaten og grunnvannet mot forurensning med tungmetaller. Vedkommende personer er: prof. dr. ing. Kazimierz Ukleja og siv. ing. Adam Grzelak. De har i mange år arbeidet med vannforurensningsproblematikken, hovedsakelig på kommersiell basis, mot kommuner, gruver, smelteverk og oljeraffinerier. Undertegnede, som er venn med disse to, har også arbeidet i samme forskningsteam ved Poltegor instituttet i Wrocław i årene 1972-74, men siden okt. 1974 vært bosatt i Norge og fra 1986 er geofysiker i Statoil. Vedkommende personer er kjent med Norges ledende stilling i miljøspørsmål og har derfor ønsket å bruke sitt reisestipend til å besøke Norge og bli kjent med miljøvern, spesielt rundt smelteverk og oljeraffinerier. De vil også gjerne presentere sitt arbeid. Disse to har ingen faglig kontakt i Norge, derfor har de valgt denne formen for henvendelse. Kunne Departementet se noen mulighet for slik kontaktformidling med et norsk firma/institutt, ville det glede meget disse to. Forhåpentlig vil dette også være til nytte for begge parter.

Nedenfor følger kontakt adresse:

prof. Kazimierz Ukleja/ siv. ing. Adam Grzelak, Poltegor - Instytut,  
ul. PARKOWA 25, 51-616 WROCLAW, Polen.

tel. 095 48 71 48 42 81, fax nr: 095 48 71 48 43 20.

Med vennlig hilsen  
*Andrzej Baranowski*  
Andrzej Baranowski

Einevollveien 4, 4017 Stavanger

tel. hjem 51 58 18 66,

tel. arb. 51 80 65 53.



# DET KONGELIGE MILJØVERNDEPARTEMENT

KONTOR: MYNTGT.2 - TLF.22 34 90 90 - FAX.22 34 95 60 - TELEKS 21480 env n  
POSTADRESSE: POSTBOKS 8013 DEP., 0030 OSLO

Ø saksbeh  
GEN  
↓  
Kopi Gaa  
Ann.

Norsk Institutt for Vannforskning  
Postboks 173 Kjelsås  
0411 Oslo

NORSK INSTITUTE FOR VANNFORSKNING	
Innr.:	3576194
Sak nr.:	421-0
Mottatt:	4.10

Deres ref.

Vår ref. (bes oppgitt ved svar)  
94/3754  
Ark.

Dato - 3 OKT. 1994

## Ønske om kontakt med norske fagmiljøer fra polske forskere

Vedlagt følger en forespørsel om norske forskningskontakter fra to polske forskere som ønsker å bruke sitt reisestipend til å besøke Norge og bli kjent med miljøvern særlig i tilknytning til smelteverk og oljeraffinerier. NIVA bes med dette vurdere sin interesse av å følge opp forespørselen, eventuelt videreformidle forespørselen til andre relevante forskningsmiljøer.

Med hilsen

Jon Rørvik e.f.  
ekspedisjonsjef

Bente Herstad

Vedlegg: Forespørsel fra Andre Baranovski av 3.9.94

Kopi: Norges forskningsråd, v. Området for miljø og utvikling  
Andre Baranovski, Einevollveien 4, 4017 Stavanger  
Avdelingene, her

Saksbehandler: Bente Herstad, tlf.: 22345750

NIVA  
Postboks 173 Kjelsås  
0411 Oslo

Statens  
forurensningstilsyn



Postadresse: Pb. 8100 Dep, 0032 Oslo  
Kontoradresse: Strømsveien 96  
Telefon: 22 57 34 00 Telefax: 22 67 67 08

NORSK INSTITUTT FOR VANNFORSKNING	
J.nr.:	1642/95
Sak nr.:	404
Mottatt:	8.6

GEN  
GAA  
NER  
ASS  
HAR  
AEN  
WE

Deres ref..

Vår ref. (Bes oppgitt ved svar)  
95/1633-3 NHM  
341.1

Dato

08 JUNI 1995

Statsbudsjettet 1995, Kap. 0118 Post 73

**TILSAGN OM MIDLER TIL Å ETABLERE FORSKNINGKONTAKT  
INNENFOR MILJØVERN MELLOM NIVA OG POLTEGOR, POLEN.  
UD nr. 7960 - 8023**

Svar på Deres søknad om støtte til prosjekt i regi av miljøsamarbeidet med Øst-Europa: 45282

På bakgrunn av vedtak fattet av Miljøverndepartementet i møte den 25.04.95 gir Statens Forurensningstilsyn med dette NIVA tilsagn om inntil kroner 30.000 til dekning av kostnader for å etablere en forskningskontakt innenfor miljøvern mellom NIVA og POLTEGOR i Polen.  
Beløpet skal benyttes i overensstemmelse med de planer som er gitt i søknaden av 19.04.95 og i de generelle kravene satt i dette brevet.

Vi viser til Deres søknad av 19.04.95 der det søkes om støtte på kr. 40.000 for å etablere en forskningskontakt innenfor miljøvern mellom NIVA og POLTEGOR, Polen.

Søknaden ble behandlet av Miljøverndepartementet i møte den 25.04.95, og det ble besluttet å bevilge inntil kroner 30.000 til dekning av kostnader i prosjektet.

Beløpet er innvilget i henhold til søknaden av 19.94.95 og de spesielle vilkår som er satt i dette brevet. Hvis det skulle oppstå vesentlige avvik fra planen må dette meddeles SFT. Tilsagnet kan endres (tilsagnsbeløpet evt. reduseres) eller trekkes tilbake dersom prosjektet blir avbrutt, eller det forøvrig er gitt uriktige eller utilfredstillende opplysninger i forbindelse med søknadsbehandlingen.

Innen 3 måneder etter tilsagn om støtte må mottakeren skriftlig bekrefte at tilsagnet vil bli benyttet og at vilkårene for tilskuddet vil bli oppfylt. Etter denne tid bortfaller tilsagnet, med mindre fristforlengelse er gitt.

Med dette tilsagnet er det ikke tatt stilling til spørsmålet om videre støtte til prosjektet.

Utbetaling skjer mot revisorbekreftet regnskap, hvor det fremgår at kostnadene tilhører prosjektet. Eventuelle a konto utbetalinger skal skje mot fremleggelse av regnskap over påløpte utgifter. For utbetalinger i 1995 bør faktura være SFT i hende før 05.12.95. Godkjente reiser dekkes etter statens regulativ.

Endelig regnskap og sluttrapport sendes inn senest en måned etter at prosjektet er avsluttet. Sluttrapporten skal foreligge på engelsk og i 3 eksemplarer.

Riksrevisjonen har adgang til å kontrollere om tilskuddsmidlene er nyttet etter forutsetningene.

Opplysninger og informasjon som måtte være nødvendig for å evaluere tiltaket må fremskaffes på anmodning.

Prosjektets virksomhet i Øst-Europa forutsettes gjennomført i henhold til regler i angjeldende land.

Miljøvernmyndighetene vil informere om de prosjektene som støttes. Prosjektene vil derfor bli offentlig kjent, med mindre avtale om fortrolighet foreligger.

Med hilsen



Øyvind Schreiner (e.f.)

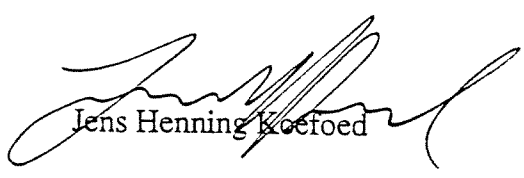

Jens Henning Kjøfoed

Kopi til: Miljøverndepartementet v/Irene Bauer  
Utenriksdepartementet, Øst-Europasekretariatet  
Den norske ambassade i Warszawa.

## **Appendix 2: NIVA Projects in Central and Eastern Europe 1990 - 1996**

## Major Projects in Central and Eastern Europe, 1990-1996

Country/Area:	Project Title:	Client:
<b>Poland</b>	Critical loads of acidity to lakes in the Polish Tatra Mountains	Norwegian Ministry of Environment
	Seminar on strategy for water pollution abatement in view of the Norwegian experience	Norwegian Ministry of Environment
	Upgrading of existing wastewater treatment plant facilities in Poland	Norwegian Ministry of Environment
	Production and testing of aluminium coagulants from the polymer PAC-Sican project	A/S Polymer
	Master and action plan for a chosen catchment area in Poland and Strategy for integrated water supply, wastewater treatment and disposal systems in small communities in Poland	Centre for International University Cooperation Norwegian Ministry of Environment
<b>Czech Republic</b>	Regional plan of environmental priorities for Northern Bohemia, Czech Republic	Czech Ministry of Environment, Norwegian Ministry of Foreign Affairs, the World Bank
	Upgrading of existing wastewater treatment plant facilities in the Czech Republic	Norwegian Ministry of Environment
	Pre-feasibility study of wastewater treatment/management from Zapadoceske Papirny and Ostrov municipalities	Jensen Engineering
	Environmental Impact Assessment of the Odra catchment area and strengthening of water resource management	Norwegian Ministry of Environment
	The quality of the Odra River according to international criteria for classification of water quality	Norwegian Ministry of Environment
	Environmental improvement of areas polluted by metal ore mining	Norwegian Ministry of Environment
	Biomonitoring effects of acid rain using the Czech Score Method	Norwegian Ministry of Environment
	Assessing critical loads of acidity to surface waters in the Czech Republic	Norwegian Ministry of Environment

<b>Country/Area:</b>	<b>Project Title:</b>	<b>Client:</b>
<b>Czech Republic, cont.</b>	Protection of water quality in drinking water reservoirs	Norwegian Ministry of Environment
	Water toxicity testing as related to the protection and improvement of water ecosystems	Norwegian Ministry of Environment
<b>Hungary</b>	Fact finding mission to Hungary	Norwegian Ministry of Foreign Affairs
	Upgrading of existing wastewater treatment plant facilities in Hungary	Norwegian Ministry of Environment
	Development of surface water quality objectives and standards for use related classes at selected watersheds	Norwegian Ministry of Environment
	Development of sewerage systems and wastewater treatment plants in Nograd County, Hungary.	Norwegian Ministry of Foreign Affairs
<b>Russia</b>	Baltic Sea Environment Programme: Pre-feasibility study of the Kaliningrad region and the Pregel River basin	European Bank for Reconstruction and Development (EBRD) and Nordic Investment Bank (NIB)
	Acidification of surface waters, nickel and copper in water and lake sediments in the Soviet-Norwegian border areas	Norwegian Ministry of Environment
	Norwegian - Russian environmental co-operation on the Kola peninsula	Norwegian Ministry of Environment
	A study of phytoplankton and macrophytic in the border river Pasvik on the Kola peninsula	Norwegian Ministry of Environment
	Heavy metal pollution from mining in the Nikel area, Kola peninsula, Russia	Norwegian Ministry of Environment
	Aquaculture co-operation Norway - West Russia	Norwegian Ministry of Foreign Affairs
	Environmental Action Programme for the Kola peninsula, Russia (proposal)	Nordic Environment Finance Corporation (NEFCO), Norwegian Ministry of Foreign Affairs
<b>Latvia</b>	Water quality monitoring and pollution abatement planning in Latvia (proposal)	Norwegian Ministry of Environment
<b>Baltic Sea Area</b>	Baltic Sea Environment Programme: Topical area study for agricultural runoff	European Bank for Reconstruction and Development (EBRD)



## **Appendix 3: Information about Poltegor**

# poltegor instytut

GÓRNICTWO  
ODKRYWKOWE  
OPEN CAST  
MINING

GEOTECHNIKA  
GEOLOGY  
ENGINEERING

UJĘCIA WODNE  
WATER INTAKE

OCHRONA  
ŚRODOWISKA  
ENVIRONMENTAL  
MANAGEMENT

MECHANIZACJA  
MECHANIZATION

AUTOMATYKA  
AUTOMATION

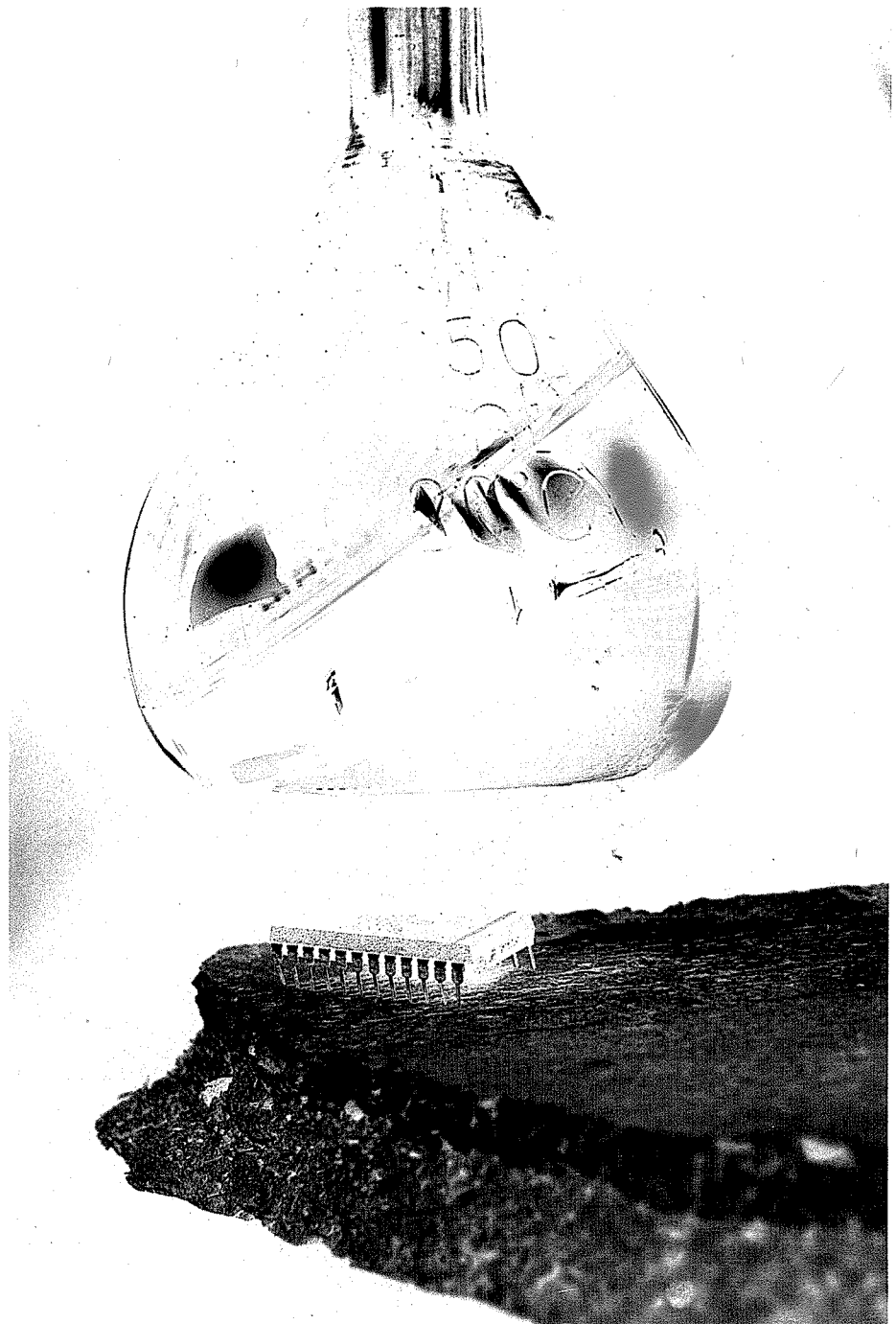

# poltegor-institut

## **makes research for:**

- geology engineering
- hydrogeology engineering
- strain gauge engineering
- noise, vibration and dustiness control
- chemical analysis of water, raw rock material, sewage, soil

## **production of special apparatus:**

- soil probe
- filters for water intakes
- profiled conveyor belts
- hydraulic press for conveyor belt coupling
- shears for steel rope conveyor belts
- for gearbox and bearing diagnostic
- for conveyor output measurements
- for conveyor belt protection
- for bucket wheel excavator control

## **offers original design and production engineering for:**

- deposit facilities, mineral utilization
- attend raw material and waste utilization
- underground and surface water intakes
- mechanization and automation of mining
- light bridges and viaducts
- mechanized equipment for earth movement
- conveyor belt regeneration

## **service for:**

- repairing and coupling of conveyor belts
- cleaning and regeneration of wells
- production of small ton weighing prototypes
- measurements of bridges and steel constructions



## **poltegor-institut**

INSTYTUT GÓRNICTWA ODKRYWKOWEGO  
OPEN CAST MINING INSTITUTE

51-615 WROCŁAW

ul. Parkowa 25

Tel. (071) 48-42-81

Fax 48-43-20 Tlx. 0712409

# SCHEMAT ORGANIZACYJNY

## POLTEGOR - INSTYTUT

### DYREKCJA, ADMINISTRACJA, PRACOWNIE POMOCNICZE

		<b>D</b>	<b>DYREKTOR</b>		<b>RADA NAUKOWA</b>
<b>PF</b>	Sekcja Planowania i Fakturowania			<b>SRN</b> <b>DK</b>	Sekretarz Rady Naukowej Kadry
<b>DG</b>	Dział Techniczno - Gospodarczy				
		<b>DT</b>	<b>ZASTĘPCA DYREKTORA</b>	<b>BP</b>	Informacja Naukowo - Techniczna
<b>FK</b>	Sekcja Finansowo - Księgowa			<b>GO</b>	Redakcja "Górnictwa Odkrywkowego"
<b>EP</b>	Sekcja Ekonomiki Płac	<b>DF</b>	<b>GŁÓWNY KSIĘGOWY</b>	<b>PG</b>	Poligrafia i Archiwum Techniczne

### PRACOWNIE BADAWCZO - ROZWOJOWE I ZAKŁADY TECHNICZNE

<b>NG1</b>	Technologia Odkrywkowa, Eksploatacja, Utylizacja Odpadów i Inżynieria Środowiska	<b>NB1</b>	Technologia Górnicza	<b>NA1</b>	Automatyka Górnicza
		<b>NU1</b>	Utylizacja Kopalni Towarzystających i Surowców Odpadowych	<b>NA2</b>	Mikroprocesorowe Systemy Automatyki
<b>NG2</b>	Geotechnika, Inżynieria i Ochrona Wód Gruntowych	<b>NU2</b>	Ochrona Środowiska i Badania Chemiczne	<b>NA3</b>	Energoelektryka Górnicza
<b>NG3</b>	Geologia Techniczna	<b>NS1</b>	Technologia Wydobywania i Przeróbka Surowców Skalnych	<b>NAB</b>	Diagnostyka Elektroniczna
		<b>NS2</b>	Przeróbka i Wzbogacanie Surowców Skalnych		
<b>NH1</b>	Hydrogeologia i Odwodnienie				
<b>NH2</b>	Prognozowanie Procesów Hydrogeologicznych	<b>NM1</b>	Maszyny Podstawowe	<b>NWM</b>	Prototypy i Urządzenia Eksperymentalne
<b>NC</b>	Geologia	<b>NTr</b>	Urządzenia Transportowe, Dźwigowe i Przenośnikowe	<b>NWT</b>	Technologia i Eksploatacja Taśm

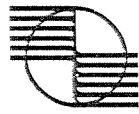

poltegor - instytut

OCHRONA ŚRODOWISKA  
BADANIA CHEMICZNE

ENVIRONMENTAL PROTECTION  
CHEMICAL EXAMINATION



***Prowadzi badania:***

– stopnia skażenia chemicznego gleb, wód powierzchniowych i podziemnych w rejonach eksploatacji odkrywkowej,

– monitoringu wraz z oceną przyczyn i zmian chemizmu wód podziemnych, powierzchniowych, wycieków i spływów w rejonie kopalń odkrywkowych w aspekcie ochrony środowiska,

– dynamiki ługowania zanieczyszczeń z gruntów nadkładowych i popiołów lotnych oraz określenie ich wpływu na środowisko wodne,

– nad zamknięciem obiegów wodnych na drodze sedymentacji z zastosowaniem flokulantów i koagulantów,

– nad wykorzystaniem właściwości sorpcyjnych węgla brunatnego do oczyszczania wód i gruntów.

***Pracownia wyposażona jest między innymi w:***

– spektrometr absorpcji atomowej Perkin-Elmer-Model 3100,

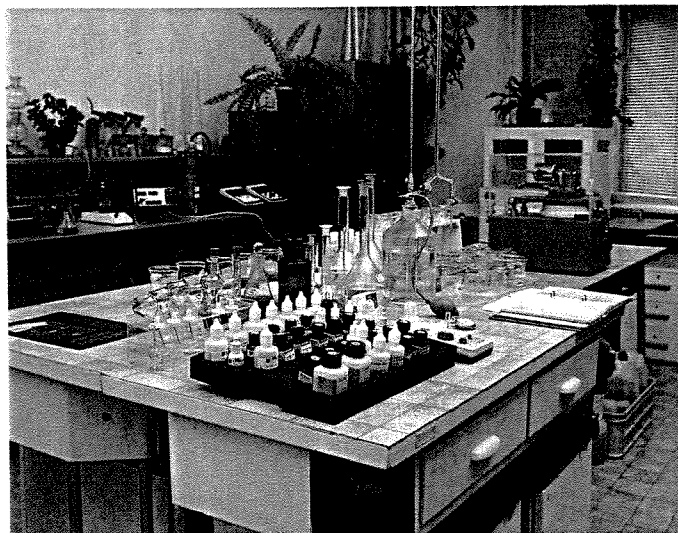

– dwustanowiskowy mineralizator mikrofalowy typ BM-1s/II firmy Plazmatronika,

– polowy zestaw do badań stopnia zanieczyszczenia środowiska firmy Slandi,

– przenośną wieloczujnikową głowicę typ N5057 firmy Meseko,

– specjalne oprogramowanie komputerowe

**ENVIRONMENTAL PROTECTION  
AND CHEMICAL EXAMINATION TEAM**

The team is involved in:

– Evaluation of chemical contamination degree of soils, surface and underground waters within areas of mining operations,

– Monitoring along with the assessment of causes and changes of the chemism of underground and surface waters, effluents and runoffs in the regions of surface mines in view of environmental protection,

– Tests of the dynamics of pollutants leaching from overburden rocks and fly ashes, and estimation of their impact on the water environment,

– Water circulation cut-off by way of sedimentation with use of flocculants and coagulants,

– Making use of sorption features of lignites for water and soil treatment.

***The team has the disposal, among others, of the following equipment:***

– Perkin-Elmer-Model 3100 atomic absorption spectrometer,

– two-station microwave mineralizer type BM-1s/II manufactured by Plazmatronika,

– field testing set for survey of environmental pollution degree, manufactured by Slandi,

– portable multi-detector head type N5057 manufactured by Meseko,

– special computer software.





WYSOKOWYDAJNE I SKUTECZNE  
URZĄDZENIA DO OCZYSZCZANIA ŚCIEKÓW

HIGH DUTY AND EFFECTIVE  
EQUIPMENT FOR SEWAGE TREATMENT PLANTS

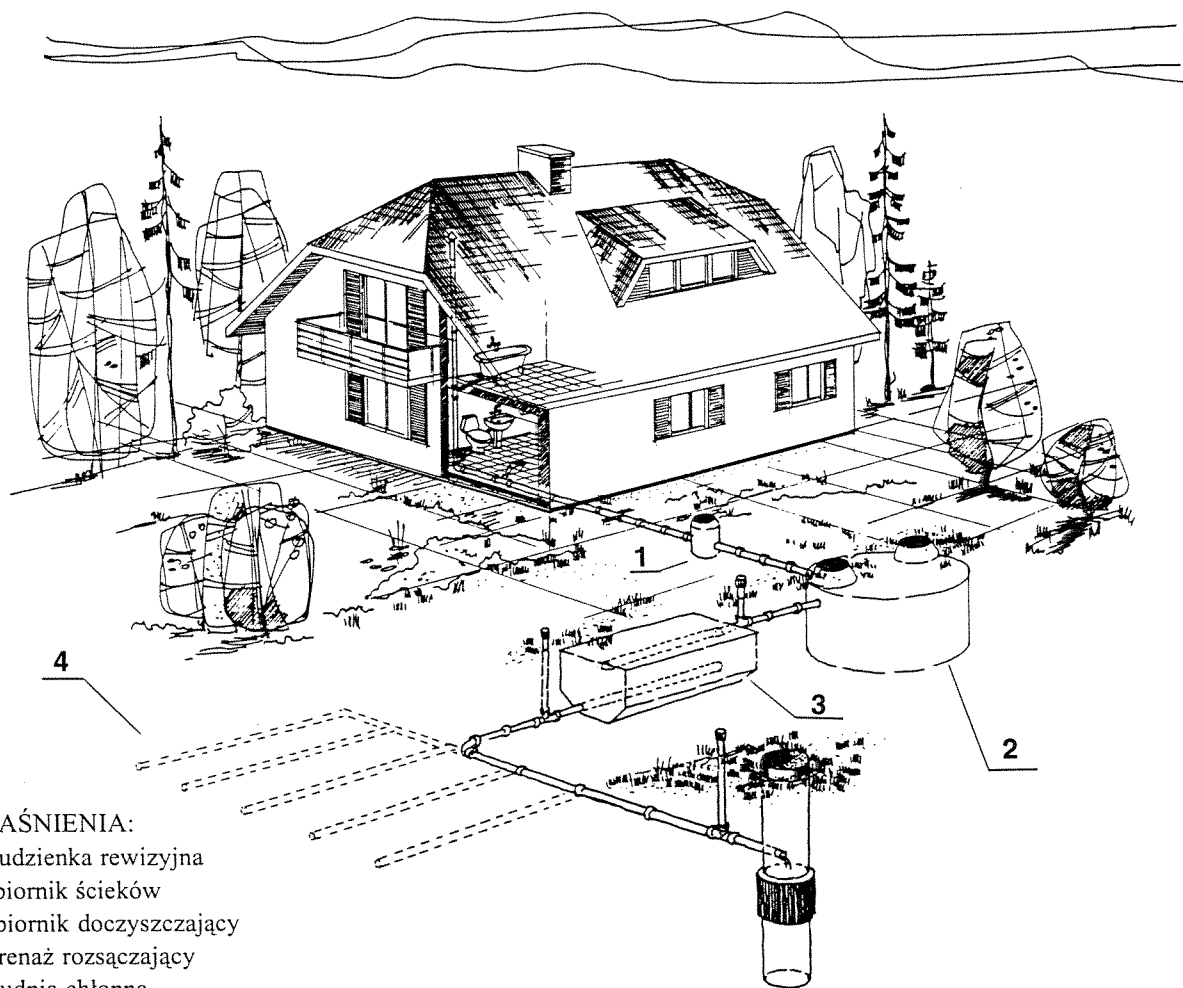

OBJAŚNIENIA:

1. Studzienka rewizyjna
2. Zbiornik ścieków
3. Zbiornik doczyszczający
4. Drenaż rozsączający
5. Studnia chłonna

EXPLANATIONS:

1. Inspection chamber
2. Sewage tank
3. Supplementary treatment well
4. Dissepagement drainage
5. Absorbing well

**NOWA GENERACJA OCZYSZCZALNI ŚCIEKÓW**

**BUDOWA**

Oczyszczalnia ścieków składa się z:

- szczelnych zbiorników (betonowe, metalowe lub z tworzywa sztucznego),
- urządzeń do defosfatacji i denitryfikacji,
- grawitacyjnego lub mechanicznego urządzenia do napowietrzania z zastosowaniem struktur porowatych,
- drenażu rozsączającego,
- studni chłonnych.

Oczyszczalnie przeznaczone są dla: gospodarstw wiejskich, domów wczasowych, zakładów gastronomicznych, rzeźni, ubojni, garbarni, stacji benzynowych, galwanizerni oraz innych użytkowników uciążliwych dla środowiska.

**RENOWACJA SZAMB I OCZYSZCZALNI ŚCIEKÓW**

Poltegor-Instytut posiada rozwiązania techniczne pozwalające na renowację szamb i oczyszczalni ścieków polegające na:

- uszczelnianiu istniejących zbiorników za pomocą injekcji,
- zainstalowaniu nowych wysokowydajnych urządzeń.

**EFEKTYWNOŚĆ OCZYSZCZALNI**

- średnie stężenie BZT-5 w odpływie do 10-20 g O<sub>2</sub>/m<sup>3</sup>,
- średnie stężenie ChZT w odpływie do 100 g O<sub>2</sub>/m<sup>3</sup>,

- średnie stężenie zawiesiny ogólnej w odpływie do 30 g/m<sup>3</sup>,
- średnie stężenie fosforu ogólnego w odpływie 1,5 g P/m<sup>3</sup>,
- średnie stężenie azotu ogólnego w odpływie do 15 g N/m<sup>3</sup>.

Po zrealizowaniu projektu Poltegor-Instytut przeprowadzi na własny koszt badania ścieków (na życzenie inwestora badania mogą obejmować metale ciężkie).

Poltegor-Instytut we własnym zakresie wykonuje operaty wodno-prawne, uzgadnia i wykonuje dokumentację oraz odpłatnie zapewnia serwis urządzeń wraz z okresowymi przeglądami.

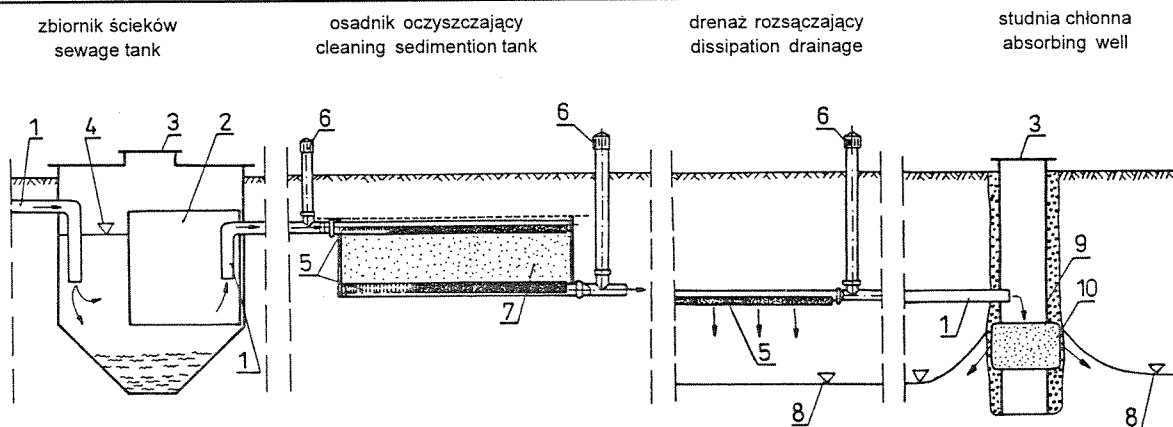

OCZYSZCZALNIA ŚCIEKÓW TYPU POLTEGOR-INSTYTUT  
SEWAGE TREATMENT PLANT OF POLTEGOR-INSTITUTE TYPE

- 1 - rura ściekowa, 2 - przegroda, 3 - właz, 4 - poziom ścieków w zbiorniku, 5 - drenaże prod. IGO Poltegor, 6 - wywietrznik, 7 - struktura porowata z sorbentami naturalnymi, 8 - poziom zwierciadła wody w gruncie, 9 - obudowa studni, 10 - filtr okładzinowy prod. IGO Poltegor
- 1 - sewage pipe, 2 - partition, 3 - manhole, 4 - sewage level in tank, 5 - drains mftd by Poltegor, 6 - ventilator, 7 - porous structure with natural sorbents, 8 - water table level in ground, 9 - well casing, 10 - lining filter mftd by Poltegor

**NEW GENERATION OF SEWAGE TREATMENT PLANT**

**STRUCTURE**

The sewage treatment plant consists of:

- leak-proof reservoirs (cement, metal or plastic ones),
- defosfatation and denitrification equipment,
- gravitation or mechanic device for aeration with the use of porous structures,
- disseepage drainage,
- absorbing wells.

Treatment plants are designed for: farmsteads, summer resort houses, restaurants, slaughterhouses, tanneries, petrol stations, galvanizing plants and other users whose activities are hazardous for the environment.

**RENOVATION OF SEPTIC TANKS AND SEWAGE TREATMENT PLANTS**

Poltegor-Institute possesses technical solutions which make it possible to perform renovation of septic tanks and sewage treatment plants consisting in:

- sealing the existing reservoirs with the injection method,
- installation of new high efficiency equipment.

**EFFECTIVENESS OF SEWAGE TREATMENT PLANT**

- mean concentration of BOD-5 at the outlet up to 10-20 g O<sub>2</sub>/m<sup>3</sup>,
- mean concentration of COD at the

outlet up to 100 g O<sub>2</sub>/m<sup>3</sup>,

- mean concentration of general suspension at the outlet up to 30 g/m<sup>3</sup>,
- mean concentration of general phosphorus at the outlet 1,5 g P/m<sup>3</sup>,
- mean concentration of general nitrogen at the outlet up to 15 g N/m<sup>3</sup>.

Having realized the design Poltegor-Institute will carry out the examinations of sewage at its own charge (upon the customer's order the examinations may include heavy metals).

Poltegor-Institute makes water-legal statements, coordinates and prepares documentation in its own capacity and on condition of payment it provides service for the equipment including periodical overhauls.





**poltegor - instytut**

---

**ZAKŁAD GEOTECHNIKI, INŻYNIERII  
I OCHRONY ŚRODOWISKA**

**GEOTECHNICS, ENGINEERING AND  
ENVIRONMENTAL PROTECTION TEAM**





### WYKONAWSTWO I RENOWACJE OBIEKTÓW MOSTOWYCH

Kompleksowe wykonawstwo obiektów mostowych o oryginalnej konstrukcji charakteryzujących się niskimi kosztami i krótkim cyklem budowy.

Oferowane usługi w zakresie budowy nowych mostów lub obiektów inżynierskich obejmują:

- badania geotechniczne podłoża gruntowego,
- projekt obiektu,
- wykonawstwo konstrukcji stalowej i prefabrykowanej prześleń i nawierzchni mostowych,
- wykonawstwo podpór mostowych,
- montaż konstrukcji,
- wykonawstwo nawierzchni izolacji i prac wykończeniowych,
- wykonanie próbnego obciążenia.

Oferowane usługi w zakresie renowacji elementów istniejących mostów lub obiektów inżynierskich obejmują:

- ekspertyzy i badania stanu technicznego elementów obiektu przeznaczonych do renowacji,
- projekty renowacji,
- wykonanie renowacji obiektów bądź ich części z wykorzystaniem najnowszych technologii i materiałów stosowanych w świecie.

Zrealizowano dotychczas około 150 obiektów z pozytywnym skutkiem technologiczno-użytkowym.

### PRACE BADAWCZE I PROJEKTOWE

Obejmują badania polowe i laboratoryjne, ekspertyzy, projekty wstępne i techniczno-robocze, nadzory autorskie i orzeczenia techniczne.

#### 1. Geotechniczne rozpoznanie podłoża gruntowego i stanu technicznego istniejących obiektów obejmujące:

- płytkie wiercenia mechaniczne i ręczne,
- sondowania statyczne i dynamiczne,
- badania polowe,
- badania laboratoryjne gruntów i wód gruntowych dla potrzeb budownictwa, górnictwa, komunikacji i hydrotechniki,
- badania chemiczne gleb, gruntów i wód,
- określenie warunków posadowienia budowli przemysłowych, inżynierskich, hydrotechnicznych i specjalnych,
- określenie warunków stateczności skarp kopalń odkrywkowych (deformacje, przemieszczenia pionowe i poziome, zagęszczalności gruntów itp.),
- badania wytrzymałościowe obiektów,
- badania stanu technicznego uszkodzonych bądź remontowanych obiektów budowlanych, inżynierskich i hydrotechnicznych.

#### 2. Przeciwdziałanie destruktywnym procesom geotechnicznym, obejmujące:

- stabilizację terenów i obszarów osuwiskowych,
- wzmocnienie podłoża gruntowego pod projektowanymi i istniejącymi budowlami,

### WORKMANSHIP AND RENEWAL OF DESIGNED BRIDGES

Overall project management for originally designed bridge structures characterized by a low cost and short cycle of construction.

The offered services for construction of new bridges or engineering structures include:

- geotechnical survey of subsoil,
- structural design,
- workmanship of steel and prefabricated structures of bridge spans and pavements,
- fabrication of bridge supports,
- structural erection,
- paving, making insulation and finishing work,
- test loading.

The offered services for renewal of the components of existing bridges or engineering structures include:

- expertises and evaluation of technical condition of the components intended for renewal,
- designs for renewal of a structure,
- making renewals of the structures or their components with use of latest techniques of operation and materials world-wide.

About 150 facilities implemented successfully until now.

### RESEARCH AND DESIGN

Including field and laboratory tests, expertises, basic and detail engineering, designer's supervision on site, and technical expert evidence.

#### 1. Geotechnical Exploration of Subsoil and Evaluation of Technical Condition of Existing Facilities including:

- shallow mechanical and hand drillings,
- static and dynamic probing,
- field tests,
- laboratory tests on soils and ground waters for building industry, mining, communications and hydrotechnics,
- chemical examinations of soils, grounds and water,
- determination of conditions for foundation of industrial, engineering, hydrotechnical and special structures,
- determination of conditions for slope stability in surface mines (deformation, vertical and horizontal displacements, compactibility, etc),
- strength tests of structures,
- evaluation of technical condition of damaged or repaired building, engineering and hydrotechnical structures.

#### 2. Prevention of Destructive Geotechnical Processes including:

- ground and land slide stabilization,
- reinforcement of subsoil for designed and existing structures,

- sterowanie cechami nośnymi podłoża gruntowego dla budowli inżynierskich, hydrotechnicznych (wymiana gruntów, stabilizacja podłoża, iniekcja wglębna, petryfikacja elektroosmotyczna itp.),

- inżynierskie wymuszanie poprawy nośności podłoża gruntowego (konstrukcje i urządzenia podpierające, zbrojenie podłoża gruntowego i budowli ziemnych, kotwienie górotworu kotwami rozpięrami lub cięgnami itp.),

- konstrukcje podpierające i wspomagające stateczność (umocnienia skarp, budowle oporowe, gruntowe masywy oporowe.)

- technologiczne sterowanie warunkami stateczności budowli ziemnych (budowa zwałowisk odpadów na podłożu o słabej nośności).

- control of subsoil bearing features for engineering structures and hydrotechnical facilities (ground replacement, subsoil stabilization, deep injection, electro-osmotic petrification, etc.)

- engineering-forced improvement of subsoil bearing capacity (supporting structures and facilities, reinforcement of subsoil and earthen structures, anchorage of rock mass using sprag anchors or tension members, etc.),

- structures to support and to aid stability (revetments of slopes, retaining walls.)

- technology-oriented control of stability conditions of earthen structures (construction of waste disposals on the weak ground).



Most prefabrykowany systemu "Poltegor" (rzeka Świder, nośność 30T, L=80 m). Inwestor - WZDiM - Otwock

### 3. Ochrona środowiska - ochrona gleby i wód gruntowych przed zanieczyszczeniami przemysłowymi obejmująca:

- chemiczne rozpoznanie stopnia skażenia metalami ciężkimi gleby i wód gruntowych,

- przeciwdziałanie zanieczyszczeniom metalami ciężkimi wód powierzchniowych, gruntowych i ujęć wód pitnych z zastosowaniem elektrokinety i mediów neutralizujących,

- neutralizacja oddziaływania utworów skażonych metalami ciężkimi w środowisku gruntowo-wodnym,

- oczyszczanie i utylizacja odpadów popłuczkowych i poflotacyjnych z zastosowaniem elektrokinety i mediów neutralizujących,

- utylizacja odpadów przemysłowych i towarzyszących kopalinom głównym,

- usuwanie odpadów dennych ze zbiorników otwartych i cieków wodnych.

### 3. Environmental Protection - Soil and Ground Water Protection against Industrial Effluents including:

- chemical exploration of soil and ground water contamination by heavy metals,

- prevention of surface water, ground water, drinking water, intake contamination by heavy metals with use of electrokinesis and neutralizing media,

- neutralization of impact of formations contaminated by heavy metals (polluted bottom deposits, industrial wastes, municipal wastes) on the ground and water environment,

- treatment and utilization of washing and floatation tailings with use of electrokinesis and neutralizing media,

- utilization of industrial wastes and those accompanying main minerals,

- removal of bottom deposits from open reservoirs and water-courses.

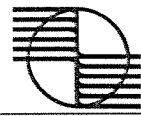

**NOWA GENERACJA WYSOKOWYDAJNYCH  
FILTRÓW STUDZIENNYCH DO UJMOWANIA  
WÓD PODZIEMNYCH**

**NEW GENERATION OF HIGH EFFICIENCY  
WELL FILTERS FOR UNDERGROUND  
WATER INTAKES**



**NOWA GENERACJA WYSOKOWYDAJNYCH  
FILTRÓW STUDZIENNYCH DO UJMOWANIA  
WÓD PODZIEMNYCH**

W nowej konstrukcji elementem filtrującym jest specjalna przepuszczalna okładzina ze struktury porowatej nasuwana na szkielet np. rurowy o dużych otworach perforacji.

**NEW GENERATION OF HIGH EFFICIENCY  
WELL FILTERS FOR UNDERGROUND  
WATER INTAKES**

In the new design the filtration element is in the form of specially permeable lining of porous structure put on the framework e.g. pipe one with big perforation holes.

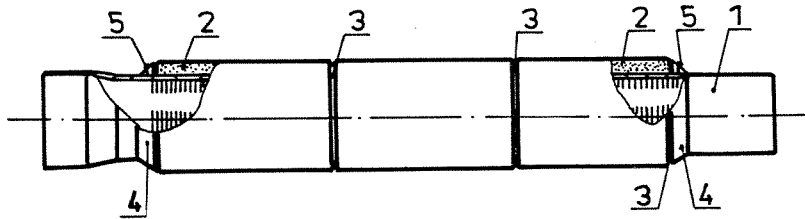

Rys.1. Filtr okładzinowy

1 - szkielet filtrowy (rura), 2 - okładzina ze struktury porowatej  
3 - uszczelka gumowa, 4 - pierścień aluminiowy, 5 - śruba

Fig.1. Lining filter

1 - filter framework ( pipe), 2 - lining of porous structure  
3 - rubber seal, 4 - aluminium ring, 5 - screw

Elementy filtracyjne (w odcinkach np. jednometrowych) nasuwane na perforowany szkielet umożliwiają właściwy dobór struktury porowatej w zależności od granulacji warstwy filtrowej - rys.2.

**WARUNKI FILTRACJI**

Z przeprowadzonych badań laboratoryjnych i terenowych wynika, że *nowa generacja wysokowydajnych filtrów do ujmowania wód podziemnych* posiada dwukrotnie większą sprawność w porównaniu do dotychczas stosowanych (siatkowych, z okładziną żwirową naklejaną na szkielet zespolony, z luźną obsypką).

**PARAMETRY HYDRAULICZNE**

W porównaniu do innych typów filtrów uzyskiwane wydajności przepływu wody przy stosowaniu *filtrów nowej generacji* są dwukrotnie większe przy dwukrotnie mniejszej depresji.

W wyniku przeprowadzonych badań i pomiarów określono wydajność w zależności od granulacji żwiru zastosowanego w okładzinach:

Granulacja okładzin żwirowych (średnica żwiru D) [m]	Wydajność Q z 1 m <sup>2</sup> powierzchni filtra [m <sup>3</sup> /s]
$(0,8 \div 1,2) \cdot 10^{-3}$	$1,2 \cdot 10^{-3}$
$(1,2 \div 2,0) \cdot 10^{-3}$	$3,2 \cdot 10^{-3}$
$(2,0 \div 3,0) \cdot 10^{-3}$	$6,6 \cdot 10^{-3}$
$(3,0 \div 5,0) \cdot 10^{-3}$	$8,2 \cdot 10^{-3}$
$(5,0 \div 7,0) \cdot 10^{-3}$	$15,0 \cdot 10^{-3}$
$(7,0 \div 10,0) \cdot 10^{-3}$	$21,6 \cdot 10^{-3}$

**PARAMETRY WYTRZYMAŁOŚCIOWE**

*Fitry okładzinowe nowej generacji* są wytrzymałe na ciśnienia występujące przy dużych depresjach oraz podczas czyszczenia studni. Doświadczalnie potwierdzono ich dużą wytrzymałość np. w studniach odwodnieniowych KWB Bełchatów o głębokości 350 m.

**PROGRAM PRODUKCJI**

Poltegor-Instytut produkuje okładziny filtracyjne dla rur PCW o średnicach  $(110, 160, 225, 280, 315) \cdot 10^{-3}$  oraz dla rur stalowych o średnicach 7 5/8", 9 5/8", i 11 3/4".

Wszystkie materiały do produkcji filtrów posiadają atesty PZH zezwalające ich stosowanie do ujmowania wód pitnych.

Filtration elements (e.g. one meter long) drawn over perforated framework make it possible to select appropriate porous structure in accordance with granulation of the filtered layer - fig. 2.

**FILTRATION CONDITIONS**

From the conducted laboratory and field examination it results that *new generation of high efficiency filters for underground water intakes* has over twice a big efficiency if compared with the one used so far (netlike ones, ones with gravel lining glued on the combined frame, with loose filling).

**HYDRAULIC PARAMETERS**

When compared with other types of filters, the obtained efficiency of water flow having applied *new generation filters*, is twice as big with twice as small depression.

In consequence of the performed examinations and measurements the efficiency has been established according to granulation of the gravel used in linings :

Gravel lining granulation	Efficiency Q from 1 m <sup>2</sup> of the filter area [m <sup>3</sup> /s]
$(0,8 \div 1,2) \cdot 10^{-3}$	$1,2 \cdot 10^{-3}$
$(1,2 \div 2,0) \cdot 10^{-3}$	$3,2 \cdot 10^{-3}$
$(2,0 \div 3,0) \cdot 10^{-3}$	$6,6 \cdot 10^{-3}$
$(3,0 \div 5,0) \cdot 10^{-3}$	$8,2 \cdot 10^{-3}$
$(5,0 \div 7,0) \cdot 10^{-3}$	$15,0 \cdot 10^{-3}$
$(7,0 \div 10,0) \cdot 10^{-3}$	$21,6 \cdot 10^{-3}$

**STRENGTH PARAMETERS**

*New generation linnig filters* are resistant to pressure occurring at big depressions and during the well cleaning. Their high resistance has been experimentally confirmed e.g. in 350 m deep dewatering wells of the Bełchatów Lignite Mine.

**PRODUCTION PROGRAMME**

Poltegor-Institute manufactures filtration linings for PVC pipes of the diameter  $(110, 160, 225, 280, 315) \cdot 10^{-3}$  and for steel pipes of the diameters : 7 5/8", 9 5/8" and 11 3/4".

All the materials for the filter production possess PZH certificate enabling to use them in the drinking water intakes.

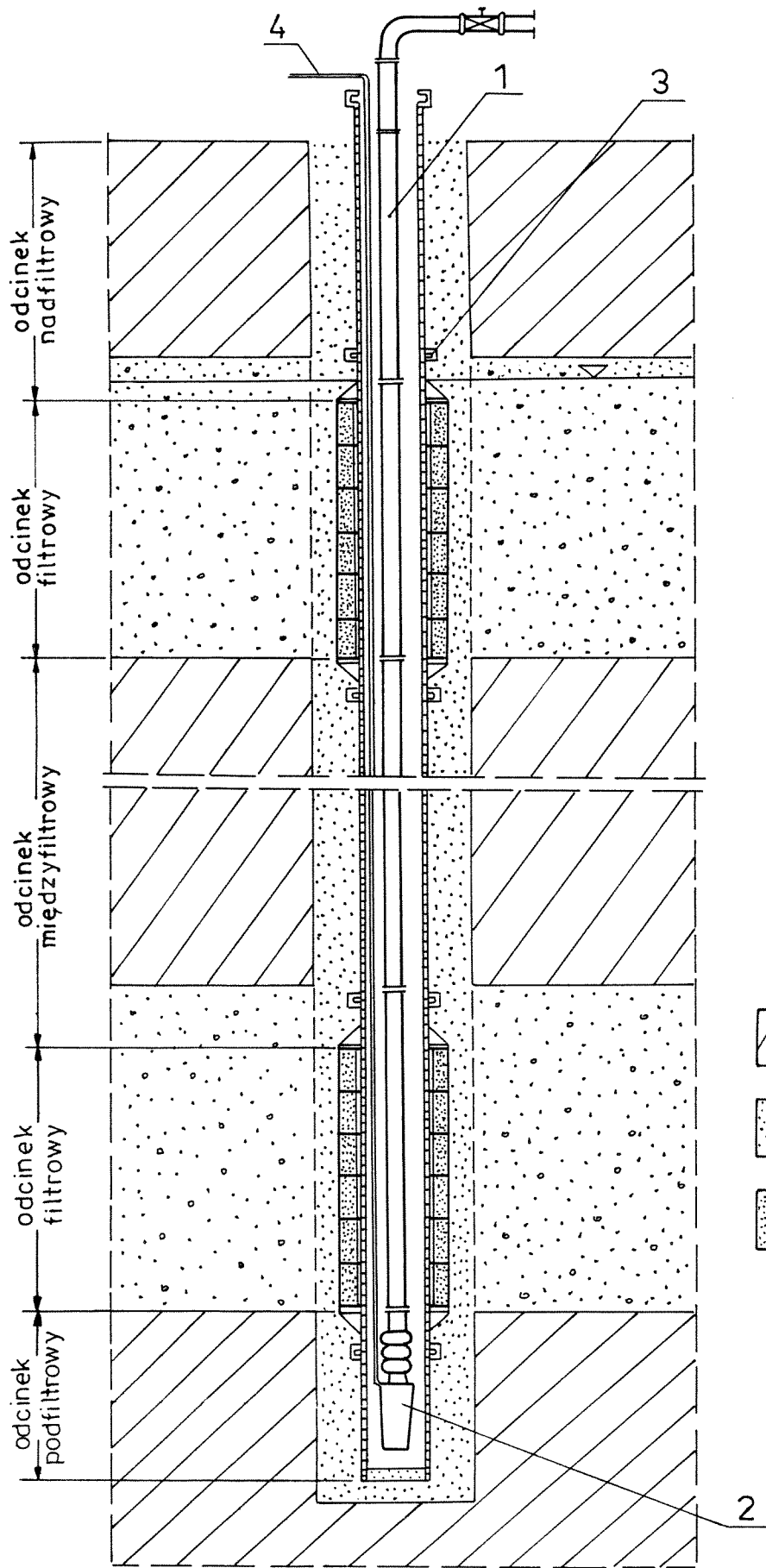

 - utwory nieprzepuszczalne  
- impermeable beds

 - warstwa wodonośna  
- water bearing layer

 - obsypka  
- packing

1 - rurociąg tłoczny  
delivery pipeline

2 - pompa  
pump

3 - połączenie kołnierzowe  
flange joint

4 - kabel zasilający  
feeder cable

Rys.2. Schemat zabudowy kolumny filtrowej z okładziną nasuwaną  
Fig.2. Scheme for installation of filter string with slide-over lining

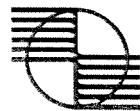

OBLICZENIA HYDROGEOLOGICZNE  
METODĄ NUMERYCZNĄ

HYDROGEOLOGICAL COMPUTATIONS  
BY NUMERICAL METHOD

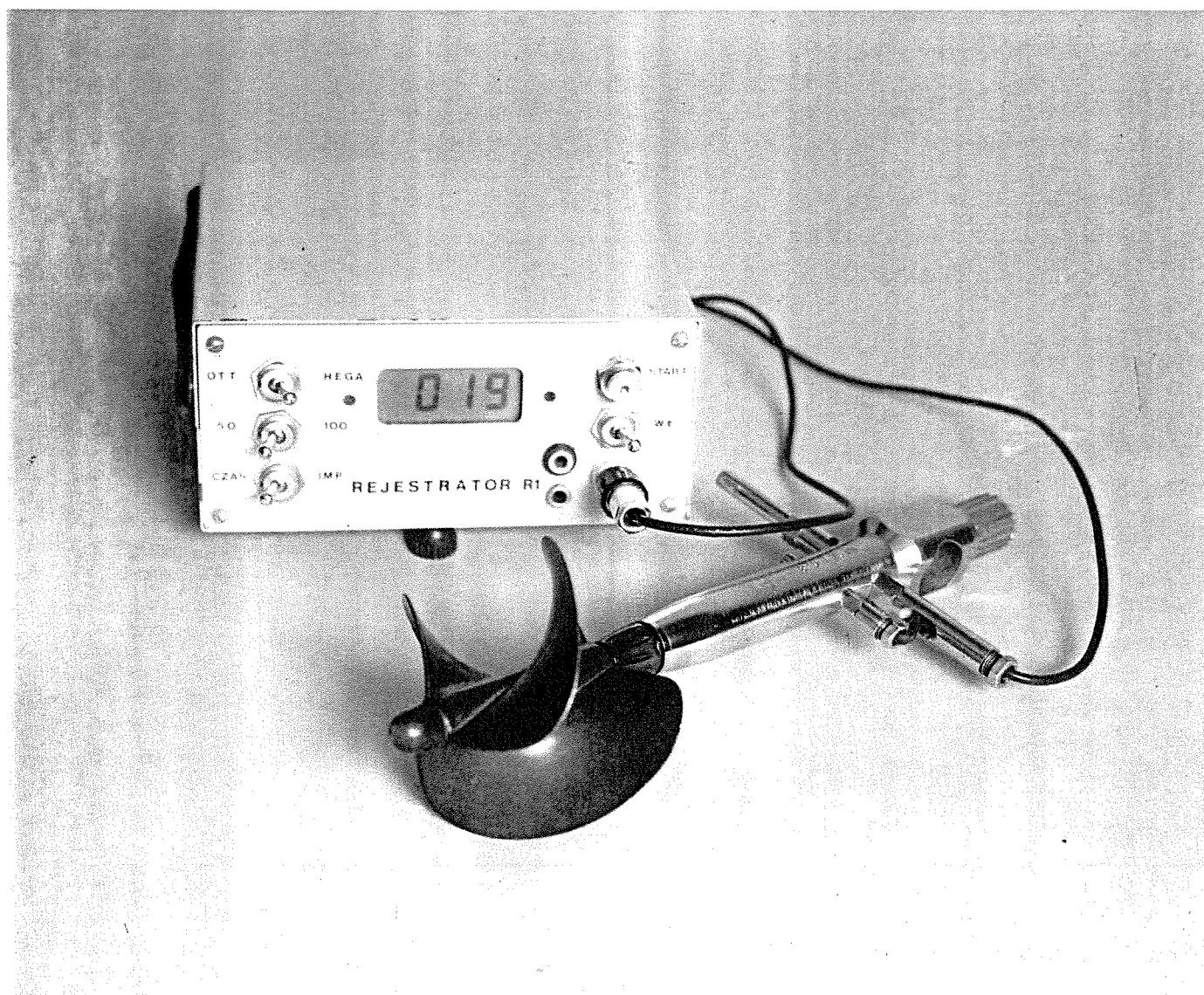



**OBLICZENIA HYDROGEOLOGICZNE  
METODĄ NUMERYCZNĄ**

Numeryczne modelowanie procesów hydrogeologicznych opiera się na matematycznej metodzie elementów skończonych (MES) i programie liczącym FKWH. Według MES pole filtracji w planie (rys. A) dzieli się na sieć trójkątów, których wierzchołki (węzły) służą dyskretnemu odwzorowaniu ciągłego pola filtracji. Model numeryczny tworzy się na bazie węzłów siatki trójkątnej. W węzłach zapisuje się głęboką budowę geologiczną, poziomy ciśnienia wód podziemnych, parametry filtracyjne. Węzły zastępują również w modelu rzeczywiste obiekty drenażowe np. studnie. Program liczący umożliwia modelowanie wielopoziomowych kompleksów wodonośnych niezależnych od siebie (rys. B) lub współdziałających ze sobą przez kontakty hydrauliczne. Możliwe jest liczenie wydajności pojedynczych studni, grup studni i całych barier, depresji w studniach i w polu filtracji, ucieczek wody z rzek, stawów, zbiorników wodnych i osadników. Dopływy wody do studni mogą być rozdzielone na poszczególne poziomy wodonośne.

**HYDROGEOLOGICAL COMPUTATIONS  
BY NUMERICAL METHOD**

The numerical modelling of hydrogeological processes is based on the mathematical finite-element method (MES) and computing software FKWH. According to MES the filtration area in plane (drg. A) is divided into a network of triangles whose vertexes (joints) are used to a discrete representation of the continuous filtration area. The numerical model is created on the basis of triangular network joints. The geological structure, underground water pressure levels, seepage features are recorded at the joints. The joints replace also real drainage facilities in the model, e.g. wells. The computing software allows to model multi-level aquifer complexes, which are independent one from the other (drg. B) or are interrelated one with the other via hydraulic contacts. It is possible to compute yields of individual wells, well groups and entire well barriers, draw-down in wells and within filtration area, water escapes from rivers, lakes, water reservoirs and sedimentation basins. The water inflows to the wells can be separated in individual aquifers.

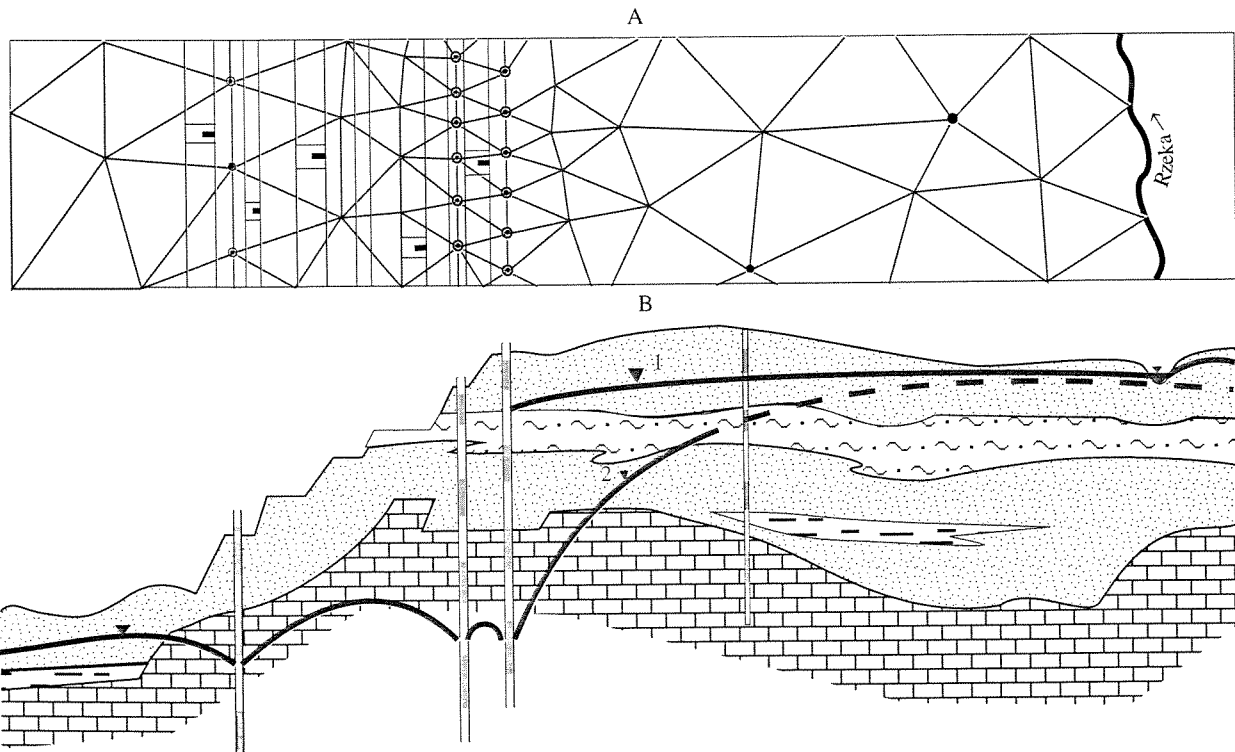

Fragment modelowanej przestrzeni filtracji  
Part view of modelled filtration space  
A - w planie, B - w przekroju  
A - in plane, B- in section



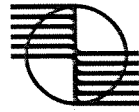

PRACOWNIA CYFROWEGO MODELOWANIA  
WARUNKÓW ZŁOŻOWYCH

DIGITAL BEDDING SIMULATION TEAM

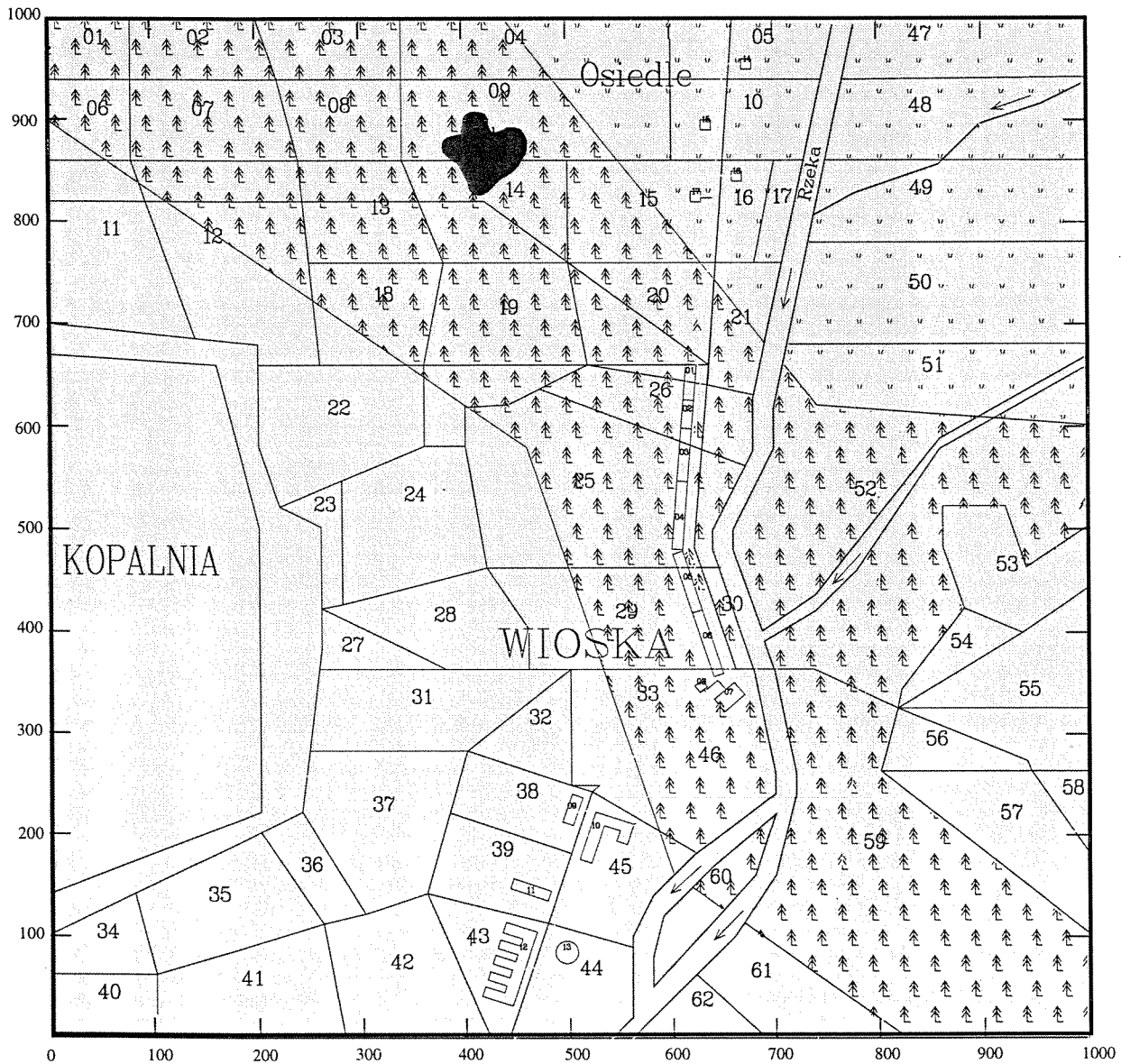



Pracownia od dwudziestu lat prowadzi badania naukowe i prace usługowe z zakresu geologii złożowej.

Naszymi największymi atutami są:

- posiadanie Baz Danych Geologicznych (BDG) dla wszystkich polskich złóż węgla brunatnego,
- szybkie przetwarzanie danych ze zbiorów BDG i innych zbiorów tworzonych poza bazą, z uwzględnieniem geostatystyki,
- modelowanie warunków złożowych (grafika 2 i 3-wymiarowa),
- automatyczne opracowywanie map i przekrojów geologicznych, jakościowych oraz hydrogeologicznych łącznie z zafiltrowaniem otworów.

Posiadamy najnowocześniejszy sprzęt komputerowy (stacje robocze firmy Silicon Graphics i Intergraph) pracujący w sieci Unix'a z podłączonym digitalizatorem i ploterem formatu A0.

The Digital Bedding Simulation Team has been involved for twenty years in the scientific research and service work in area of the geology of mineral deposits.

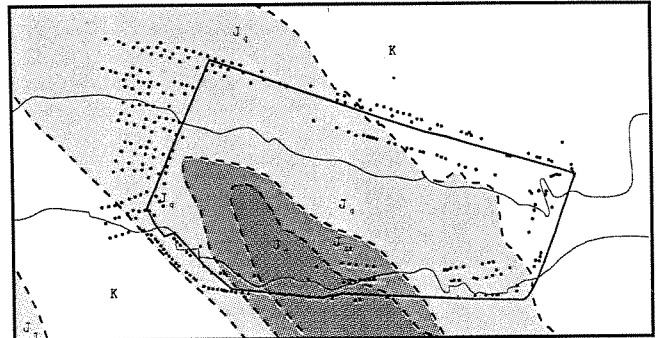

Our best trump cards are as follows:

- possession of Geological Data Bases (GDBs) for all Polish lignite basins,
- quick processing of data from GDB's files and other files created outside the base with special reference to the geostatistics,
- bedding simulation (two- and three-dimensional graphics),
- automatic preparing of maps geological, qualitative and hydrogeological sections including filters to be provided in holes.

We are in possession of latest hardware (workstations Silicon Graphics and Intergraph) operated in the Unix network with connected digitizer and A0 format plotter.

Having the disposal of our own software and Datamine and Intergraph systems, we provide best quality of work in the following areas: geology, geodesy, mining, environmental protection, spatial planning.



Dysponując oprogramowaniem własnym oraz systemami Datamine i Intergraph, zapewniamy najwyższą jakość prac w dziedzinach: geologia, geodezja, górnictwo, ochrona środowiska, planowanie przestrzenne.

POLTEGOR-INSTYTUT

DIGITAL BEDDING SIMULATION TEAM

ul. Parkowa 25, 51-616 Wrocław, Poland,  
phone no. 484 281, fax 484 320, tlx 071 2409

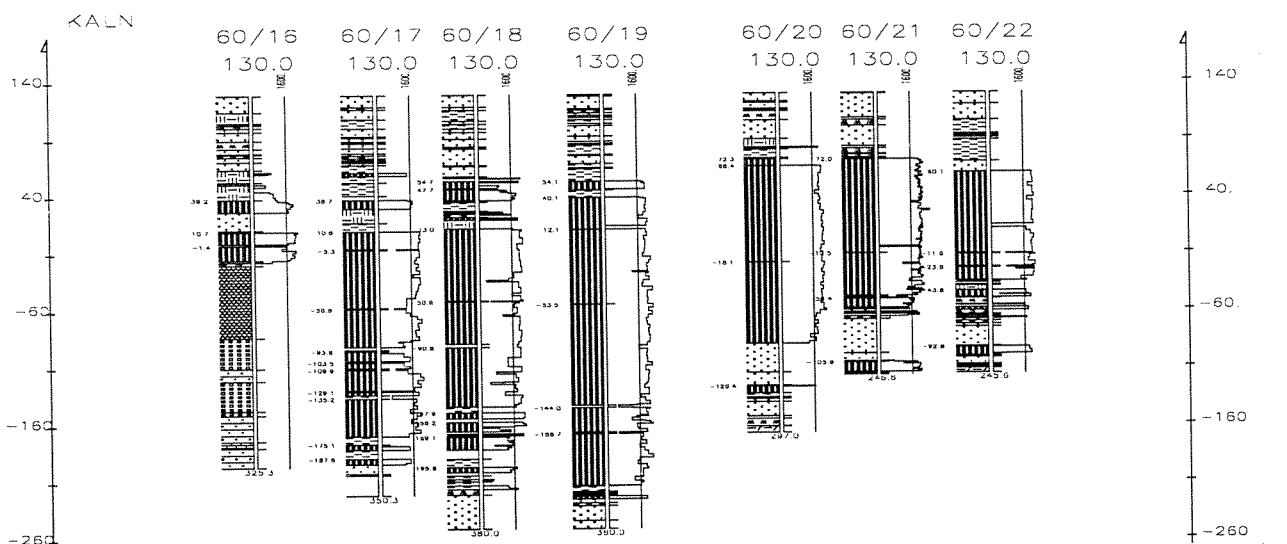

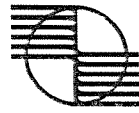

**poltegor - instytut**

---

# NADZÓR I STEROWANIE CIĄGU PRZENOŚNIKÓW TAŚMOWYCH SUPERVISION AND CONTROL OF BELT CONVEYOR FLIGHT





#### INTENDED USE AND DESIGN

The system is designed for the supervision and control of the belt conveyor flight(s) in opencast mines. The system is composed of the dispatcher's station and local control systems of each conveyor which are combined with one another by a network of information exchange.

The station as well as control systems are realized on freely programmed modular controllers TSX 7 manufactured by Telemecanique. The structure of the system is presented below.

Dispatcher's station consists of controller, two control desks with 12 inch colour display units and modules playing additional functions such as acoustic signalling, efficiency measurements, etc. and modules realizing transmission to and from conveyor flight.

Each of the controllers within conveyor flight is equipped with identical set of controller TSX7 installed in electric switching station and alphanumeric terminal XBT-A installed in the operator's control desk. In the electric switching station there are two circuits 6 kV~, 500V~, 220V~ and installation operating such circuits as transformers, cut-outs and safety devices, power contactors of starter control, etc.

The controller TSX 7 realizes all control, checking, and measuring functions connected with conveyor operation. The state of contact circuits of the conveyor system is checked with input modules 220V~, and power contactors switching on individual drives are controlled directly from 220 V~ outputs controller.

Continuous parameters such as temperature of driving elements, load current value, force stretching the belt are introduced to the controller by modules of specialized functions.

Rotational speeds of the driving unit and belt are checked by impulse sensors connected directly with modules of specialized functions.

The controller is also equipped with module of information ex-

change with the dispatcher's station via modem connected with two-paired telephone lines.

For local control of the conveyor, checking its parameters and setting required values the controller is equipped with XBT-A terminal where successive required parameters are read out or setup.

#### PRINCIPLE OF OPERATION

The access to information and control in the dispatcher's station is realized through operator's control desk equipped with colour display unit and functional keyboard built-in in the control desk. One control desk is designed for the visualization of the flight condition, while the other one - for detailed information about the conditions of individual conveyors. The information about the conveyor conditions and controlling signals to the conveyors are transmitted from and to the dispatcher's station by two-paired telephone line with modems in UNITELWAY report.

The visualization is conducted in the form of chosen screens possessing:

- the states of the conveyor operation distinguished with the colours,
- measured values in digital form or with bargraph columns,
- required values in digital form,
- reports about the states of operation and breakdown type.

The access to information and controls on the conveyor is realized with the terminal XBT-A equipped with the push-buttons START, STOP, keys of calling measured and required values etc. The information in the form of verbal message or measured digital value is then displayed on 16 character display unit.

#### VISUALIZATION AND CONTROL

Visualization is conducted in the form of selected screens containing:

- the states of the conveyor operation distinguished with colours
- measured values in digital form or with bargraph columns,
- required values in the digital form,
- reports about the states of operation and breakdown type in the form of messages.

On the screens in the control desk giving the conveyor parameters it is possible to obtain in succession:

- the conveyor state, - temperature, - belt slip,
- the starter state, function blocking, - parameter change, TSX controllers.

In general the values given below are shown on the individual screens for each conveyor:

- basic operation states - 11 units
- values measured on the conveyor - 44 units
- alarms in the control system of the conveyor - 70 units
- blockable control functions - 50 units
- controlled parameter setup - 15 units

Remote control is possible with the use of the push-buttons directly from the control desk where successively started conveyors are visualized on the display unit.

Control of an individual conveyor in the flight can be realized in a test locally (from the terminal) and remotely from the dispatcher's station. During conveyor control and operation the following functions are realized:

- control of the start-up in the function of time or speed,
- control of belt slip and sway,
- asymmetry control,

- blocking of successive start-ups,
- control of engine, transmission, drum bearings and TSX cubicle temperatures,
- interlocking due to receiving conveyor,
- control and signalling of conveyor belts, belt stretching.

The messages are given at the conveyor terminal and they are analogous to the ones from the dispatcher's control desk with the difference that they are in the verbal form for each individual message. In order to establish all messages it is necessary to adopt the viewing principle, whereas the access to the function blocking and set-up of controlled parameters at the terminal are possible having given the blocking entry which is known only by specialized service staff.

#### EQUIPMENT CONFIGURATION AND SOFTWARE

POLTEGOR-INSTYTUT,  
SECTION OF MICROCOMPUTER AUTOMATIC  
CONTROL SYSTEMS  
ul. Parkowa 25, 51-616 Wrocław, Poland,  
phone no. 484 281, fax 484 320, tlx 071 2409

#### APPLICATION

Lignite Mine KONIN 1992



poltegor - instytut

---

ZAKŁAD TECHNOLOGII I EKSPLOATACJI  
TAŚM PRZENOŚNIKOWYCH

SECTION OF TECHNOLOGY AND  
EXPLOITATION OF CONVEYOR BELTS

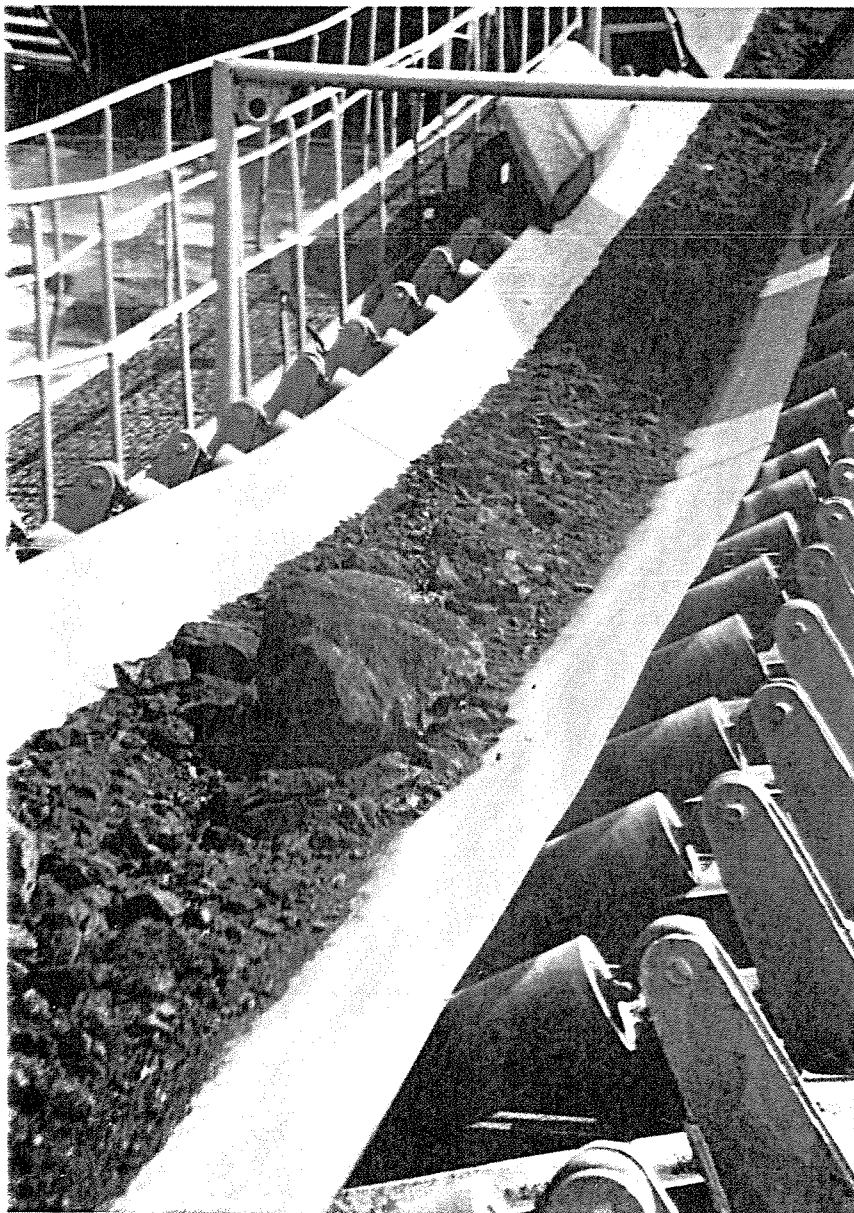



**BADANIA, ŁĄCZENIE  
I KONSTRUKCJE SPECJALNE TAŚM  
PRZENOŚNIKOWYCH**

W ciągu czterdziestu lat prac związanych z projektowaniem, badaniami i eksploatacją przenośników taśmowych zebrano w Poltegorze-Instytucie bogate doświadczenia, prowadzące do rozwoju szeregu specjalistycznych zespołów i pracowni. Przenośniki taśmowe o szerokim wachlarzu różnorodnych konstrukcji, osiągające wysokie wydajności, stały się jedną ze specjalizacji Poltegoru i w tej dziedzinie ma on czołową pozycję, uznaną nie tylko w kraju, ale także za granicą. Ponieważ w problematyce przenośników sprawy taśm, tak ze względu na wysokie koszty jak i wymogi eksploatacyjne, stanowią jedno z najważniejszych zagadnień, więc są one przedmiotem szczególnego zainteresowania Poltegoru.

**BADANIA I DOBÓR TAŚM**

Kadra doświadczonych inżynierów, wyposażona w odpowiednie laboratoria, może podejmować specjalistyczne badania i ekspertyzy wszystkich typów i rodzajów taśm przenośnikowych o dowolnej szerokości. Przedmiotem badań mogą być m.in.:

- właściwości wymagane przez normy państwowe np. PN, DIN, GOST oraz międzynarodowe ISO,
- właściwości specjalne nie objęte normami,
- wartość użytkowa taśm,

- przydatność taśm do pracy w specjalnych warunkach np. w podwyższonych temperaturach,
- dobór taśm dla określonych przenośników i warunków eksploatacyjnych,
- przydatność taśm do regeneracji.

**TECHNOLOGIE ŁĄCZENIA I NAPRAWY  
TAŚM**

Poltegor-Instytut jako jedyny w kraju ośrodek dysponuje wieloletnim doświadczeniem, a także specjalnymi urządzeniami niezbędnymi do opracowywania doboru i wdrażania technologii łączenia i napraw taśm:

- o różnorodnej konstrukcji (np. wieloprzekładkowych, z przekładkami ochronnymi "breaker", z okładkami profilowanymi, z progami, skrzynkowych, typu FLEXOWELL, kordowych, z linkami stalowymi, także w odmianie FLEXIMAT oraz z PCV),
- licznych rodzajów (np. zwykłych, trudnozapalnych, odpornych na ciepło),
- wybranymi metodami (wulkanizacja na zimno lub gorąco, przy użyciu krajowych lub zagranicznych materiałów wulkanizacyjnych),
- w różnych warunkach atmosferycznych i klimatycznych (łącznie z tropikiem),
- różnych typów przenośników uwzględniając wznios, wysokie obciążenia, właściwości nosiwa itp.

**SECTION OF TECHNOLOGY AND EXPLOITATION OF CONVEYOR BELTS**

**EXAMINATIONS, JOINTING AND SPECIAL  
CONSTRUCTIONS OF CONVEYOR BELTS**

For the forty years of conducting the activities connected with designing, examination and exploitation of the conveyor belts in Poltegor-Institute much experience has been obtained giving rise to the development of many specialized teams (units) and workshops.. Belt conveyors of a great variety of construction and high efficiency has become one of Poltegor's specializations and its leading position is recognized not only in Poland but also abroad. Since the problems connected with belts due to the high costs and exploitation requirements constitute one of the most important questions, thus they are the subject matter of a special interest of Poltegor..

**EXAMINATION AND SELECTION OF BELTS**

The team of qualified engineers having laboratories with appropriate equipment at their disposal can undertake specialistic examinations and expertise of all types and sorts of conveyor belts of any width. The subject matter of the examinations can be :

- properties required by national standards e.g. PN, DIN, GOST and international standards ISO,
- special properties not regulated by the standards,
- usability value of the belts,
- suitability of the belts for the operation in special conditions e.g. higher temperatures,

- selection of belts for definite conveyors and operating conditions,
- belt usability for regeneration

**TECHNOLOGIES OF BELT JOINTING  
AND REPAIRS**

Poltegor - Institute as the exclusive centre in Poland has many year experience as well as special equipment indispensable for the determination of the selection and application of technologies of belt splicing and repairs :

- of a versatile constructions ( e.g. multi-ply , with protective plies " breakers", with formed sheets, with box sills, ELEXOWELL type, cord, with steel cords, and also in the FLEXIMAT variation and PCV).,
- different types ( e.g ordinary ones, heat resistant , non-flammable),
- chosen methods ( cold and hot temperature vulcanization, with the use of Polish or foreign vulcanization materials),
- in different weather and climate conditions ( including tropics),
- different types of conveyors taking into account lift, high load, properties of the carried material, etc.,
- using appropriate vulcanization materials.

In each case it is very significant to choose the optimum technology of belt jointing or repair taking into consideration working conditions, type of belt, assumed durability



- przy zastosowaniu odpowiednich materiałów wulkanizacyjnych.

W każdym przypadku, bardzo istotnym czynnikiem jest wybór optymalnej technologii łączenia lub napraw taśm - uwzględniający warunki pracy, rodzaj taśmy, założoną trwałość i niezawodność oraz czas wykonania. Z powodu znacznych różnic zarówno w nakładach finansowych jak i w niezbędnym wyposażeniu w sprzęt wulkanizacyjny, kwestie łączenia w pełni zasługują na najwyższą uwagę i powierzenie decyzji wyspecjalizowanym placówkom.

#### DORADZTWO, ORGANIZACJA I SZKOLENIE SŁUŻB WULKANIZACYJNYCH

Wykorzystując swoje wieloletnie doświadczenia Poltegor-Instytut prowadzi poradnictwo oraz wykonuje projekty (uwzględniające indywidualne warunki kontrahentów) w zakresie:

- gospodarki magazynowej taśmami z uwzględnieniem typizacji eksploatowanych taśm,
- gospodarki materiałami wulkanizacyjnymi,
- doboru, kompletowania sprzętu i urządzeń wulkanizacyjnych do przyjętych technologii łączenia taśm,
- organizacji służb wulkanizacyjnych,
- szkolenia zawodowego w zakresie technologii łączenia taśm tkaninowo-gumowych i z linkami stalowymi oraz obsługi sprzętu wulkanizacyjnego.

#### PRODUKCJA DOŚWIADCZALNA I USŁUGI TECHNICZNE

W oparciu o krajowe surowce i materiały Poltegor-Instytut produkuje taśmy specjalne stosowane w przenośnikach pracujących pod zwiększonym kątem wzniosu:

- taśmy z progami typu U - do materiałów sypkich opakowanych np. w workach, a stosowane powszechnie w przemyśle cukrowniczym, zbożowym itp.,
- taśmy z progami typu V - do transportu piasku, kruszyw i innych materiałów o granulacji od 0 do 50 mm,
- taśmy z progami dwudzielnymi - do transportu kruszyw, ziemiopłodów itp. (przy większych kątach wzniosu),
- taśmy profilowane do separatorów do szerokości 2250 mm, rowokoparek,
- inne wg wymagań użytkowników.

Ponadto wykonuje dokumentację technologiczną, oprządkowanie, a także prototypy elementów gumowych, metalowo-gumowych oraz tkaninowo-gumowych, m.in.:

- wkładki sprężyste od sprężel, uszczelnienia, membrany gumowe i tkaninowo-gumowe, zderzaki, amortyzatory układu zawieszenia do kopalnianych wozów samowyładowczych typu WS-8.

Innym rodzajem działalności są usługi techniczne w zakresie wykonywania połączeń i napraw taśm przenośnikowych, a także oklejania bębnow okładzinami gumowymi w pracowni lub u użytkownika. Łączenie, a także naprawy taśm tkaninowo-gumowych i taśm z linkami stalowymi

and reliability and the operation time. The questions connected with jointing deserve special attention due to considerable differences both in finance costs as well as indispensable vulcanization equipment, thus they should be handed over to specialized decision making organizations.

#### CONSULTING, ORGANIZATION AND VULCANIZATION STAFF TRAINING

Making use of many years' experience Poltegor-Institute conducts consulting activities and makes designs (taking into consideration individual customers' requirements) in the field:

- belt stock management (taking into account type of belts in use),
- vulcanization materials management,
- selection, completion of vulcanization equipment and appliances for the adopted technologies of belt jointing,
- organization of vulcanization services,
- professional training in the field of jointing of fabric-rubber belts and the ones with steel cords and vulcanization equipment service as well.

#### EXPERIMENTAL PRODUCTION AND TECHNICAL SERVICES

On the basis of Polish raw materials Poltegor-Institute manufactures special belts applied in the conveyors operating under an increased lift angle conditions:

- belts with U-type sills for loose materials packed e.g. in bags, used widely in sugar and cereals industries, etc.,

- belts with V-type sills for the transportation of sand, aggregate and other materials of 0 to 50 mm granulation,
- belts with two-step sills for the transportation of aggregate and agricultural produce (at higher lift angle),
- formed belts for max 2250 mm separators, trench excavators,
- others according to the customers' requirements.

Moreover it prepares technological documentation, instrumentation as well as prototypes of rubber, metal-rubber and fabric-rubber elements, among others:

- spring insert (pad) from the clutches,
- sealing (packing),
- rubber and fabric-rubber membranes,
- fenders,
- shock absorbers of the suspension system for mine self-dumping cars WS-8.

Technical services in the range of conveyor belt jointing and repairs as well as coating drums with linings represent other type of Poltegor activities. They are conducted on the spot of the defect, in the workshop or at the consumer's. Jointing as well as repairs of fabric-rubber belts and belts with steel cords are conducted for all types, classes and widths with the method of cold and hot vulcanization, using own equipment and vulcanization materials. Modern hydraulic vulcanization presses are used for hot jointing and it is possible to splice 650 to 2250 mm wide belts. Rendered services, as it is shown in practice, are especially useful in the investments (first jointing), at modernization, and belt exchange on the conveyors also in emergency situations.



wykonuje się dla wszelkich rodzajów, klas i szerokości metodą wulkanizacji na zimno lub na gorąco, stosując własny sprzęt i materiały wulkanizacyjne. Do łączenia na gorąco używa się nowoczesnych hydraulicznych pras wulkanizacyjnych, które umożliwiają łączenie taśm o szerokości od 650 do 2250 mm. Świadczone usługi, jak wykazuje praktyka, są szczególnie przydatne w inwestycjach (pierwsze łączenia), przy modernizacjach, wymianach taśm na przenośnikach, a także w sytuacjach awaryjnych.

Zastosowanie specjalnych okładzin gumowych zapobiega przylepianiu się urobku na bębnach, co zwiększa trwałość taśmy, a w przypadku bębnów napędowych skutecznie poprawia sprzężenie ciernie i zapobiega poślizgom. Nakładanie wykonuje się metodą wulkanizacji na zimno dla bębnów o średnicy do 1200 mm.

Ostatnio opracowano nową technologię nakładania okładzin na bębny przenośnikowe i krążniki metodą wulkanizacji na gorąco. Jest to technologia czysta ekologicznie ponieważ pozwala na całkowite wyeliminowanie toksycznych rozpuszczalników i klejów. Ponadto znacznie upraszcza proces technologiczny. W sprawach związanych z przedstawionym tu zakresem działalności można się zwracać do Zakładu Technologii i Eksploatacji Taśm Przenośnikowych w Poltegorze-Instytucie.

#### REFERENCJE

O atrakcyjności naszych usług świadczy różnorodność klientów dotychczas z nich korzystających m.in:

- kopalnie węgla brunatnego (Bełchatów, Konin),

- kopalnie miedzi (Rudna),
- kopalnie węgla kamiennego (Siersza, Zofiówka),
- kopalnie rud ołowiu i cynku (Trzebionka),
- Kombinat Metalurgiczny Huta Katowice,
- liczne cukrownie, elektrociepłownie (Wrocław, Poznań),
- w Czechach:
- port rzeczny nad Łabą (Lovosice),
- w Rumunii:
- fabryka płyt wiórowych (Braila),
- w Niemczech:
- kopalnie soli potasowych (Glückauf, T. Müntzer),
- elektrownie (Thierbach),
- kopalnie węgla brunatnego (Witniz, Welzow),
- z Węgier:
- zakłady wapiennicze (Berement),
- z Maroka:
- fabryka kwasu siarkowego (Safi),
- z Turcji:
- elektrownie (Yatagan, Kömerkoj).

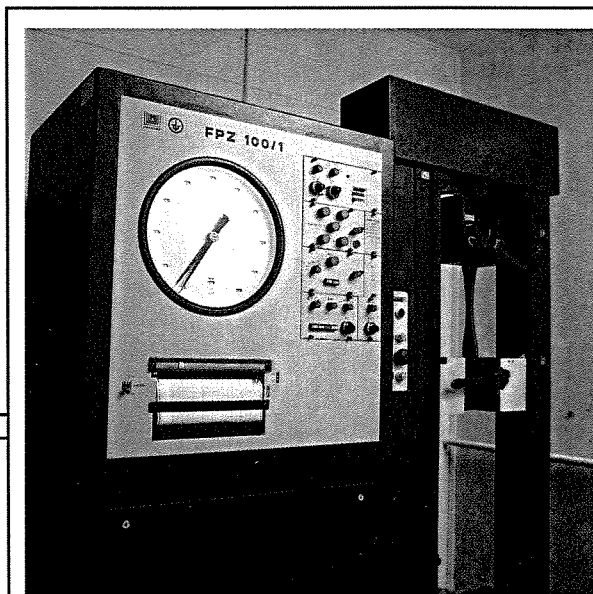

Application of special rubber linings prevents accumulation of the excavated material on the drums, due to which belt life is increased and in the case of driving drums frictional contact is significantly improved and it prevents sliding. Applying is performed by cold vulcanization for the drums of the diameter up to 1200 mm.

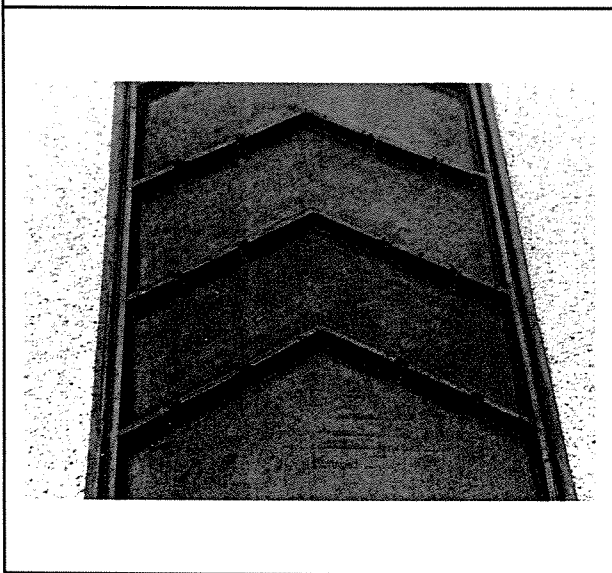

Lately a new technology of applying linings on conveyor drums and idlers with hot vulcanization has been worked out. It is an ecologically "clean" technology since it makes it possible to eliminate completely toxic dissolvents and glues. Besides it considerably simplifies technological process.

In order to get more detailed information concerning the presented range of activities refer to Department of Technology and Exploitation of Conveyor Belts - Poltegor-Institute.

#### REFERENCES

A great diversity of our customers speaks for the attractiveness of our offer. We have rendered our services, among others, to:

- brown coal mines: (Bełchatów, Konin),
- copper mine (Rudna),
- bituminous coal mines (Siersza, Zofiówka),
- lead and zinc ore mine (Trzebionka),
- Metallurgical Industrial Complex, Katowice Steel Mill,
- numerous sugar factories,
- heat and power generating plants (Wrocław, Poznań),
- in the Czech:
- river port on Elbe (Lovosice),
- in Romania:
- chipboard factory (Braila),
- in Germany:
- potassium salts mine (Glückauf, T. Müntzer),
- power plants (Thierbach),
- brown coal mines (Witniz, Welzow),
- in Hungary:
- limestone plants (Berement),
- in Morocco:
- sulphuric acid plant (Safi),
- in Turkey:
- power plants (Yatagan, Kömerkoj).



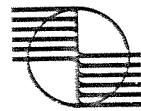

poltegor - instytut

DOŚWIADCZALNA KOREKTA  
STATECZNOŚCI NADWOZI MASZYN

EXPERIMENTAL CORRECTION OF  
MACHINE SUPERSTRUCTURE STABILITY

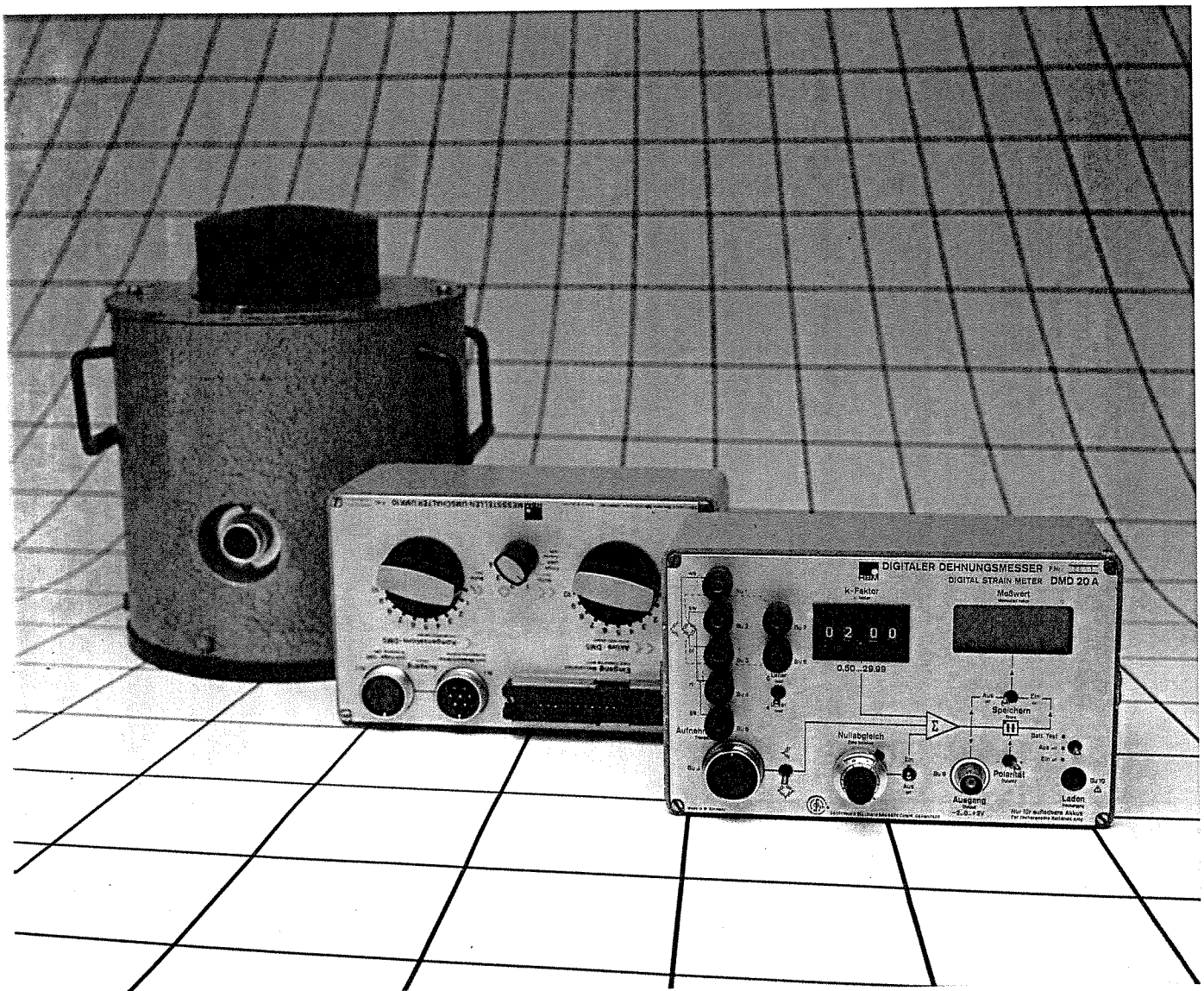

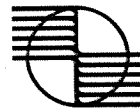

**poltegor - instytut**

---

**NOWA GENERACJA WYSOKOWYDAJNYCH  
DRENÓW DO ODWADNIANIA I NAWADNIANIA**

**NEW GENERATION OF HIGH-EFFICIENCY DRAIN  
PIPES FOR DRAINAGE AND IRRIGATION**

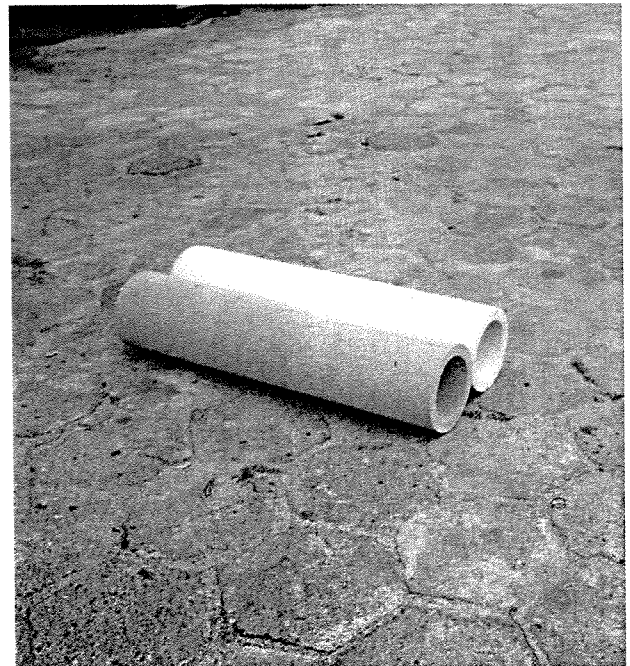

**NOWA GENERACJA WYSOKOWYDAJNYCH  
DRENÓW DO ODWADNIANIA  
I NAWADNIANIA**

W nowej konstrukcji elementem filtrującym jest specjalna przepuszczalna okładzina ze struktury porowatej. Szkielet może być dowolnego kształtu o dużych otworach perforacji.

Elementy filtracyjne (w odcinkach np. jednometrowych) nakładane na perforowany szkielet umożliwiają właściwy dobór struktury porowatej w zależności od granulacji warstwy filtrowej.

**WARUNKI FILTRACJI**

Dotychczas dreny posiadały otwory bardzo rzadko rozmieszczone (mały współczynnik perforacji), a ich średnica musiała być mniejsza od ziaren filtrowanego materiału. Obecnie w Poltegorze-Instytucie opracowano specjalne okładziny filtracyjne o strukturze porowatej, posiadające bardzo dobrą przepuszczalność dzięki dużej ilości gładkich kanalików. Szkielet może posiadać otwory o większych średnicach (współczynnik perforacji powyżej 10%) - nie ulega więc szybko kolmatacji, a nałożona okładzina filtracyjna zapewnia dużą sprawność filtracji.

Przeprowadzone badania laboratoryjne i terenowe pozwalają na stwierdzenie, że *nowa generacja wysokowydajnych drenów* posiada sprawność około dziesięć razy większą od dotychczas stosowanych.

**PARAMETRY HYDRAULICZNE**

W wyniku przeprowadzonych badań przepływu dla różnych okładzin filtracyjnych ze struktur porowatych określono następujące wydajności:

Rodzaj okładziny	Średnice ziaren D [m]	Wydajność z 1 m <sup>2</sup> powierzchni okładziny Q [m <sup>3</sup> /s]
Żwirowa	$(0,8 \div 1,2) \cdot 10^{-3}$	$0,6 \cdot 10^{-3}$
	$(1,2 \div 2,0) \cdot 10^{-3}$	$1,6 \cdot 10^{-3}$
	$(2,0 \div 3,0) \cdot 10^{-3}$	$3,3 \cdot 10^{-3}$
	$(3,0 \div 5,0) \cdot 10^{-3}$	$4,1 \cdot 10^{-3}$
	$(5,0 \div 7,0) \cdot 10^{-3}$	$7,5 \cdot 10^{-3}$
	$(7,0 \div 10,0) \cdot 10^{-3}$	$10,8 \cdot 10^{-3}$
Tworzywo sztuczne	$(3,0 \div 5,0) \cdot 10^{-3}$	$11,6 \cdot 10^{-3}$

**PROGRAM PRODUKCJI**

Poltegor-Institut produkuje *nowe generacje wysokowydajnych drenów* do odwadniania i nawadniania stosując rury PCW o średnicach  $(110, 160, 225, 280, 315) \cdot 10^{-3}$  m. Oferujemy również wykonawstwo okładzin filtracyjnych o różnych kształtach w zależności od zastosowanych szkieletów.

Materiały użyte do produkcji filtrów posiadają atesty PZH pozwalające na stosowanie drenów do ujmowania również wód pitnych.

**NEW GENERATION OF HIGH-EFFICIENCY  
DRAIN PIPES FOR DRAINAGE  
AND IRRIGATION**

In the new construction the filtrating element is in the form of a special lining of porous structure. The framework can be of any shape with big perforation holes.

Filtrating elements (e.g. one-metre long) put on the perforated framework enable a correct selection of the porous structure depending on filter layer granulation.

**FILTRATION CONDITIONS**

So far drain pipes has had holes which have been very thinly distributed (small perforation coefficient) and their diameter had to be smaller than the grain of the filtered material. Recently Poltegor-Institute has worked out special filtration linings of porous structure characterized with high permeability due to a great number of smooth ducts.. The framework can possess holes of bigger diameters (perforation factor of more than 10%) it does not undergo quick silting-up and the applied filtration lining ensures high filtration efficiency.

Conducted laboratory and field examinations make it possible to claim that *new generation of high efficiency drain pipes* has the efficiency 10 times higher than the one of the drain pipes used so far.

**HYDRAULIC PARAMETERS**

As a result of the conducted examinations on the flow for different filtration linings of porous structures the following efficiencies has been determined:

Type of lining	Grain diameters D [m]	Efficiency from 1 m <sup>2</sup> of area Q [m <sup>3</sup> /s]
Gravel	$(0,8 \div 1,2) \cdot 10^{-3}$	$0,6 \cdot 10^{-3}$
	$(1,2 \div 2,0) \cdot 10^{-3}$	$1,6 \cdot 10^{-3}$
	$(2,0 \div 3,0) \cdot 10^{-3}$	$3,3 \cdot 10^{-3}$
	$(3,0 \div 5,0) \cdot 10^{-3}$	$4,1 \cdot 10^{-3}$
	$(5,0 \div 7,0) \cdot 10^{-3}$	$7,5 \cdot 10^{-3}$
	$(7,0 \div 10,0) \cdot 10^{-3}$	$10,8 \cdot 10^{-3}$
Plastics	$(3,0 \div 5,0) \cdot 10^{-3}$	$11,6 \cdot 10^{-3}$

**PRODUCTION PROGRAMME**

At present Poltegor-Institute produces *new generations of high efficiency drain pipes* for drainage and irrigation making use of PVC pipes of the diameters  $(110, 160, 225, 280, 315) \cdot 10^{-3}$  m. We also offer filtration linings of different shapes according to the applied frameworks.

The materials used for the production possess PZH certificate allowing to use drain pipes at drinking water intakes.

**ORDERING METHOD AND INFORMATION**

POLTEGOR - INSTYTUT, ul. Parkowa 25,  
51-616 Wrocław, phone no. 48-42-81 extension 62-52.

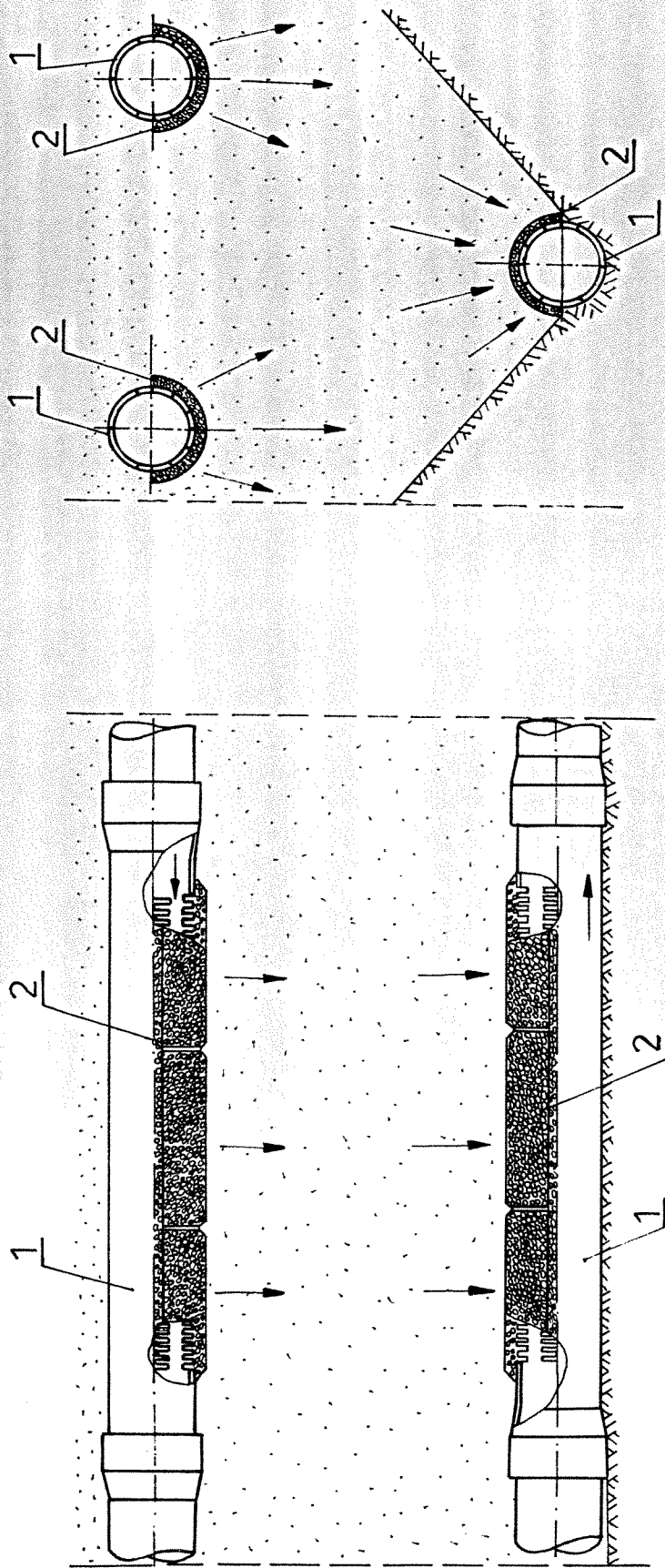

Schemat budowy wysokodajnych drenów produkcji Poltegor-Instytut - Structure of high efficiency drain pipes manufactured by Poltegor-Institute

1. szkielec rurowy - pipe framework

2. okładzina ze struktury porowatej - lining of porous structure

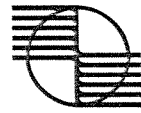

**poltegor - instytut**

---

**PRZEJEZDNE ZWIJADŁO DO TAŚM Typ SPTT2 - z3**

**MOBILE BELT REELING MACHINE Type SPTT2 - z3**



**PRZEJEZDNE ZWIJADŁO DO TAŚM Typ SPTT2 - z3**  
**MOBILE BELT REELING MACHINE TYPE SPTT2 -z3**

**PRZEZNACZENIE**

Urządzenie przeznaczone jest do zwijania taśmy przenośnikowej w zwoje bezpośrednio z przenośnika lub z ziemi, przewożenie jej na drogach utwardzonych i w terenie oraz do rozwijania taśmy na przenośnik. Posiada własny hydrauliczny napęd zwijania taśmy i wyposażone jest w zespoły wstępnego czyszczenia taśmy, korekcji biegu taśmy oraz podpory hydrauliczne. Urządzenie wykonywane jest w dwóch wersjach, zasilane elektrycznie lub wyposażone w silnik spalinowy.

**INTENDED USE**

The machine is used to reel conveyor belt in coils directly from the conveyor or ground, to carry it on hard- and soil-surfaced roads and also, to unreel it to be laid on the conveyor. It has its own belt reeling hydraulic drive and is equipped with preliminary belt cleaning units, belt movement adjusting devices and hydraulic supports. The machine is manufactured in two makes, electrically supplied or provided with I.C. engine.

**DANE TECHNICZNE**  
**TECHNICAL DATA**

		SPTT2- z3/2,25	SPTT2- z3/2,0	SPTT2- z3/1,8	SPTT2- z3/1,6	
Maks. szerokość taśmy Belt width, max	mm	2 250	2 000	1 800	1 600	
Maks. średnica zwoju Coil dia, max	mm	3 000				
Moment na wale Torque at shaft	kNm	70				
Obroty zwijadła Revolutions of reeling machine	obr/min r.p.m.	0 - 5				
Moc napędu Drive power	kW	37				
Zasilanie Supply voltage	V	380 lub (or) 500				
Hamulce Brakes		tarczowe (disk type)				
Prędkość jazdy dopuszczalna Allowable travelling speed	- pod obciążeniem - under load	km/h	10	10	15	20
	- bez obciążenia - under no load	km/h	20	20	20	20
Masa Weight	kg	18 900	18 670	18 450	18 220	
Moc ciągnika holującego Power of haulage tractor	kW	250	200	180	150	

**PRZEDSIĘBIORSTWO PROJEKTOWO - WDROŻENIOWE**

**POLMAGOR** Sp. z o.o.

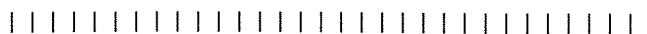
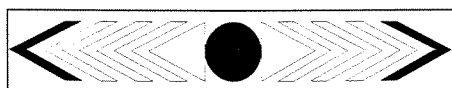

**56-616 Wrocław, ul. Parkowa 25**

**tel. (071) 48-42-81**

Licencja, IGO "POLTEGOR - INSTYTUT"

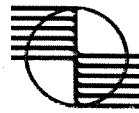

**poltegor - instytut**

---

STANOWISKO DO BADAŃ KOMPLEKSOWYCH MASZYN  
I URZĄDZEŃ W GÓRNICTWIE ODKRYWKOWYM

STAND FOR INTEGRATED TESTS OF SURFACE MINING  
MACHINERY AND EQUIPMENT

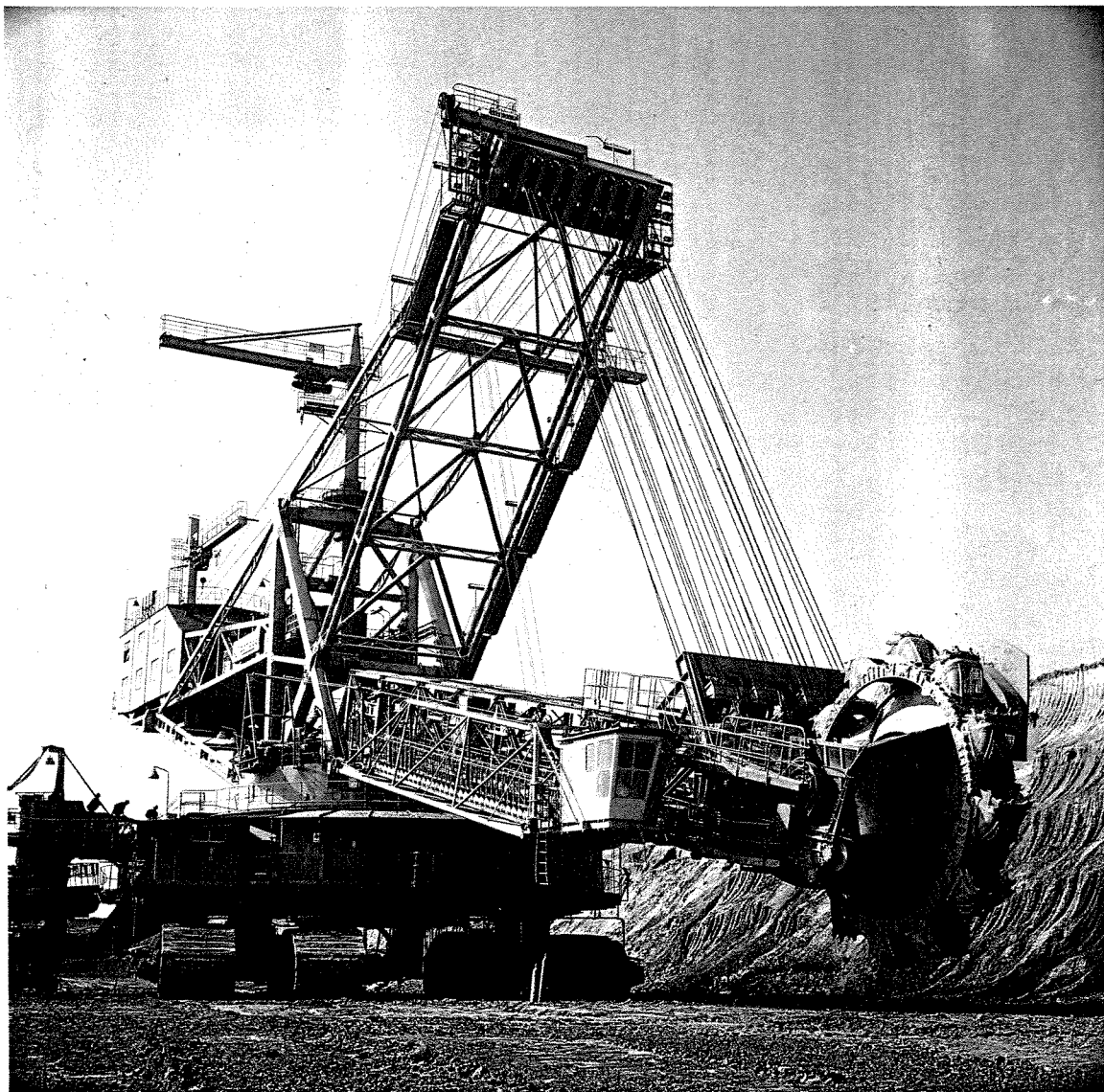



STANOWISKO DO BADAŃ KOMPLEKSOWYCH MASZYN I URZĄDZEŃ  
W GÓRNICTWIE ODKRYWKOWYM  
STAND FOR INTEGRATED TESTS OF SURFACE MINING MACHINERY AND EQUIPMENT

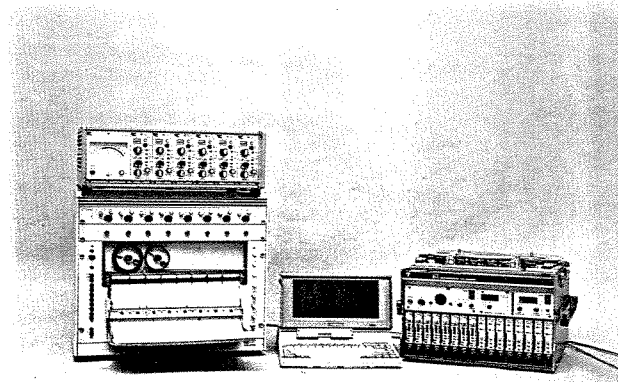
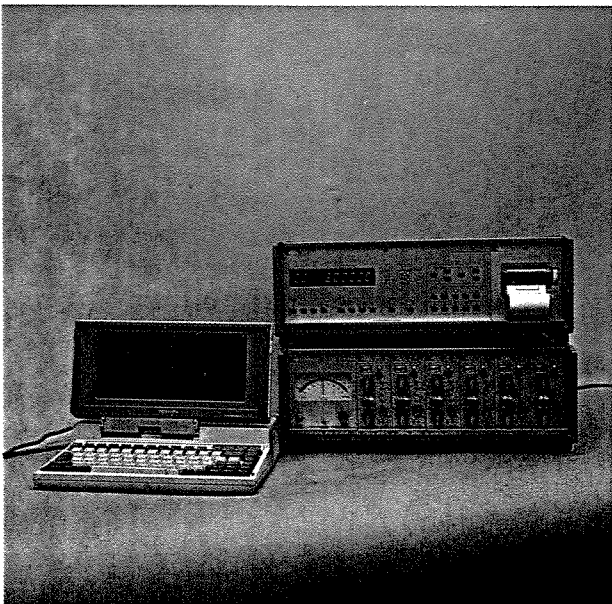
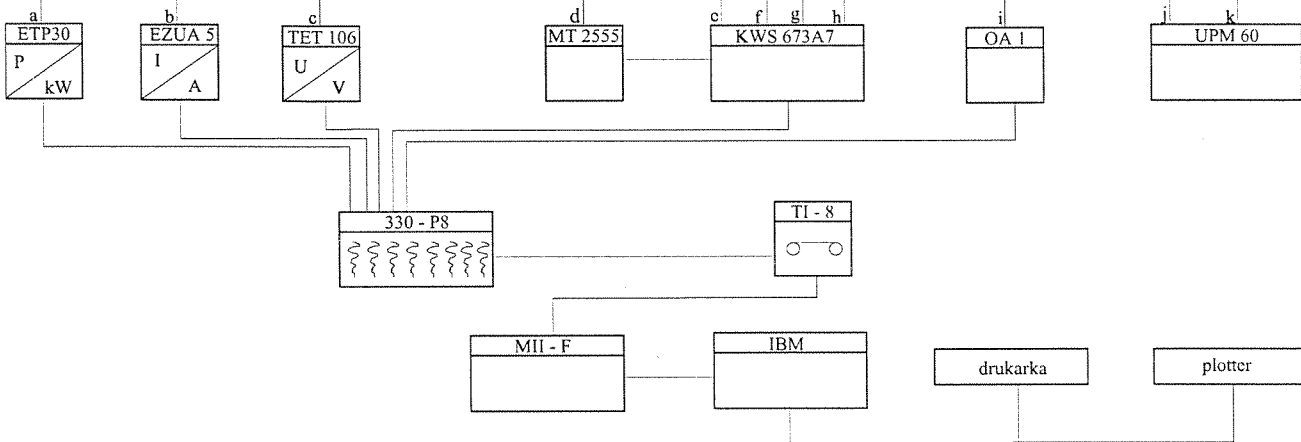
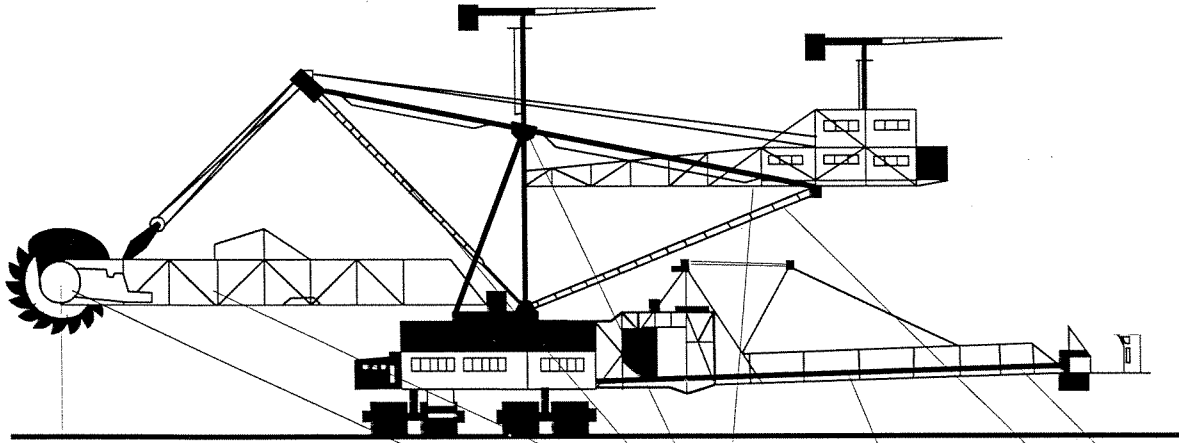

ORDERING METHOD AND INFORMATION  
POLTEGOR - INSTYTUT, ul. Parkowa 25,  
51-616 Wrocław, phone no. 48-42-81.





ZESTAWIENIE STOSOWANEJ APARATURY DO BADAŃ KOMPLEKSOWYCH MASZYN

Pomiar		Stosowana aparatura					
Oznaczenie na rysunku	Nazwa	Typ	Nazwa	Firma	Typ	Nazwa	Firma
a, b, c	wartości elektrycznych silnika napędu koła czepakowego	ETP 30 EZUA 5 TET 106	przełącznik mocy przetwornik prądu przetwornik prądu	Hartman - Braun	330-P8 TI-8 MII-F	rejestrator szybkopiszący rejestrator magnetyczny system pomiarowo-rejestr.	Hellige Transinstrument B+S Software u. Messtechnik Hawlet Packard
d	momentu na wale koła czepakowego	MT 2555 EV 2510 MD 2555	telemetryczny system pomiarowy	Hottinger Baldwin	IBM	drukarka ploter	
e, f, g, h	naprężeń w konstrukcji	KWS 673A7	wzmacniacz pomiarowy	Mess- technik			
i	prędkości taśm	OA-1	czujnik optyczny				
j, k	naprężeń w konstrukcji z wydrukiem wyników	UPM 60	wielopunktowe urządzenie pomiarowe				

SPECIFICATION OF DEVICES USED FOR INTEGRATED TESTS OF MACHINERY

Measurement		Devices in Use					
Symbols in Drg.	Description	Type	Description	Mfgd.	Type	Description	Mfgd.
a, b, c	Electrical ratings of bucket wheel drive motor	ETP 30 EZUA 5 TET 106	Power relay Current transducer Current transducer	Hartman - Braun	330-P8 TI-8 MII-F	Quick-recording device Magnetic recorder Measuring-recording system	Hellige Transinstrument B+S Software u. Messtechnik Hawlet Packard
d	Torque at bucket wheel shaft	MT 2555 EV 2510 MD 2555	Remote measuring system	Hottinger Baldwin	IBM	Printer Plotter	
e, f, g, h	Structural stresses	KWS 673A7	Measuring amplifier	Mess- technik			
i	Belt speed	OA-1	Optimeter				
j, k	Structural stresses with printout	UPM 60	Multi-point measuring devices				

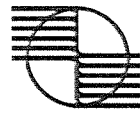

poltegor - instytut

---

## PRACOWNIA ENERGETYKI GÓRNICZEJ HEAVY CURRENT ENGINEERING IN MINES



**PROFIL DZIAŁALNOŚCI**

1. Wdrażanie nowych rozwiązań z zakresu energooszczędnej pracy układów energoelektrycznych dla górnictwa odkrywkowego, kopalń dołowych oraz innych branż przemysłu.

Przykładowe rozwiązania:

- układ energooszczędnej pracy przęnośników taśmowych powierzchniowych,
- układ energooszczędnej pracy przęnośników taśmowych dołowych,
- układ energooszczędnej pracy pomp głębinowych i powierzchniowych,
- układ energooszczędnej pracy wentylatorów przemysłowych,
- układy rozruchowe silników indukcyjnych pierścieniowych i klatkowych,
- wyrównywanie obciążeń w napędach wielosilnikowych z silnikami klatkowymi i pierścieniowymi,
- napędy regulowane prądu stałego i przęmiennego,

- zabezpieczenia przęteżeniowe i ziemnozwarciowe silników prądu stałego i przęmiennego.

2. Produkcja urządzeń pomiarowych dla potrzeb górnictwa odkrywkowego.

Przykładowe rozwiązania:

- układ pomiaru i kontroli kąta pochylenia UKP - 3 i UKP - 3/N,
- inklinomierz I - 01.

3. Produkcja urządzeń energoelektrycznych dla potrzeb przemysłu.

Przykładowe rozwiązania:

- rozrusznik wiroprądowy segmentowy Zcdb do silników pierścieniowych o mocy: 320 kW , 630 kW , 1000 kW.
- rozrusznik wiroprądowy rurowy do silników pierścieniowych o mocach od 7,5 do 200 kW.

4. Projektowanie i wykonawstwo napędów regulowanych dla potrzeb przę-

mysłu.

Przykładowe rozwiązania:

- kaskada asynchroniczna do skokowej regulacji prędkości przęnośników taśmowych z silnikami indukcyjnymi pierścieniowymi,
- kaskada na stałą moc do ciągłej regulacji prędkości prasy walcowej do brykietowania węgla.

5. Pomiary elektroenergetyczne w obiektach przemysłowych.

Przykładowe rozwiązania:

- układ kontroli energochłonności dla celów dyspozytorskich KWB Turów - projekt i zabudowa układu,
- pomiary charakterystyk silników oraz maszyn roboczych, takich jak przęnośniki, pompy, wentylatory, sprężarki, prasy itp. w kopalniach węgla brunatnego oraz w innych branżach przemysłu.

**HEAVY CURRENT ENGINEERING IN MINES  
RANGE OF ACTIVITIES**

1. Implementation of new techniques for energy-saving operation of power supply systems in surface mines, underground mines and other industries.

Exemplary applications:

- energy-saving operating systems of belt conveyors in surface mines,
- energy-saving operating systems of belt conveyors in underground mines,
- energy-saving operating systems of submersible and minehead pumps,
- energy-saving operating systems of industrial fans,
- starting systems of slip-ring and squirrel-cage induction motors,
- compensation of loads in multi-motor drives with squirrel-cage and slip-ring motors,
- D.C. and A.C. adjustable drives,
- over-current and ground-fault protections for D.C. and A.C. motors.

2. Manufacture of measuring devices to be used in surface mines.

Exemplary applications:

- heel angle measuring and control system UKP - 3 and UKP - 3/N,
- inclinometer I - 01.

3. Manufacture of power supply equipment to be employed in the industry.

Exemplary applications:

- segmented eddy current starter Zcdb for slip-ring motors 320 kW, 630 kW, 1000 kW,
- tubular eddy current starter for slip-ring motors rated from 7,5 to 200 kW.

4. Designing and workmanship of adjustable drives to be employed in the industry.

Exemplary applications:

- asynchronous cascade for stepping speed control of conveyor belts driven by slip-ring induction motors,
- constant-power cascade for infinitely variable adjustment of roll press used for coal briquetting.

5. Heavy current measurements within industrial facilities.

Exemplary applications:

- energy-consuming rate control system to be employed in the control room of Turów Lignite Open Pit - design and installation,
- performance measurements of motors and working machinery such as conveyors, pumps, fans, compressors, presses, etc. to be made in surface mines of lignite and other industries.

## **Appendix 4: Information about NIVA**

# Research and Development

The Norwegian Institute for Water Research (NIVA) has been Norway's leading centre of hydrological expertise since 1958. NIVA carries out research, surveys and development work on contract for public authorities and private clients in Norway and abroad. NIVA helps to build up competence in hydrology and disseminate information to scientists, politicians and the public. NIVA has a staff of 190, of whom 80 are research scientists. These include specialists in chemistry, biology, limnology, environmental technology, environmental toxicology, veterinary medicine, oceanography, geography and economics. With this wide range of expertise, NIVA has the best possible qualifications to design multi-disciplinary strategies for research and development projects which, together with political decisions, can help to solve current problems relating to all aspects of water and its uses.

NIVA's research and development activities cover the following fields; precipitation, groundwater, lakes, rivers, fjords and coastal and open ocean waters. The Institute monitors and analyzes water quality and pollution in connection with:

- \* industry
- \* agriculture
- \* municipal discharges
- \* transport
- \* oil and gas production
- \* hydropower development
- \* aquaculture

An important part of NIVA's research consists of studying how nutrients, micropollutants, acid precipitation and changes in climate affect water quality and aquatic ecosystems.

In order to shed light on today's complex environmental problems, NIVA employs methods and techniques such as:

- \* chemical and biological analyses
- \* remote sensing
- \* ecological test methods
- \* model calculations

NIVA does research on environmental technology connected to cleaning of water, industrial processes and biotechnology, with a view to finding practical solutions to environmental problems in water. Other important tasks include developing better methods for integrated planning of water resources and preparing plans of action to improve the environment.

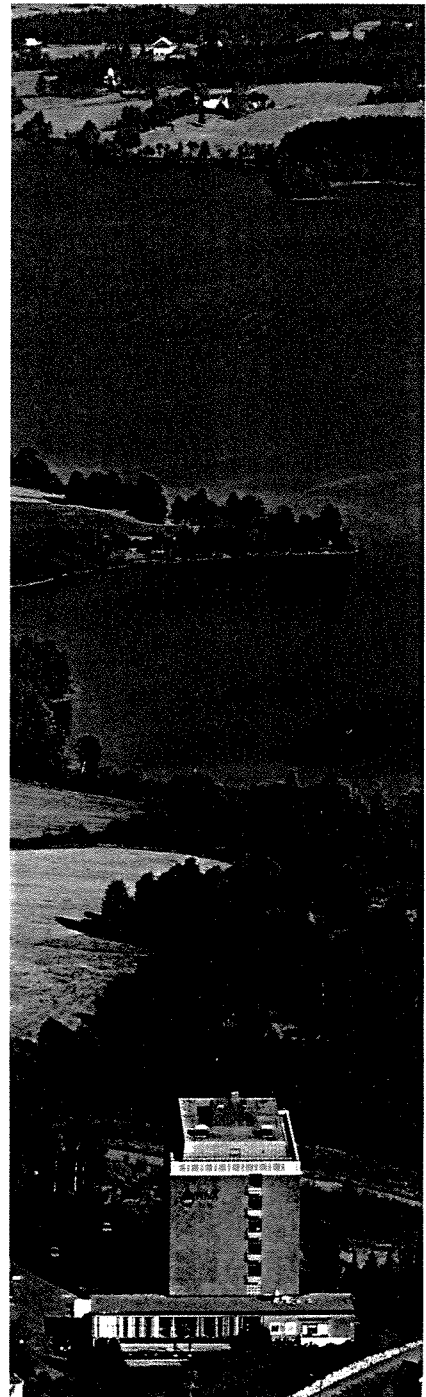
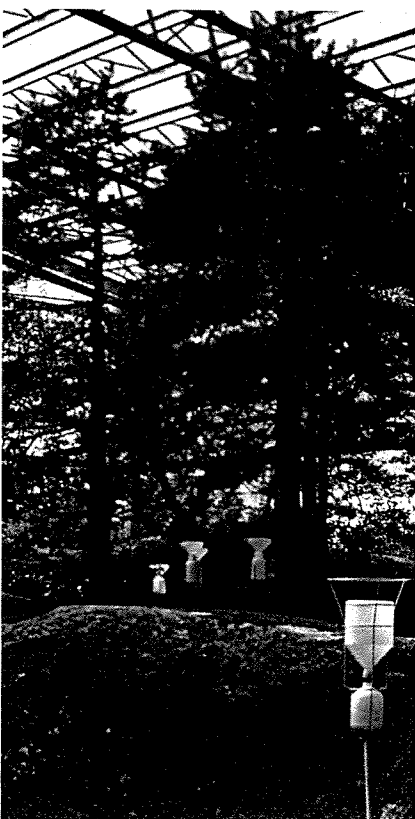

# Research Facilities

## **Analytical laboratory**

NIVA's analytical laboratory carries out a wide variety of chemical analyses with a high degree of automation of sample processing and handling of information. The laboratory uses advanced analytical instruments, including Inductive Coupled Plasma Emission Spectrometer (ICP), Graphite Furnace Atomic Absorption Spectrophotometers, Gas Chromatographs and a Gas Chromatograph/Mass Spectrometer (GC/MS). Special emphasis is placed on analytical methods with high specificity and low detection limits. The laboratory is in the process of introducing a system of quality assurance conforming to the EN 45 000-standard.

## **Ecotoxicological test laboratory**

NIVA's ecotoxicological test laboratory offers more than 30 biological tests to determine toxicity, degradation and bioaccumulation of pollutants in marine and freshwater environments. The tests are performed in laboratories with climate control and direct supply of water of high and stable water quality from a nearby lake. These conditions provide the very best opportunities for testing the longterm effects of chemicals and waste water on selected aquatic organisms and communities.

## **Marine Research Station Solbergstrand**

NIVA's marine research station at Solbergstrand offers facilities for research on basic marine biology, pollution and aquaculture. Experiments are carried out in model ecosystems where natural variables such as currents, waves, light, temperature and water quality are

retained or simulated. The model ecosystems are used for environmental impact studies, tests on the mobilization and bioavailability of micropollutants in contaminated sediments, and investigations on degradation of organic pollutants in marine environments.

## **Freshwater model ecosystems**

NIVA operates various units for freshwater model ecosystem experiments. The enclosure unit is a mobile installation placed directly in a natural freshwater ecosystem. Model ecosystems (limnocorrals) are produced by isolating segments of the local ecosystem in temporary enclosures. The experimental stream unit is a permanent installation used to simulate ecosystems in running water.

## **NIVA's Culture Collection of Algae**

The main purpose of NIVA's culture collection of algae is to supply algae for use in research, education and industry. Most of the algae originate from Norwegian lakes, rivers and coastal waters. The clone cultures in the collection number about 400, and represent 160 species. The collection specializes in cultures of cyanophytes. NIVA's collection of algae is registered as No. 498 in the World Directory of Collections of Cultures of Microorganisms (WFCC) and is entered in the European Culture Collections Organization (ECCO).

## **Risdalsheia - CLIMEX**

At the Risdalsheia Research Station, well known from the RAIN project, two entire forested headwater catchments have been enclosed by large transparent walls and roofs

to form large-scale model ecosystems. The units will be used to investigate the ecological effects of expected climatic and atmospheric changes caused by emissions of greenhouse gases. The research project, CLIMEX, offers a unique opportunity to study the interaction between plants, soil and water under altered climatic and atmospheric conditions.

## **Mobile laboratories**

MOBILLAB-NIVA is a complete mobile unit for monitoring water quality with telemetric transmission of recorded data to a central receiving station. The unit is equipped with physical and chemical sensors for continuous measurement of chemical and physical conditions in different locations, and also contains experimental tanks and reference tanks for fish and invertebrates.

## **Bekkelaget pilot plant**

At NIVA's pilot plant at Bekkelaget, experiments are being carried out on biological removal of nitrogen from waste water. The method being tested is based on a high degree of automatic monitoring and process control. The objective is to achieve the best possible cost efficiency for treatment of waste water.

---

## **Norwegian Institute for Water Research**

P.O.Box 173 Kjelsås  
N-0411 Oslo Norway

Phone: +47 22 18 51 00  
Fax: +47 22 18 52 00

---

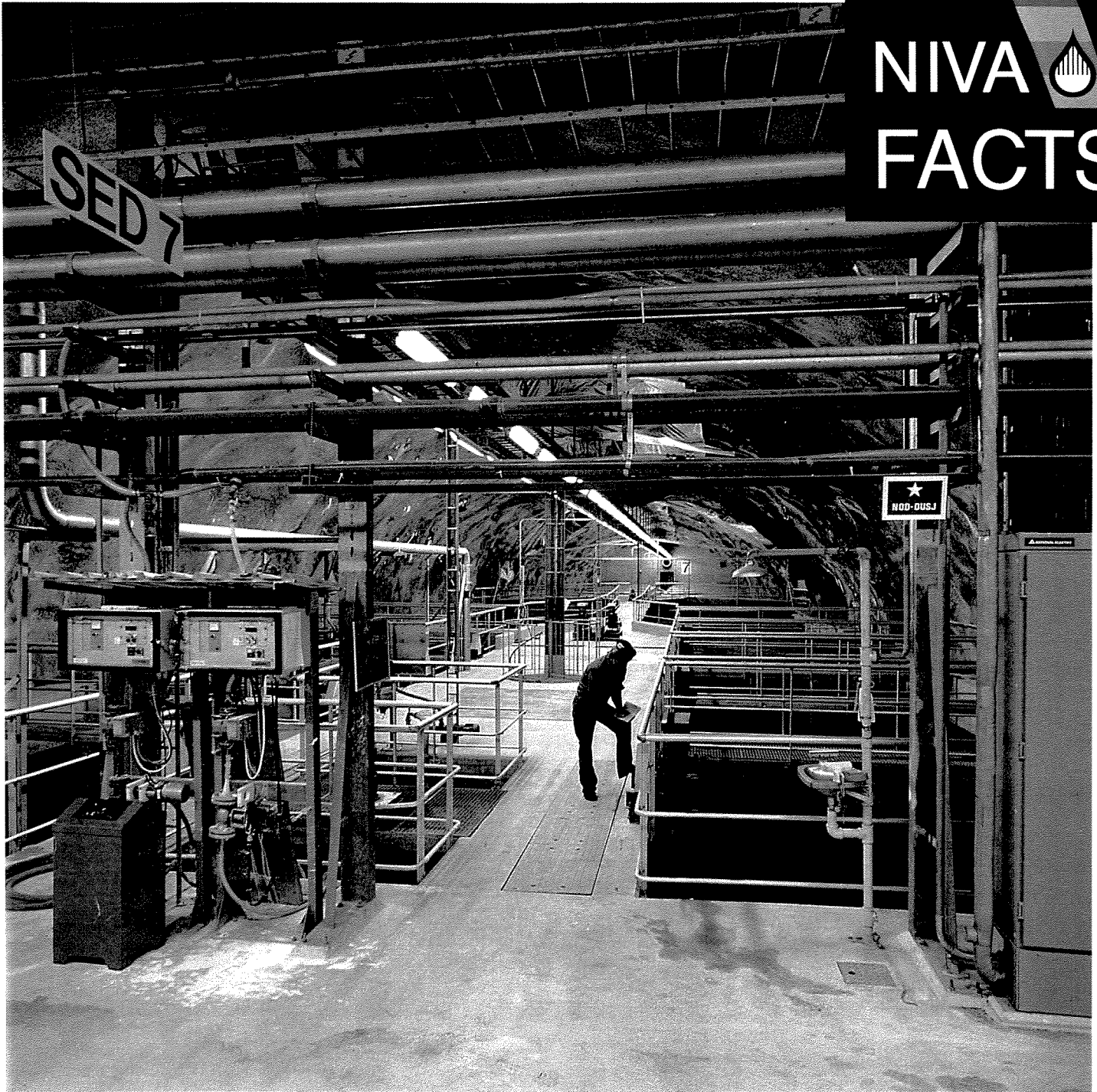

Photo: I. Davies, Oslo Energi

# Environmental technology

Research manager: *Gunnar Fr. Aasgaard*

Today's and tomorrow's environmental problems are best solved through effective integration of natural science and technology.

This has been NIVA's basic philosophy since the institute was established in 1958. As the environmental problems increase in complexity, multidisciplinary cooperation becomes more and more

important in the attempts to find effective solutions.

The figure shows some of the elements in a multidisciplinary solution to environmental problems.

**Basic knowledge**

- \* Biology
- \* Chemistry
- \* Physics/mechanics
- \* Mathematics/statistics

**Solutions based on environmental technology**

**Knowledge of systems**

- \* Treatment processes
- \* Transport systems
- \* Interaction/optimization

**Access to technical aids**

- \* Sensors/instruments
- \* Laboratory services
- \* IT-tools

# Services and Research

The Norwegian Institute for Water Research offers:

- advanced expertise on chemical treatment of municipal and industrial wastewater
- identification and testing of suitable chemicals
- evaluation and optimization of chemical treatment (coagulation, flocculation and sedimentation)
- systems for automatic control of dosing equipment in water supply installations and wastewater treatment plants, based on online measurement of physical/chemical parameters
- professional assistance in planning, operation and optimization of water supply plants
- development and adaption of methods for biological removal of nutrients from wastewater
- models for process selection and system optimization at municipal water supply installations and wastewater treatment plants
- analyses of transport systems and treatment plants to ensure the best possible solution from both the economic and environmental point of view
- survey of areas polluted by mining operations and proposal of methods to reduce pollution
- advanced expertise on removal of heavy metals from industrial wastewater
- chromium and cyanide detoxification
- systems for surveillance of rivers and streams of wastewater

## Bekkelaget pilot plant

The North Sea countries have agreed on a 50% reduction of the phosphorus and nitrogen discharges. To fulfill this obligation and also to prevent local pollution effects, Norway is increasing its nitrogen treatment capacity.

NIVA is performing a test programme for biological nitrogen removal at Norway's second largest treatment plant, Bekkelaget in Oslo. The chosen process, predenitrification in activated sludge, is well known

from other countries, but has not been used in Norway before. At Bekkelaget the process is being tested under Norwegian conditions, i.e. low temperatures and diluted wastewater.

The Norwegian tradition of covering treatment facilities has resulted in a focus on high-rate processes with modest space requirements. In many cases these processes have high operational costs. The objective of the study at Bekkelaget is to determine if the stable, low cost operation of the activated sludge process makes it a cost-efficient alternative in spite of the increased volume it entails.

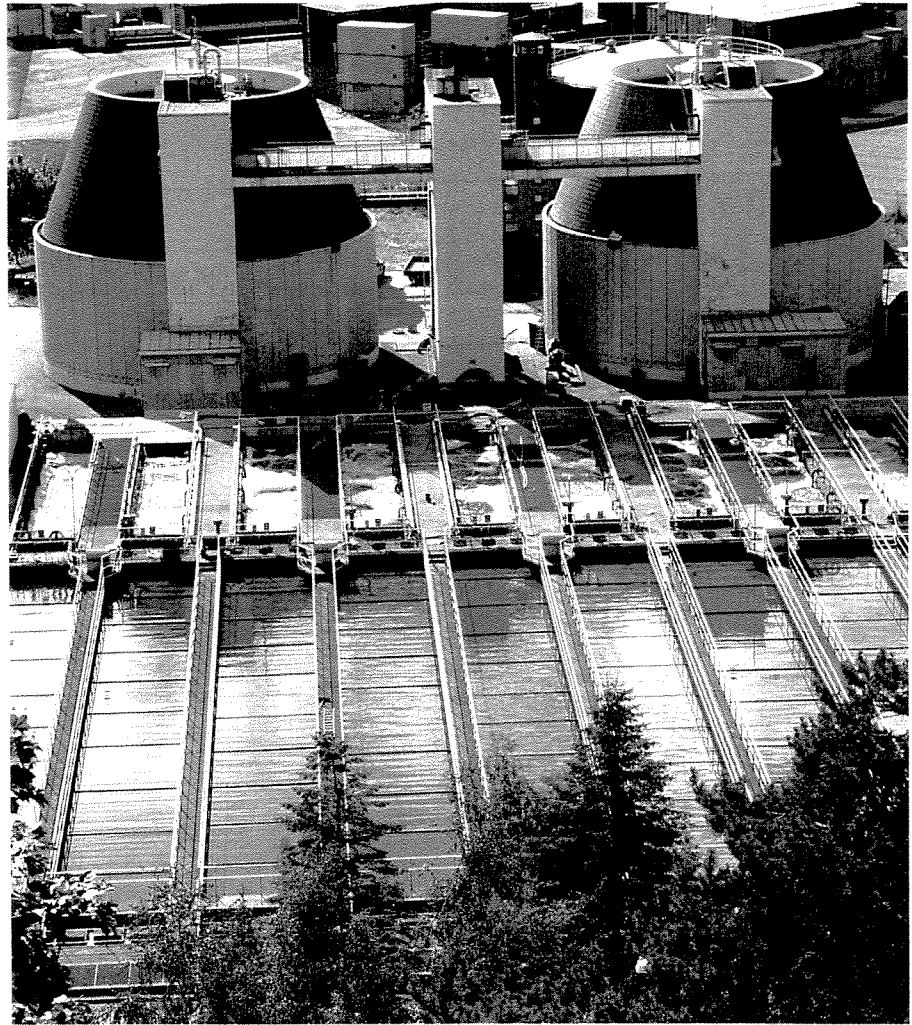

Photo: Haugen & Maning



Norwegian Institute  
for Water Research

P.O.Box 69 Korsvoll  
N- 0808 Oslo, Norway  
Phone: + 47 22 18 51 00  
Fax: + 47 22 18 52 00





# Upgrading of Existing Wastewater Treatment Plant Facilities in Poland, Hungary and the Czech Republic

Project manager:  
*Svein Stene-Johansen*

The projects are conducted by the Norwegian Institute for Water Research (NIVA), assisted by Aquateam - the Norwegian Water Technology Centre A/S.

Cooperative programme between the Norwegian government and the governments of Poland, Hungary and the Czech Republic.

The projects on upgrading of existing wastewater treatment plant facilities are associated with the Cooperative Programme between the Norwegian government and the governments of Poland, Hungary and the Czech Republic, who are now coming to terms with the serious pollution situation in their countries.

The background of the upgrading projects is a successful Norwegian research and development project called "Operation of treatment plant facilities in Norway." This involved a cost-effective approach to the upgrading of existing wastewater treatment facilities and the introduction of intensive training programmes for plant operators.

Similar, though smaller scale projects, have been initiated in Poland, Hungary and the Czech Republic.

The objectives of the projects are

- to make cost-effective improvements to wastewater treatment efficiency
- to provide information for development of a strategic plan and policy through evaluation of existing treatment facilities and full-scale experiments
- transfer of knowledge.

The costs incurred by the NIVA-team, including operating costs, are met by the Norwegian government, while those of the national coordinators and participants are borne by the respective governments.

## Services:

- Selection of treatment plants
- Identification of problems
- Field investigations
  - Flow measurements and proportional sampling
  - Use of portable computers for data retrieval
  - Bacteriological and chemical analysis
- Verbal report to the plant management and local authority
- Diagnostic study of a number of selected treatment plants
- Report including operation and maintenance performance
- Full scale experiments including evaluation report
- Seminar for wastewater treatment plant operators with presentation of manuals, etc.
- Conference for managers and representatives of local and central authorities with emphasis on wastewater treatment strategy

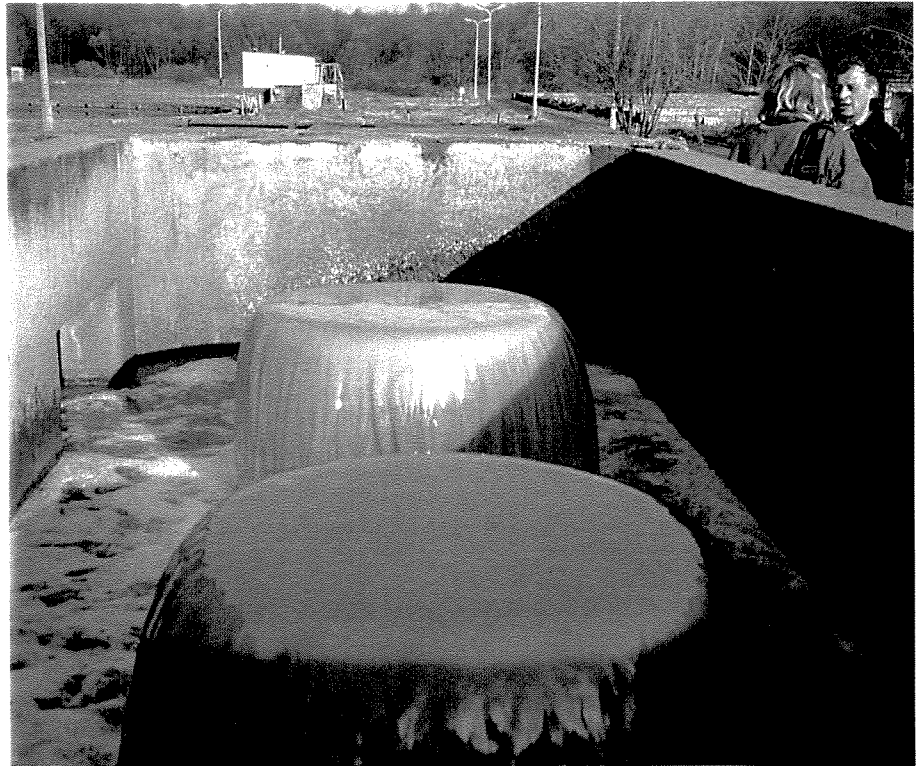

Wastewater treatment plants.



Norwegian Institute  
for Water Research

P.O.Box 69 Korsvoll  
N- 0808 Oslo, Norway  
Phone: + 47 22 18 51 00  
Fax: + 47 22 18 52 00



## Sektor

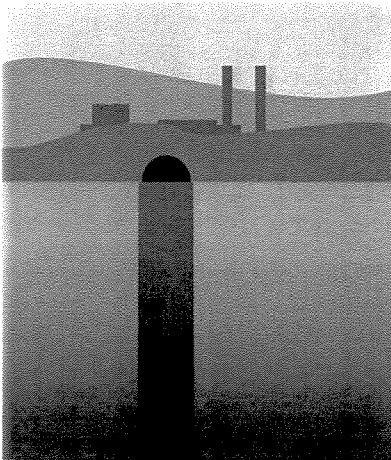

## Miljøteknologi

Vannforsyning  
Avløpsteknologi  
Vannforurensning fra gruver  
Akvakultur  
Algekulturteknologi  
Måle- og overvåkingsteknologi

### Vannforsyning

Det stilles strenge krav til kvaliteten på drikkevann og vann som skal benyttes til produksjon av næringsmidler. Og disse kvalitetskravene skal være oppfylt ved tappestedet. Ved vurdering av tiltak for å forbedre vannkvaliteten er det viktig å se de ulike elementene i vannforsyningen i sammenheng, slik at den optimale totalløsningen kan finnes.

Fra det øyeblikk vannet faller som nedbør til det når fram til en vannkilde blir kvaliteten påvirket av lufttransporterte forurensninger, aktivitet i nedbørfeltet og av lokale, geologiske forhold. Også i selve vannkilden (elv, sjø eller grunnvannsmagasin) kan kvalitetsendringen være betydelig, og kunnskap om dette bør utnyttes slik at etterfølgende behandling kan reduseres til et minimum.

I behandlingsanlegget i vannverket gjennomgår vannet rensprosesser som er tilpasset

råvannskvaliteten og kravene til sluttkvalitet hos konsumentene. Dette måles ved hygieniske og bruksmessige parametre. Spesiell oppmerksomhet må vies forhold som påvirker vannkvaliteten i distribusjonsnett, og som igjen påvirker begroing, korrosjon og utlekking.

NIVA er et flerfaglig forskningsinstitutt som har bred kompetanse og erfaring innen vannforsyning. Instituttets limnologer og biologer vurderer forholdene i nedbørfelt og vannkilder. Målet er å utnytte naturens egne mekanismer til å skape et best mulig utgangspunkt for behandling og distribusjon av

Oset vannrenseanlegg ved Maridalsvannet i Oslo.  
Foto: Oslo vann- og avløpsverk (OVA)



drikkevann. Kjemikere og mikrobiologer karakteriserer vannets egenskaper som grunnlag for valg av prosess tekniske løsninger. Utforming og uttesting av behandlingsprosesser gjennomføres av NIVAs ingeniører, eventuelt i samarbeid med oppdragsgiverens konsulent. Uttesting kan gjøres i vannverket eller ved bruk av instituttets eget pilotanlegg. Også på driftssiden kan NIVAs forskere bistå ved utvikling og implementering av styringssystemer.

NIVA deltar for øvrig i nasjonal og internasjonal forskning. Det kan være knyttet til helsemessige virkninger av naturlig organisk materiale i vann, som humusforbindelser og mikroalger, men kan også gjelde utvikling av nye rensemetoder i samarbeid med industri og forvaltning.

## Avløpsteknologi

Brukt vann renses lokalt eller ledes via avløpsledninger til et avløpsrenseanlegg før utslipp til resipient. Valg av rens metode er avhengig av så vel resipientforhold som sammensetning og variasjon på det urensede avløpsvannet. Resipientforholdene danner utgangspunkt for fastsettelse av utslippskrav. Kvaliteten på det urensede avløpsvannet er avhengig av en rekke forhold på påslippsstedene (for eksempel husholdninger og industri) og i selve avløpsnett (blant annet avløpssystem og ledningskvalitet). Men også drikkevannskvaliteten, spesielt alkaliteten, påvirker prosessene i avløpsrenseanlegget.

En totalanalyse av avløpsforholdene er viktig for å få til en optimal løsning gjennom gode, samordnede tiltak. NIVA har i denne sammenhengen bred kompetanse der kjemikere, biologer, mikrobiologer og ingeniører supplerer hverandre ut fra den aktuelle oppgaven. På teknologiområdet har instituttet spesiell kompetanse innen kjemisk felling, biologisk fosfor- og nitrogenfjerning samt utvikling og imple-

mentering av styringssystemer.

NIVA er engasjert i prosjekter for rensing av så vel kommunalt som industrielt avløpsvann og slam. Instituttet har gode fasiliteter for eksperimentelle forsøk og analysevirksomhet, og kan med sitt mobile forsøksanlegg foreta uttesting av ulike prosessløsninger for et gitt avløpsvann. Ved grundige analyser tidlig i planleggingen vil riktig kombinasjon av enhetsprosesser kunne finnes, med store kostnadsbesparelser som resultat.



Rensing av avløpsvann ved Bekkelaget i Oslo.

Foto: Steinar Haugberg, Samfoto

NIVA deltar også i utvikling av nye rensemetoder, gjennom samarbeid med industri, brukere og forvaltning i nasjonale og internasjonale forskningsprosjekter.

## Vannforurensning fra gruver

En spesiell form for avløpsvann er sigevannet fra de mange metall-

gruvene i Norge. NIVAs arbeid innenfor dette feltet er rettet mot tungmetallholdig avløpsvann fra sulfidmalmgruver. Denne virksomheten kan deles inn i tre hoveddeler:

- undersøkelse av virkninger av gruveavløp i resipienter
- kvantifisering av forurensningstransport fra gruveområder
- tiltak mot vannforurensning fra gruver.

Effektene av gruveavløp er først og fremst avhengig av vannets innhold av tungmetaller. NIVA har lang erfaring med opplegg og gjennomføring av biologiske og kjemiske undersøkelser i gruvepåvirkede vassdrag.

For å kunne gjennomføre effektive tiltak mot forurensning i gruveområder er det nødvendig å kjenne den relative betydningen av de ulike forurensningskildene i området. Det gjelder for eksempel gruvevann, avrenning fra velter og avløp fra avgangsdeponier. I de senere år har NIVA gjennomført en rekke undersøkelser med en slik kartlegging som hovedformål. Undersøkelsene gjennomføres ved omfattende prøvetaking for kjemisk karakterisering kombinert med gode vannføringsmålinger.

Tiltak mot gruveforurensninger er et meget vidt arbeidsfelt. Tradisjonelt har NIVA arbeidet mest med mulighetene som ligger i utnyttelse av lokale naturforhold for motvirkning av forurensning. Her er anvendelse av vann til overdekning av gruver og avgangsdeponier viktige eksempler. Det er blant annet utviklet en matematisk modell for beregning av fremtidig utløsning av forurensninger fra et vanddekket avgangsdeponi. Modellen er benyttet med godt resultat for flere deponier i Norge og Sverige.

De siste årene har NIVA også arbeidet med kjemisk rensing av gruvevann. Basert på flere konvensjonelle teknikker i ny kombinasjon er det mulig å produsere kopper av avløpsvann fra norske gruver.



Vannforurensning fra Christianus Sextus gruve ved Røros. Foto: Rolf Tore Arnesen

## Akvakultur

Etter mange turbulente år har oppdrettsnæringen konsolidert sin stilling som en av Norges viktigste eksportnæringer. Potensialet for fortsatt vekst er stort. Viktige miljømessige utfordringer for bransjen er:

- å etablere godt oppvekstmiljø for å sikre gode og sunne produkter
- å sørge for god og sikker behandling av innløpsvann og avløpsvann
- å forebygge negative miljøeffekter ved oppdrettsanleggene og omgivelsene.

NIVA har bred erfaring i akvakultur gjennom mange års virksomhet vedrørende fisk, skalldyr og alger. Virksomheten dekker alle aspekter av hvordan vannmiljøet påvirker organismer og hvordan selve oppdrettsanlegget påvirker miljøet. I tillegg har instituttet omfattende spesialkunnskap innen en rekke fagfelt som har betydning for oppdrettsnæringen. Det gjelder særlig forholdet

mellom helse og miljø, vannbehandling, studier av sedimenter og dyrking av alger.

NIVA utfører oppdrag for offentlige etater, kommuner og fylker, oppdrettere og industri-

bedrifter i inn- og utland. Av typiske oppdrag kan nevnes studier av miljøeffekter, vannkvalitetsproblemer i oppdrettsanlegg, tekniske løsninger for rensing av avløpsvann, godkjenning av UV-anlegg for inntak av sjøvann til smoltanlegg samt lokalisering av nye anlegg. Instituttet har et akkreditert analyselaboratorium og gode forsøksmuligheter i både ferskvann og sjøvann. NIVA har egne eksperter i Oslo, Bergen, Grimstad, Tromsø og på Hamar, og et omfattende samarbeid med andre fagmiljøer.

## Algekulturteknologi

Algekulturteknologi har som oppgave å nyttiggjøre alger og spesielt blågrønnalger til å fremstille stoffer, modifisere produkter, eller anvende dem for spesielle formål med praktisk og økonomisk interesse.

Mikroalger er en hittil praktisk talt ikke utnyttet ressurs i produksjonsteknologisk sammenheng. Imidlertid har en omfattende

Forskningsstasjon for oppdrett av ferskvannsfisk i Orissa, India. Foto: Bjørn Braaten



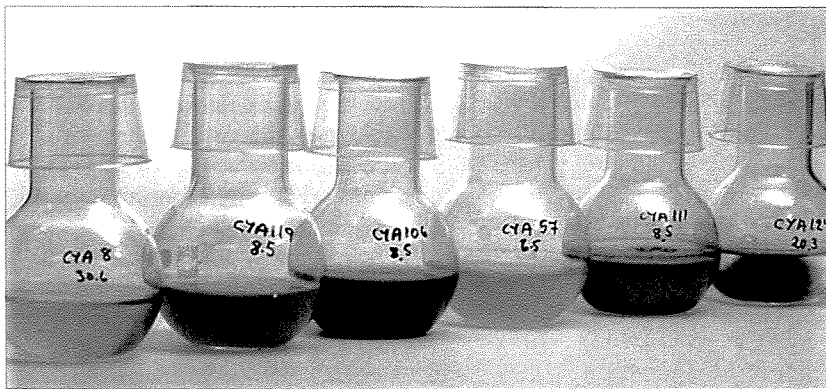

Eksempler på blågrønnalger fra NIVAs algekultursamling som benyttes i algekulturteknologi. Foto: Vidar M. Skulberg

forskningsinnsats fremskaffet grunnleggende kunnskap om deres forekomst, systematikk, fysiologi og økologi. Moderne molekylærbiologi har gjort utnyttelse av mikroalger til et interessant utviklingsområde. Anvendelsen av produktene er allsidig og omfatter næringsmidler og spesialkjemikalier, for eksempel farmasøytiske stoffer. Produksjon av hydrogengass er et annet eksempel på en mulig praktisk anvendelse. Utnyttelse av hydrogenproduksjon kan være et biprodukt ved fremstilling av andre algeprodukter.

Det er spesielt interessant at algekulturteknologien åpner for et integrert industrielt helhetsforetak. I dette inngår også bruken av avfallstoffer som produksjonsfaktorer. Potensialet er særlig stort

i forbindelse med energiproduksjon. Denne produksjonen gir blant annet CO<sub>2</sub>-utslipp og spillvarme som kan utnyttes i algekulturteknologi.

Siden opprettelsen av NIVA i 1958 har instituttet hatt alger som en sentral forskningsinteresse. Dette har gitt NIVA stor fagkynighet med disse organismene, deres egenskaper og muligheter. Samtidig er det bygget opp en betydelig algekultursamling som rommer arter med interessant økonomisk potensiale. Med dette utgangspunktet tegner algekulturteknologien seg som et aktivitetsområde med fruktbare, faglige og praktiske muligheter ved NIVA. Instituttets sentrale oppgave vil være karakterisering og pilotuttesting av fotosyntetiske mikroorganismer for ulike anvendelser.



## Måle- og overvåkingsteknologi

Informasjon om vannmengde og vannkvalitet i vassdrag og i tekniske anlegg er viktig for å sikre god forvaltning av vannressursene og effektiv drift av vann- og avløpsanleggene. Informasjonen kan benyttes til miljøovervåking, tiltaksplanlegging, måling av effekter av gjennomførte tiltak og til driftsoptimalisering. Bruksområdene vil utvides i takt med at nye, brukervennlige sensorer og måleinstrumenter samt EDB-verktøy blir tilgjengelige på markedet til en akseptabel pris.

NIVA har i mange år tilbudt sine tjenester innenfor dette området. Tidligere bestod arbeidet i hovedsak av tidsavgrensede måleoppdrag og kalibrering av kundens eget måleutstyr. Instituttet har egen instrumentsentral og mobilt laboratorium til bruk for dette formålet. I de senere år har NIVA i tillegg deltatt i utvikling og idriftsetting av komplette systemer for overvåking/informasjon, planlegging og styring/driftsoptimalisering. Et eksempel på dette er ENSIS, et system for miljøinformasjon om vann- og luftkvalitet som ble demonstrert under OL'94 på Lillehammer. I slike prosjekter kombineres bruk av automatiske måleinstrumenter, informasjonsteknologi og vannfaglig kompetanse.

Målestasjon under Beyerbrua, hvor OVA overvåker Akerselva.

Foto: Arne Veidel

**NIVA**  Norsk institutt for vannforskning

Brekkeveien 19  
Postadresse:  
Postboks 173 Kjelsås  
0411 Oslo  
Telefon 22 18 51 00  
Telefax 22 18 52 00

## **Appendix 5: Presentations at NIVA Seminar**

## NIVA - SEMINAR

Manday, 21th of August 1995

11:30 - 13:00, meeting room - 1st floor

Prof. K. UKLEJA

dr. ing. J. ROGUT

M.Sc. A. GRZELAK

- 1. Use of electro-kinetics for improvements of grouts and clean-up chemicals at hazardous waste sites*
- 2. Removal of heavy metals from aqueous waste streams in hollow fibre extractor of textile form*
- 3. Possibilities of utilization of brown caol in agriculture, ecology and breeding*

POLTEGOR, The Mining Institute, Wroclaw, Poland



**USE OF ELECTRO - KINETICS FOR IMPROVEMENT  
OF GROUTS AND CLEAN - UP CHEMICALS  
AT HAZARDOUS WASTE SITES**

by  
**Kazimierz Ukleja**  
**Poltegor Institute**  
**51-616 Wrocław, Poland**

**Wrocław (Poland), Cincinnati, OH (USA) - 1994**

## 1. INTRODUCTION

The adverse environmental impact of industry is mainly caused by emission of gasses, dusts, and solid or liquid waste. Some land areas serving special functions for large urban agglomerations should be particularly well protected from the industrial emissions. In the case of Wrocław, such area requiring special protection is the region of water intakes serving the 800,000 population of the city.

The ferrochromium metallurgical plant Siechnice, closed only in 1990, and still functioning heat-and-power plant Czechnica are located next to the water bearing areas that supply the drinking water for Wrocław. These plants have been placed at the eastern outskirts of the town, on its 'lee' side. Most of the dusts and ashes are carried away from Wrocław. Some of the pollution is returned to the water intakes by the river Oława and other water courses. The effects of solid waste disposed of on a heap are continuous and independent of the action of wind. The direction of underflows in drainage basins of Odra and Oława is disadvantageous for Wrocław. Polluted ground water migrates towards its drinking water intakes.

The disposal of solid industrial waste on the heap, which originates from before the World War II (carbide production), was continued in the years 1945-1990 when the heap was used for ferrochromium furnace slag of the Siechnice plant. The heap is located 500m off ponds that feed ground waters used by drinking water intakes. The degree of soil pollution arising from the operation of the metallurgical plant and presence of the slag heap depends on the distance from the source of contamination and wind direction.

Reconnaissance measurements which were carried out during the initial phase of the research (1990) around the time of closure of the plant showed:

- contamination of soil surface (0-10 cm) on site of the ferrochromium works of ca. 8,000 ppm,
- contamination of soil surface (0-10 cm) on the 'lee' side of the heap of ca. 2,500 ppm,
- pollution of the farm land on the 'lee' side of the heap near the infiltration ponds amounting to 300-600 ppm,
- pollution of the farm land on the 'weather' side of the heap near the infiltration ponds amounting to 150-300 ppm,

The latest research carried out in 1992, two years after the shutdown of the furnaces did not show any significant shift in the level of pollution with chromium compounds.

The potential risk of the contamination threatening the water intakes led to the shutdown of the ferrochromium works. The heap of furnace slag remained in place but its surface was covered with humus. Divergent opinions of experts leave the question of removal of the heap open. It is unlikely that such decision will be made in the nearest future. The research described hereby was undertaken with regard to the hazard that the chromium accumulated in the soil and sediments in rivers and ponds still presents to the drinking water intakes of Wrocław. The investigation focused on:

- inhibition of leaching of chromium and other heavy metals into ground water with the use of electro-kinetics,
- inhibition of leaching of chromium and other heavy metals with the use of mineral sorbents (limestone dust, dolomite dust), organic sorbents (lignite, peat, gyttja), reducing agents (phosphorus compounds, iron, synthetic zeolites),
- sealing of the soil environment in order to prevent migration of impurities into the ground water,
- hydrotechnical engineering projects preventing contamination of soil and ground water with heavy metals,

Stage I (1.04.1990-31.03.1991) consisted of an analysis of the subject under consideration, reconnaissance measurements and calibration of laboratory set-ups.

Stages II and III (1.04.1991-31.03.1993) consisted mainly of laboratory research and supplementary peripheral investigations.

Stage IV (1.04.1993-31.03.1994) consisted of field tests and supplementary laboratory research.

The research work was carried out in three yearly stages, each ended with an interim report. The fourth, final stage comprised field tests and elaboration of the final report.

## 2. SUMMARY OF INVESTIGATION AND CONCLUSIONS

The results of measurements consider the water bearing areas of Wrocław (ca. 700,000 inhabitants), which have been contaminated for many years by gasses and dusts from the ferrochromium plant Siechnice and heat-and-power plant Czechnica, located in the immediate proximity of the water intakes of Wrocław. Furthermore, the settlements: Radwanice, Siechnice and Czechnica are located next to these water bearing areas. These settlements do not have sewerage systems.

The following issues must be taken into consideration when discussing the results of the measurements:

- hydrogeological, hydrotechnical and weather conditions in the investigated area,
- consequences of industry and its infrastructure in the investigated area,
- a degree of natural environment devastation,
- reconnaissance measurements in the area of influence of the metallurgical plant and the heat-and-power plant and creating the methodology of laboratory measurement,
- verifying field measurements,
- methods of restoring an ecological balance in the investigated area.

The results of the laboratory and field tests as well as conclusions drawn from them must be related to the natural conditions in the investigated area, which are as follows:

- an aquifer in the area of the water intakes consists of impermeable formations, not covered with an insulating layer (e.g. clay); it favors contaminants' migration from the surface to ground water, which makes a drinking water source,
- the terrain surface, as well as the aquifer slope down to the water intakes; it favors contaminants flow in surface and ground water towards the drinking water intakes, (fig. 4).
- location of the metallurgical plant, heat-and-power plant and the heap of slag and refuse from these plants and also location of the settlements without the sewerage systems favor the contaminants migration (mainly heavy metals) in ground water to the water intakes,
- a water course - Koci Rów - collecting surface water from the plants' area flows through the water bearing area; its sediments have high concentrations of the heavy metals, mainly Cr, which exceeds 300 times the standard for soils. The bottom sediments of Koci Rów, so called the GL VIII soil, as well as bottom sediments in ponds feeding the aquifer contain large quantities of the heavy metals which must be periodically removed in a way that prevents their return to the ground water. This was the reason that "bottom water", as a particularly good contaminants' carrier, was subjected to comprehensive laboratory and field tests. The tests were carried out for various filtration conditions, which slowed down or sped up the migration of the heavy metals through a specific arrangement of soil layers,
- the ground in the area of the metallurgical plant, highly contaminated with Cr in 0-10 cm top layer (7,500 ppm), so called the GL VI soil, presented a big hazard for the drinking water intakes. It was subjected to comprehensive field tests. The tests were carried out in order to find a method to reduce the chromium leachability from the highly contaminated top layer of the soil to the ground water. In order to reach the chromium leachability complying with the standard for drinking water various sorbents were added and the DC electric field  $E_2$  was applied.

- the ground base exposed to direct influence of the metallurgical plant and slag heap is heavily contaminated with Cr (2,640 ppm) in the surface layer of soil (0-10 cm). The ground was called the GL VII soil,; it presents an important ecological problem, calling for the comprehensive laboratory and field tests. The Cr leachability was attempted to be minimized by adding heavy metals sorbents and applying the DC electric field  $E_2$  to the top layer of the soil (0-10 cm).
- the soil of the remaining part of water bearing areas, so called GL I to GL IV (150-1,000 ppm Cr in the top layer), was subjected to the comprehensive laboratory measurements in order to find a best method of minimizing the Cr leachability. Various sorbents were used in various proportions as well as various intensities of DC:  $E_0$ ,  $E_1$ ,  $E_2$ ,  $E_3$ .
- applying various moderating sorbents or additives increasing the Cr leachability to ground water required a comprehensive examining of the chemical composition of all used media. It was necessary in order to find out whether their addition would not create an ecological threat,
- the field measurements, carried out for GL VI and GL VII, going on for the whole year 1993 and first quarter of 1994, required systematic meteorological measurements, containing the following values: rainfall, air temperature, dustiness of the air and the chemical composition of rain water and air,
- the chemism of vegetation on the slag heap and around it was also examined.

The many years' adverse impact of the metallurgical plant, the heat-and-power plant and their infrastructure caused deterioration of natural environment (soil, surface water and, partially, ground water) in the area of the water bearing areas serving Wrocław.

Natural conditions, discussed above, like: geological structure, hydrogeological and hydrotechnical conditions, terrain morphology and location of contaminants' sources required a specific methodology of research:

- Large areas of ground, having a different degree of ecological devastation, limit the methods of soil reclamation to mixing it with media sorbing contaminants.
- Heavily polluted grounds (e.g. bottom deposits of water courses) require removing beyond the area of an adverse impact and reclamation by mixing with appropriate media and applying the electric current.
- Another research issue is choosing appropriate sorbents and applying optimum intensity and direction of the DC electric field to the contaminated ground.

Therefore the laboratory tests and the verifying field tests were preceded by reconnaissance and supplementary tests. Their objectives were:

- preparing of test stands and appliances,
- chemical examination of neutralizing media,
- examination of an influence of electric field' intensity and direction.

The rest of the chapter discusses conclusions drawn from the measurements. The conclusions are grouped in three sections according to order of their implementation:

- reconnaissance and supplementary tests,
- laboratory tests,
- verifying field tests.

### 2.1. Conclusions concerning the reconnaissance tests and methodology of laboratory research

The related research work, preceding the present measurements described various facts about a degree of contamination with heavy metals (mainly Cr) of soil, surface and ground water and biota of the investigated region. These facts were often incoherent. Only the

extreme values of contamination were presented and on the ground of them the general conclusions were formulated, sometimes terrifying sometimes reassuring.

The purpose of measurements discussed in the present chapter was the investigation of:

- distribution of soil contamination a horizontal layout: from sources to the outskirts of influence,
- vertical distribution of contaminants in a laminar arrangement of the soil base and the physical properties of the soil layers,
- distribution of contamination with heavy metals in water courses bottom sediments and ponds,
- distribution of contamination with heavy metals of rain water, surface water, run-off water, ground water in the roof layer and the sole of the aquifer.

The following conclusions were drawn:

2.1.1. In the horizontal layout the highest contamination of soil with chromium was found on the terrain of the metallurgical plant (area of ca. 0.3 km<sup>2</sup>). It amounted to ca. 7,500 ppm Cr, then decreased to ca. 2,500-1,000 ppm Cr in the proximity of the plant (200-500 m), then further decreased outside this area from the value of 1,000 ppm Cr to 150 ppm Cr in the 1,000-5,000 m distance from the source. The above-mentioned areas are of irregular shapes, reflecting the prevailing wind directions.

2.1.2. It was proven that in the vertical layout of the granite base, the heavy metals (mainly Cr) accumulated in the upper layer of the (0-10 cm) and then, with time, moved slowly into deeper soil layers (10-25 cm), and finally to the subsoil at the rate of 15 ppm/year/10 cm downwards. The process took place in a sandy soil, without any cultivation or farming. Migration of increased charge of Cr<sup>+6</sup> in relation to total Cr was discovered.

2.1.3. The contamination of bottom deposits decreased as the distance from the metallurgical plant increased. In the plant's area it amounted to 11080 ppm Cr and at the outlet of Koci Rów to Zielony Potok - 57 ppm Cr. It means that the bottom deposits of Koci Rów carry large charge of heavy metals, mainly Cr, and that they may be an important subject of research into the ways of heavy metals neutralization.

2.1.4. The bottom deposits in the settlement ponds showed high concentrations of the heavy metals. These deposits need to be removed and subjected to neutralizing processes.

2.1.5. Rain water was examined twice: at the beginning of research when the plant was at work (1990) and in 1993 during field tests. In the first period the pH of rain water ranged between 7.1 and 9.42 and the concentrations of the heavy metals slightly exceeded the standards for drinking water. In the second period the rain water showed the pH of 4.1 to 5.0 and the heavy metals concentrations within the standards. Water of pH of 4.15 was used to the laboratory tests of Cr and other heavy metals leachability.

2.1.6. Run-off water showed large content of sulfates (exceeding the standard) and the concentrations of Mn, Hg, Cr and Ni slightly above the standard.

2.1.7. Surface water, retained in filtration ponds and a pond close to the plant is of relatively satisfying quality, and is classified as the first class surface water (Polish national standard). This is the evidence that heavy metals' ions quickly precipitate in stagnant water and then fall down with the slime. It also explains the high concentration of heavy metals in bottom sediments.

2.1.8. Ground water in the roof layer and the sole of the aquifer showed the contents of Fe and Al far above the standard. The  $\text{SO}_4^{2-}$  content was much higher for water in the roof layer than that in the sole of the aquifer.

In the roof layer water the cadmium content was found to exceed the standard. In several piezometers the concentrations of zinc and copper exceeded the standard. The rest of heavy metals were below their standards.

2.1.9. The reconnaissance measurements of heavy metals concentrations in wild vegetation in the neighborhood of the plant showed that Cr and Zn concentrations slightly exceeded the standards. Rest of the heavy metals (Hg, Cu, Pb, Ni, Cd, Co) were below the standard levels.

2.1.10. Because of large areas of contaminated soil and because of the soil's small thickness (10 cm) mixing with its natural sorbents was proposed. The sorbents were used for slowing the process of chromium leaching till the standard values could be reached. The following sorbents were applied:

- all sorts of brown coal found in Poland, which have high content of humic acids,
- dolomite dusts,
- fine fractions of dusts from brown coal burning,
- peat and gytia from Konin area,
- limestone dusts from Tarnów Opolski,
- Tertiary silts from "Turów" brown coal mine .

2.1.11. Bottom slime in the water courses and ponds is also dangerous. It can be reclaimed by using various techniques:

- sealing with silts,
- sealing with acrylate sorbents (acrygels),
- applying the DC electric fields with various intensities:
  - $E_0 = 0 \text{ V/cm}$ ,
  - $E_1 = 0.2 \text{ V/cm}$ ,
  - $E_2 = 0.4 \text{ V/cm}$ ,
  - $E_3 = 0.8 \text{ V/cm}$ .

2.1.12. Because ca. 125 laboratory tests of the Cr leachability were to be carried out (various soils mixed with various sorbents), a special stand containing 12 lysimeters had to be constructed. Each lysimeter could be adapted to serve as electrolysimeter by attaching carbon electrodes. The electrolysimeter enables electric field action ( $E_0$ - $E_3$ ) on the examined soil-water system, representing in a small scale the real arrangement of the ground layers and the intended reclamation process in a contaminated soil or ground water.

The electrolysimeters test stand (see fig. 5) required a long period of reconnaissance measurements and calibration in order to secure the conditions imitating those of filtration processes in the ground. Eventually the following assumptions were made:

- the water pH equal to 4.1, which corresponds to the pH of rainfall in this area,
- action of three intensities of electric current:  $E_1 = 0.2 \text{ V/cm}$ ,  $E_2 = 0.4 \text{ V/cm}$ ,  $E_3 = 0.8 \text{ V/cm}$ ,
- height of lysimeters equal to 50 cm, which corresponds to the soil and subsoil layer thickness and the slime layer in Koci Rów water course,
- volume of water flowing through the lysimeter corresponds to the total annual rainfall in this area,
- rate of daily input corresponds to the maximum daily rainfall, water is fed by the use of a dropper,

- prevention of rapid water flow along the lysimeter walls,
- use of carbon electrodes in order to preserve the filtrate from the possible contamination with metals released from metal electrodes,
- prevention of uncontrolled filtrate evaporation during the tests, which could distort the results.

2.1.13. The stand for field tests of the ground base enabled simultaneous measurements of eight different ground bases. Each field lysimeter had a form of a cube, 100x100x100 cm and contained a sector of the ground base of 1 m<sup>3</sup> of volume, which assured:

- simulation of a fragment of the base and ground breed,
- modelling any configuration and intensity of electric field,
- monitoring of the effects of many years' environmental impact on processes taking place in the soil and the ground base, suppressing the external influence effects,
- full insulation of the examined ground fragment from the influence of adjacent ground layers,
- monitoring of chemical processes in the ground and the effects of leaching of chemical compounds from the soil and the ground base to the ground water.

2.1.14. The stand for field tests of bottom slime of water courses and settlement ponds comprised five circular tanks of 0.5 m in diameter and 1.0 m high, which enabled simultaneous measurements of five different arrangements of slime layer and tank bottom, full-sized and made of natural formations.

The stand, shown on fig. 15, enables:

- modelling the sediments layers of natural thickness, on the natural ground bases under the sediments layers,
- modelling the slime layers mixed with various media reducing heavy metals or any other contaminants migration,
- modelling any configurations and intensities of electric field.

## 2.2. Conclusions concerning the laboratory research ( fig. 6÷10).

The main idea of laboratory research was defining the leachability of heavy metals, mainly chromium, from the grounds of various degree of contamination, mixed with various neutralizing media, subjected to various electric fields ( $E_0$ ,  $E_1$ ,  $E_2$ ,  $E_3$ ), with the same boundary conditions in all tests. The Cr contents in the filtrates in relation to required standard for drinking water were to compare.

The tests results are summarized below:

2.2.1. 25 tests were carried out for the GL II soil (146 ppm Cr). The smallest leachability was obtained with 5% addition of the brown coal from Sieniawa to the surface layer of the soil, both with and without electric field. Slightly higher leachability was found for tests when the brown coal from Lubstów or Turossów silt were added. The action of electric field significantly reduces the leachability, satisfying the standard for  $E_3$ .

The addition of brown coal airborne ash or dolomite dust does not reduce the Cr leachability, but raises it slightly in relation to the control test.

2.2.2. 22 tests were carried out for the GL III soil (7,000 ppm Cr). Positively the smallest Cr leachability (around the standard) was obtained for the brown coal from Sieniawa and  $E_0$ , as well as for currents  $E_1$ ,  $E_2$ ,  $E_3$ . The leachability was 15 times smaller than the control test in this case.

The rest of tests with the addition of: bentonite, limestone dust and zeolites, showed the Cr leachability around that of the control test, exceeding the standard from 10 to 12 times.

The addition of sodium hypophosphate increases the chromium leachability ca. 3 times. This phenomenon may be used for increasing the rate of Cr leaching, e.g. from the bottom deposits subjected to reclamation.

The influence of the electric current ( $E_1$ ,  $E_2$ ,  $E_3$ ) clearly reduces the Cr leachability, satisfying the standard for  $E_2$  and  $E_3$ .

2.2.3. 17 tests were carried out for the GL IV soil (1,470 ppm Cr). It appeared from them that addition of various sorts of the brown coal (Bełchatów, Łęknica, Zebrzydowa), without the electric current, significantly reduced the Cr leachability in relation to the control test. The best results, below the standard, were obtained for the brown coal from Łęknica. Other sorts of coal managed to reduce the leachability to the values exceeding 2-4 times the standard.

The brown coal from Zebrzydowa did not reduce the Cr leachability in relation to the control test. The leachability was in excess of the standard by a factor of 12. Similar results were obtained for the Bełchatów brown coal modified with  $Fe^{+3}$  iron ions. The electric field action reduced the Cr leachability significantly in all tests. The best results were obtained with the brown coal from Zebrzydowa, especially for  $E_3$  the Cr leachability decreased 15 times, falling below the standard.

2.2.4. The GL V soil sample (770 ppm Cr) was subjected to 13 tests. Peat and gytia were added. It was found out that these mixtures demonstrated high leachability, exceeding the standard by a factor of 12 to 15. The electric field, especially  $E_3$ , causes a serious reduction of the Cr leachability, remaining close to the standard in all tests..

2.2.4. The GL VI soil (7,500 ppm Cr) was examined in four tests in two phases, separated by a one-month's intermission. The investigation showed that because of high pollution of the soil the introduction of sorbing additives: brown coal (5%), acrygel K-14 (3%) or the electric field action ( $E_2$ ) did not allow to reduce the Cr leachability below 10 times the standard for drinking water.

The most efficient sorbent was a brown coal, which reduced the Cr leachability by a factor of 3 in relation to the control test. The monthly intermission did not influenced the Cr leachability.

2.2.5. The GL VII soil (2,460 ppm Cr) was also examined in four tests in two phases with a one-month's intermission.

The investigation showed that also for GL VII the addition of the brown coal, acrygel K-14 or the electric current  $E_2$  action on the top soil layer (0-10 cm) could not reduce the Cr leachability to the required standard value. In the initial stage the Cr leachability was reduced to 2.5 times the standard value, in the final stage to 7 times the standard. The monthly intermission did not influenced the Cr leachability.

2.2.6. Bottom sediments of Koci Rów, the so-called GL VIII soil (10,000 ppm Cr) was subjected to 24 tests, with the use of: brown coal, limestone dust, acrygel K-14. In all tests the electric current ( $E_0$ ,  $E_1$ ,  $E_2$ ,  $E_3$ ) was applied.

The effluent from the lysimeters showed much higher amounts of Cr from the soil with super-sorbent K-14 than for the control test.

The action of  $E_0$ - $E_2$  raised the Cr leachability; further increase of the electric current intensity to the value of  $E_3$  caused slight reduction of the Cr leaching rate. The electric field  $E_1$ - $E_3$  increased the Cr leachability in relation to the "no electric field" test or the control test.

2.2.7. In order to establish the sorptive capacities of the brown coal from Bełchatów and Sieniawa 8 tests were carried out: 4 with coal from Bełchatów and 4 with coal from Sieniawa.

The investigation showed that:

- both kinds of the brown coal have the same sorptive capacities of Cr,



- the brown coal from Bełchatów is better from the economical point of view (much cheaper),
- usefulness of the brown coal as a Cr sorbent is beyond doubt; however, it decreases with time.

In spite of high contamination of the filtered water with heavy metals (Cr, Cd, Cu, Pb) it was possible to maintain the Cr leachability around the standard for drinking water for 3 months. After this period the Cr leachability raised to the value of 3 times the standard.

### 2.3. Conclusions concerning the field tests of the Cr leachability from the contaminated GL VI and GL VII soils ( fig. 11÷14).

The purpose of field measurements was to verify the results of the Cr leachability, obtained in laboratory tests, for the GL VI and GL VII soils. The following assumptions were made:

- original arrangement of soil layers was preserved as well as natural dimensions in the test stand,
- tests carried out in a natural atmospheric conditions: air temperature, rainfall, air and rainfall pollution, insolation,
- prevention from any external influence,
- research period covering all seasons of the year.

The measurements of the leachability of the GL VI i GL VII soils were carried out in 8 field lysimeters: GL VI (7,500 ppm Cr) in lysimeters 1-4, GL VII (2,460 ppm Cr) in lysimeters 5-8. The conclusions drawn from the field tests are described in the rest of this section.

2.3.1. Lysimeter 1 contained soil GL VI without chemical additives and E<sub>0</sub> (no electric field). the results were regarded as the control test. The results indicated that the soil from the most contaminated places, represented by the sample GL VI (7,500 ppm Cr) showed the Cr leachability exceeding 4.5 times the standard for drinking water. In consequence the ground water feeding the drinking water intakes are constantly contaminated with that intensity and no steps are taken to reduce the Cr leachability.

2.3.2. Lysimeter 2 contained soil GL VI mixed with 1% of acrygel K-14 (supersorbent) in the upper layer (0-10 cm). Addition of acrygel increased the span between the extreme values of leachability in relation to the control test, whereas the average value was similar to that of the control test. It is characteristic that the Cr content was higher in winter months in relation to summertime.

2.3.3. Lysimeter 3 containing soil GL VI was free from chemical additives but was subjected to electric current E<sub>2</sub>. The investigation proved that the Cr content in the effluent decreased continuously to a value below the standard. The periods of no effluent were much shorter than in the control test and the extreme daily leak-out volumes were much smaller. It is evident that the electric current stabilized the effluent rate and Cr content in the effluent.

The investigation carried out with lysimeter 3 showed significant reduction of the chromium content in relation to the control test and also increased water retention capabilities of soil.

The influence of the electric field E<sub>2</sub> caused, in the final stage of measurements, the GL VI soil sealing resulting in effluent termination and water remaining on the soil surface.

2.3.4. Lysimeter 4 contained the GL VII with 10% addition of the brown coal in the soil upper layer (0-10 cm). The results imply that:

- brown coal reduced the Cr leachability by 23% on average in relation to the control test; the leachability at the beginning of the test was much lower than the average (by a factor of 1.5)

- whereas the leachability in the final stage was higher than the average by a factor of 1.5,
- a sweeping reduction of the chromium leachability from highly contaminated soil would require increasing the dose of brown coal.

Determining the optimum dose and frequency of application would require additional research.

2.3.5. Lysimeter 5 contained soil GL VII (2460 ppm Cr) without chemical additives or electric field. The results were regarded as the control test. Grunt GL VII represented highly contaminated areas of the agricultural land, with an impermeable sandy clay layer. The investigation proved that the impermeable layer and the soil efficiently reduced the Cr migration to the ground water to the values within the standard.

It is probable that this phenomenon will not last long. After a period of time (several years) the sorptive capacity of such a soil may be exhausted.

2.3.6. Lysimeter 6 contained soil GL VII with 1% of acrygel K-14 in the top layer of the soil (0-10 cm). The tests showed that the average Cr content in the effluent was similar to the results of the control test. In the last stage of research (winter) the chromium content decreased to the value below the standard, whereas values obtained for the control test increased by 50%.

The investigation showed:

- acrygel K-14 increased by 22% water content of the soil top layer, which is important for vegetation growth,
- leachability of Cr is analogous to the control test,
- Cr content in the effluent remains below the standard for drinking water.

2.3.7. Lysimeter 7 contained soil GL VII without any chemical additives but electric field  $E_2$  was applied. It was found out that:

- average increase of the Cr content by ca. 40% in relation to the control test,
- significant prolongation of effluent period after each rainy period in relation to the control test (to almost 9 months per year),
- systematic increasing of the effluent volume to stopped completely in the final stage of research, when water began to accumulate on the top of the lysimeter.

One year's period of the electric current  $E_2$  action caused the complete sealing of the GL VII soil.

2.3.8. Lysimeter 8, contained soil GL VII with 10% of the brown coal in the soil top layer (0-10 cm). The tests showed that:

- Cr content in the effluent increased by 28% in relation to the control test,
- water content of the soil increased by ca. 11%,
- water retained capabilities of the soil increased; there was no effluent for ca. 9 months/year and the total effluent volume was very small.

The research at lysimeter 8 showed that the brown coal raised agricultural properties of the soil and reduced the filtrate volume thus reducing the total amount of the Cr charge to the value analogous to the control test.

#### 2.4. Conclusions concerning the field tests of the Cr leachability from the bottom deposits of Koci Rów - GL VIII soil (11,000 ppm Cr), (fig. 45 ÷ 49).

The purpose of this investigation was testing of the Cr leachability from the bottom slime of the water course Koci Rów. The following tests were carried out :

**REMOVAL OF HEAVY METALS ( Hg, Cr, Pb and Zn ) FROM AQUEOUS  
WASTE STREAMS IN HOLLOW FIBRE EXTRACTOR  
OF TEXTILE FORM**

**U.S. - POLAND MARIA SKLODOWSKA - CURIE JOINT FUND II  
PROJECT PROPOSAL**

Principal Investigator on Polish side:

**Jan Rogut, PhD**

**Poltegor Institute  
Wroclaw, Poland**

Principal Investigator on U.S. side:

**Subhas K. Sikdar, D. Sc.**

**Risk Reduction Engineering Laboratory  
EPA, Cincinnati - Ohio, U.S.A.**

**2. CONTENTS:**

- 1. Cover sheet**
- 2. Contents**
- 3. Summary of the project**
- 4. Detail description of the project**
- 5. Literature**
- 6. Curriculum vitae of the Principal Investigator**
- 7. Project budget summary**

### 3. SUMMARY OF THE PROJECT

Pollution of the water streams and water - soil environment by heavy metals, the result of the long term non responsible industrial and military activity of humans belongs actually to the most dangerous health's hazards to peoples world-wide. Elaboration of the effective but inexpensive methods of removal of heavy metals from soil and water sources is very difficult but of top priority target of the modern environmental science and technology. The recent inventions from the membrane technology, as disclaimed in recent US Patents: ( *5,238,562 from 24 Aug. 1993* *5,284,583 from 8 Feb. 1994* , *5,328,610 from 12 July 1994* and *5,332,498 from 26 July 1994* ) by **J. Rogut** are assumed to be the instruments of solving the problem effectively.

The project proposals assume employing the novel textile forms of hollow fibre membranes , to built the effective but inexpensive extractors ( liquid - liquid membrane contactors ) able remove selectively the ions of heavy metals from water waste streams and from the water solutions produced in the soil regeneration processes. The results of the project looks be also of future practical importance as the alternative way of removal of soluble heavy metal components leacheable from fly ashes and from deposits produced during combustion of solid communal wastes.

The basic part of the experiments will be carried out, using small laboratory scale systems, but after obtaining the positive results , the best construction will be repeated as the enlarged unit to be used in tests under field conditions. It is assumed, that the prototype unit of the membrane extractor unit of productivity of one cubic meter of detoxified water per hour will be built as the final product of the proposed research. The main part of work will be conducted in Poltegor Institute, Wrocław, Poland, although, the valuable independent parallel tests will be also carried out in EPA, Risk Reduction Engineering Laboratory in Cincinnati, USA ( Dr. Subhas K. Sikdar ). The membrane materials used in tests will be of Polish production, although, some membranes of the best world manufacturers ( Hoechst Celanese and Akzo ) will be also employed for comparison.

## **Possibilities of Utilisation of Brown Coal in Agriculture, Ecology and Breeding**

Adam Grzelak, Msc

Institute of Opencast Mining, POLTEGOR

Wrocław, Poland

Nearly all brown coal mined actually in Poland is consumed as fuel source for energy generation. The other applications of this raw material in chemical industry especially in production of artificial liquid fuels have been developed on scientific and industrial basis in Germany. The value of brown coal for agriculture applications was the subject of extensive studies by Nowosielski in the Institute of Vegetable Crops in Skierniewice last 35 years. His studies connected with applications of brown coal in agriculture science demonstrated that this material exhibits highly huminous structure. This structure is responsible for excellent natural sorption properties of brown coals. The derived from coal humus can be treated as very valuable component of soil - coal or soil - coal - fertilizer systems. It can be employed as effective carrier for artificial or natural fertile components. In some cases the brown coal itself when contaminated by valuable minerals of basic character can be treated as natural fertiliser. The most important advantages of brown coal applications in agriculture follow from the following reasons:

- increase of soil humidity ( increase of soil capacity to water storage )
- decrease and stabilisation of ionic strength of soil electrolytes
- intensification of process of ion exchange between soil electrolytes and roots of the plants ( replace the hydrogen ions on calcium, magnesium and zinc ions )

Actually, the results of Nowosielski are under the implementation stage and several mixtures those contain brown coal are available in Poland commercially. Unfortunately, because of high production and distribution costs of the production its application is limited in main to supporting only the fruit and vegetable cultures. For broad application of brown coal as fertilizer to grain and to root crop cultures it will be necessary distribute up to 50 metric tons of powdered brown coal on each hectare area. Although potentially very effective such operation looks be unacceptable from economy reasons.

Nearly all brown coal mined yearly in Poland will be consumed on this way. It is important to notice here that some types of brown coal not exhibit assumed fertilising properties ( Turów deposits ).

It has been documented in the studies by Ukleja that particles of brown coal are effective in sorption and immobilisation of ions of heavy metals, in instance of chromium ions from contaminated surface and underground water. Those properties have been found especially sound when looking for the results of the studies of chromium migration in the contaminated soils in the vicinity of Siechnice, the ferro - chrom metallurgy complex, near Wrocław. The immobilisation effect of different natural additives on the migration rate of selected heavy metal ions have been examined experimentally in this area. The best immobilization results against chromium migration has been found after dispersing the brown coal particles over the top layer of devastated soil. The concentration of chromium ions in surface waters decreased fiftyfold ( from 0.50 - 0.01 mg/l ) after distribution the brown coal particles as a top layer. The upper findings document the applicability of the brown coal not only as a valuable component of natural fertilizers but also as the effective immobilizater of ions of heavy metals.

The upper statements argue for broader studies on ecology oriented applications of brown coal, especially in soil and land reclamation on devastated territories. The several important questions arrive in relation to this findings. The first is the real protection time of the coal deposition, i.e., what is the optimal frequency of the brown coal sewing operation on reclaimed areas. The results of the experiments show the procedure needs be repeated each four year. It is because of the sorption capacity of the brown coals against the heavy metal ions. This parameter is directly related to the concentration of acid huminous group on the coal surfaces. From 18 to 82 % of active surface groups on Polish brown coals are the acid huminous one. The brown coals with low content of acid groups are the very weak sorbents of metals.

The next interesting area for non-energy application of brown coals is animal breeding. The pioneering works in this area are connected with Prof. Dobrzański from Agriculture Academy in Wrocław. Brown coal is valuable bedding material as well as the direct component of animal's diet. It has been documented in breeding chicken and

piglets. The components of brown coals influence positively the health of animals, increase the rates of their growth, decrease the anemy. High sorption capacity of brown coal against ammonia improves substantially the microclimate of beddings for animals.

Actually the preliminary studies on employing the brown coal - leaching earth - vegetable fat and oil mixtures as a valuable food for animals are carried out. The oily porous particles of leachable earth are the waste coproduct in refining vegetable oils. The press filter deposits from vegetable oil refining contain from 15 to 25 % of vegetable fats. They can be used as valuable food components but only after necessary redefining the composition of the waste to adopt the properties for animals' needs. The preparations have been tested in feeding animals. The substantial decrease of cholesterol levels in their blood and in meat as well as in medicine consumption were determined during the tests. The preparations contained oily earth particles and brown coal powder as a major components ( 99 % by weight in total ).

The following technical problems were necessary to be solved:

1. The procedure of fast cooling the hot filtrate cakes during removal the oily earth deposits from press filters with simultaneous protection against oxidation of the oil and fats impregnating the particles
2. The right procedure of adequate milling the evacuated deposit
3. The optimisation of composition ratio of brown coal against the earth

The oily earth particles after raffination are the subjects of the fast ageing processes those lead to bacterial and fungi based destructions. When left under elevated temperatures they start to be toxic wastes just after two to ten days of storage. That makes sense of looking for techniques of rapid cooling the removed deposits and of decrease the oxygen contents inside.

We found the following unexpensive measures are effective in solving the upper problems:

1. The fast cooling of the filtration cake just directly during the removal from the press
2. The oxidation rate of the matter decreases substantially by mixing the cake with small amounts of some types of natural zeolites

3. The storage time increases by mixing the earth in right ratio with powdered brown coal

The first and the second from the upper operations can be carried out simultaneously, although mixing and homogenization with brown coal can be done separately later, up to 2 weeks. The produced preparations can be stored and offered as nutritious food up to three months from the production date. We found it is still healthy and valuable product after half year of storage. Our expertise is based mainly on experiments with rape oil. Although the soya oil, linseed oil and sunflower oil can participate in deposits up to 25 % by weight. The noticed by us problem is connected with higher risk of selfignition of those coposition during storage.

About 6000 Mg of those oily leaching earth is produced in Poland yaerly. It makes the raw material basis for production of valuable and healthy food preparations for breeding the 1 % of animals' population in the country solving in parallel the problem of utilisation of the potentially dangerous organic wastes.

## **Conclusions**

1. The results of our studies confirmed the high value of brown coal as natural fertilizer and simultaneously the effective sorbent for immobilization the heavy metal ions in contaminated soil. It can be employed as fully ecological preparation for soil and surface water reclamation.
2. The zootechnical studies carried out with waste leachable earth from vegetable oil raffination processes have demonstrated the high nutritious value. The mixtures of filtration cake with dispersed brown coal is the healthy and stable in time food for breeding animals. This solves effectively the problem of utilisation of those potentially dangerous organic wastes.



## **Appendix 6: Information about SFT**

## State Pollution Control Authority

State Pollution Control Authority (SFT) is under the auspices of the Ministry of the Environment, and plays an important role in efforts to combat pollution, waste problems and noise. SFT is responsible for measures against industrial pollution, oversees the national oil pollution emergency services and administers the Product Control Act. SFT acts as technical advisory agency for the Ministry of the Environment, and is generally responsible for monitoring atmospheric and aquatic pollution. SFT is responsible for issuing guidelines for the county departments of environmental affairs with regard to agriculture, municipal waste, fish farming and hazardous wastes.

SFT functions as the secretariat for the Governmental Action Control Group.



### **SFT State Pollution Control Authority**

Strømsveien 96, P.O. Box 8100 Dep., N-0032 Oslo, Norway

Tel: + 47 2 57 34 00, after 28th Jan 1993: + 47 22 57 34 00

Fax: + 47 2 67 67 06, after 28th Jan: + 47 22 67 67 06, Telex 76 684 sft n

Oil Pollution Control Department, Horten

P.O. Box 125, N-3191 Horten, Norway

Tel: + 47 33 44 161, Fax: + 47 33 44 257

Oil Pollution Control Station, Tromsø

P.O. Box 3310 Grønnåsen, N-9001 Tromsø, Norway

Tel: + 47 83 75 080, Fax: + 47 83 75 083

Oil Pollution Control Station, Mongstad

P.O. Box 51, N-5124 Mongstad, Norway

Tel: + 47 5 36 30 00, Fax: + 47 5 36 09 25

Division for Air Monitoring and Industrial Compliance - Telemark County

Statens Hus, N-3708 Skien, Norway

Tel: + 47 3 58 61 20, Fax: + 47 3 53 00 20

ELLINGSEN, LARSEN & NYGREN A/S, OCTOBER 1992. ILLUSTRATIONS:  
UKRUT, BY PÅL HANSEN. PRINTERS: FOKUSTRYKK A/S. PRINTED ON  
RECYCLED PAPER.

TA 717/1992 E

ISBN 82-90031-61-0

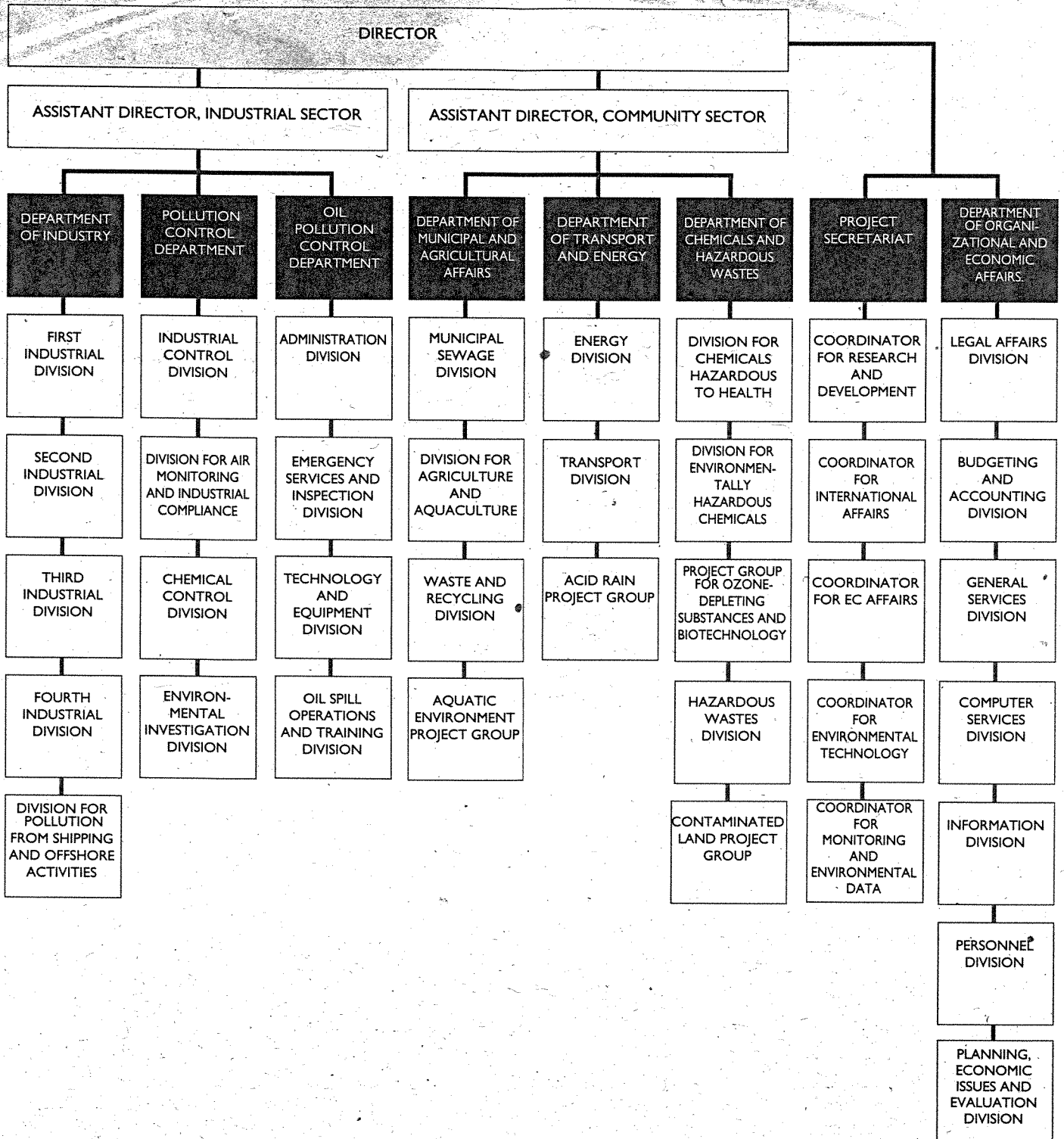
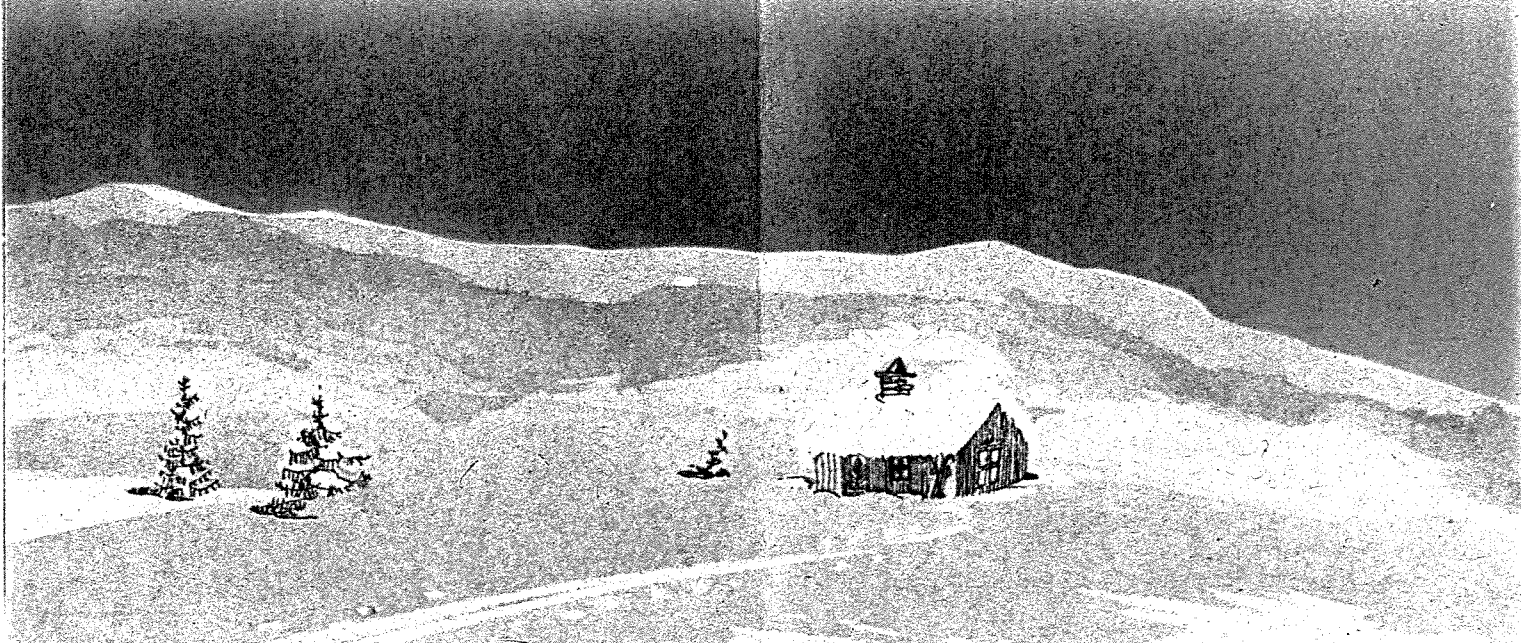



## The Department of Chemicals and Hazardous Wastes

DEPARTMENT OF  
CHEMICALS AND  
HAZARDOUS  
WASTES

DIVISION FOR  
CHEMICALS  
HAZARDOUS  
TO HEALTH

DIVISION FOR  
ENVIRONMENTALLY  
HAZARDOUS  
CHEMICALS

PROJECT GROUP  
FOR OZONE-  
DEPLETING  
SUBSTANCES AND  
BIOTECHNOLOGY

HAZARDOUS  
WASTES  
DIVISION

CONTAMINATED  
LAND PROJECT  
GROUP

is concerned with measures to reduce damage to health and the environment caused by chemical substances and products. (These include substances that deplete the ozone layer, hazardous wastes and products from the biotechnology sector.) The department follows up efforts in connection with national goals and international agreements.

### **The various divisions:**

**Division for Chemicals Hazardous to Health.** Assesses potential health hazards associated with chemicals, including newly-developed substances. This involves classification and labelling, notification systems and restrictions on chemical substances and products.

**Division for Environmentally Hazardous Chemicals.** Surveys and evaluation of possible environmental damage from chemicals and products by material flow analyses, classification and labelling of products and substances, regulation of import, production, sale and use.

**Project Group for Ozone-depleting Substances and Biotechnology.** Assesses and regulates consumption of ozone-depleting substances. Assesses possible environmental hazards from microbiological products covered by the Product Control Act.

**Hazardous Wastes Division.** Issues permits and monitors enterprises included in the system for handling hazardous wastes. Provides guidelines relating to hazardous wastes for county departments of environmental affairs.

**Contaminated Land Project Group.** Responsible for clean-up operations at hazardous waste disposal sites and polluted industrial areas.

**SFT's responsibilities:** SFT is responsible for administering the Product Control Act, and for the regulations relating to hazardous wastes and to exports of hazardous wastes.



## The Department of Industry

DEPARTMENT  
OF INDUSTRY

FIRST  
INDUSTRIAL  
DIVISION

SECOND  
INDUSTRIAL  
DIVISION

THIRD  
INDUSTRIAL  
DIVISION

FOURTH  
INDUSTRIAL  
DIVISION

DIVISION FOR  
POLLUTION  
FROM SHIPPING  
AND OFFSHORE  
ACTIVITIES

handles applications for discharge permits in connection with industrial and offshore activities. About 1,500 enterprises currently have such permits. The department is also responsible for following up permits by reviewing internal control reports and participating in inspections and audits run by the Pollution Control Department. The department administers monitoring of areas which are polluted by industrial and offshore activities, and follows up programmes to develop cleaner technology. The department participates in international efforts to reduce pollution from industry, offshore activities and shipping.

### **The various divisions:**

#### **First Industrial Division.**

Wood-processing industry, pyrites mines, chemical and electrolytic plating, potato processing.

#### **Second Industrial Division.**

Petrochemical, chemical and pharmaceutical industries, printing industry, textile industry, gas-fired power stations.

#### **Third Industrial Division.**

Metallurgical and mineral industry, mining (except pyrites mines).

#### **Fourth Industrial Division.**

Hydrometallurgical industry, oil refineries, paint and varnish industry, rendering plants, foodstuffs industry, fish oil factories, mechanical workshops.

**Division for Pollution from Shipping and Offshore Activities.** Offshore activities, marine pollution from shipping, monitoring of recipients.

**SFT's responsibilities:** According to the Pollution Control Act, any enterprise that pollutes the environment must have a discharge permit. SFT is responsible for issuing such permits for industrial and offshore activities.

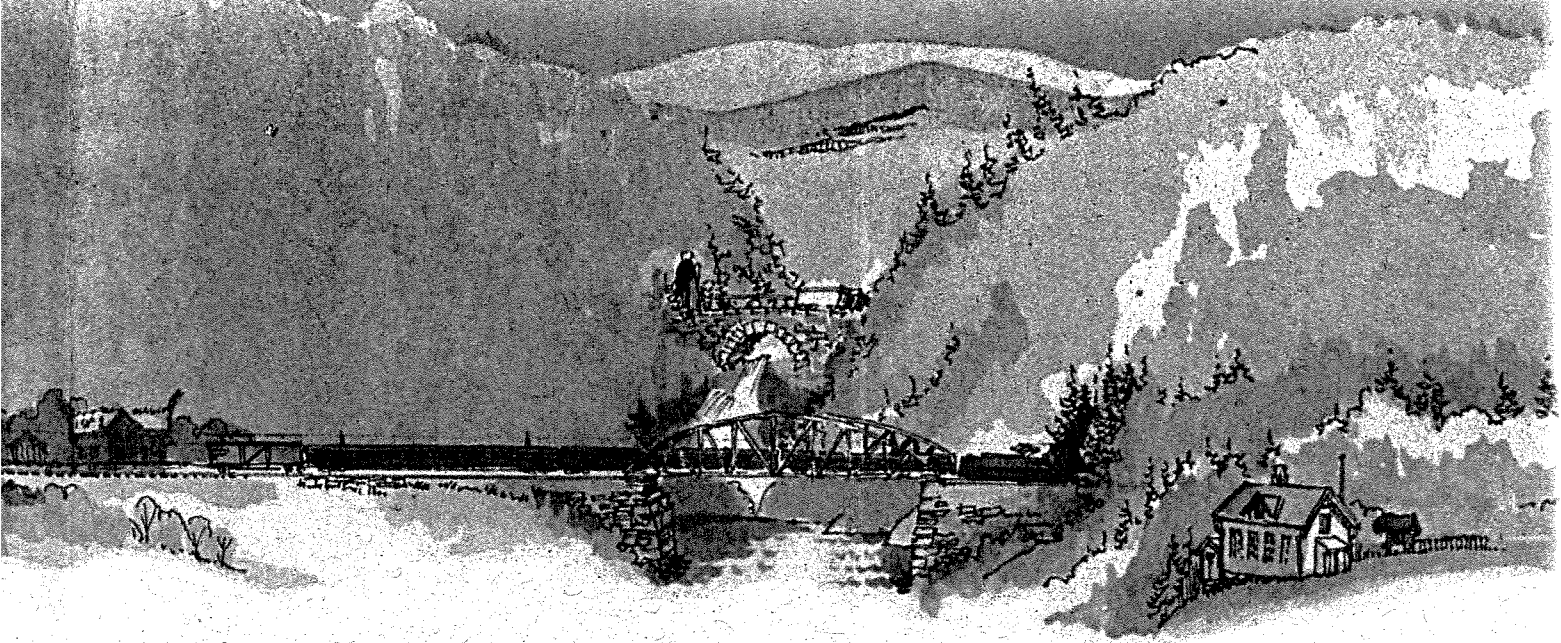

## The Pollution Control Department

POLLUTION CONTROL DEPARTMENT

INDUSTRIAL CONTROL DIVISION

DIVISION FOR AIR MONITORING AND INDUSTRIAL COMPLIANCE

CHEMICAL CONTROL DIVISION

ENVIRONMENTAL INVESTIGATION DIVISION

is responsible for ensuring compliance with the Pollution Control Act, the Product Control Act and any regulations pursuant to these acts, as well as discharge permits to individual enterprises. In addition, the Department identifies risks of accidental discharge and proposes relevant risk-reducing measures.

### **The various divisions:**

#### **Industrial Control Division.**

Monitors compliance with discharge permits by means of inspection, sampling and environmental auditing.

#### **Division for Air Monitoring and Industrial Compliance - Telemark County.**

Monitors compliance and discharges in the heavily industrialized Grenland region. It also operates the monitoring and warning system for air quality in the region, and provides information to the local population.

#### **Chemical Control Division.**

Monitors compliance with the provisions of the Product Control Act and regulations pursuant to the Act by producers and importers of substances that are harmful to health or the environment.

#### **Environmental Investigation Division.**

Called out to investigate the cause of pollution where no obvious source can be found. Provides assistance in the event of accidents involving chemicals.

**SFT's responsibilities:** The department functions as the control agency in most fields where SFT is the control and inspection authority.

## The Oil Pollution Control Department

OIL POLLUTION CONTROL DEPARTMENT

ADMINISTRATION DIVISION

EMERGENCY SERVICES AND INSPECTION DIVISION

TECHNOLOGY AND EQUIPMENT DIVISION

OIL SPILL OPERATIONS AND TRAINING DIVISION

is located in Horten, with two subsidiary oil spill control centres in Tromsø and at Mongstad. Coordinates governmental, municipal and private emergency services and pollution control operations involving oil and other hazardous substances.

### **The various divisions:**

#### **Administration Division.**

Budgeting, accounts, archives, clerical services, planning and administrative support. Takes part in oil spill control operations.

#### **Emergency Services and Inspection Division.**

Stipulates requirements for environmental damage limitation in the case of acute pollution from offshore, shipping, or land-based industry. Controls compliance with required emergency services and stipulates requirements for municipal and governmental emergency services. Surveys shipwrecks and takes part in acute pollution control operations.

#### **Technology and Equipment Division.**

Purchase, inspection and maintenance of governmental oil spill control equipment and depots, technical advice to industry and municipalities. Responsible for governmental oil pollution control vessels and contact with external resources, logistics and use of resources during oil spill control operations. Also responsible for the development of oil spill control technology.

#### **Oil Spill Operations and Training Division.**

Responsible for running oil pollution control operations. Training, exercises and advisory services for private and public emergency services. Responsible for plans and equipment during practical exercises, and for emergency services at the department and the two oil spill control stations. Responsible for running oil pollution control operations.

**SFT's responsibilities:** SFT provides guidance to the authorities responsible for preventing acute pollution. SFT stipulates requirements for emergency services and ensures that these are met. SFT runs oil pollution control operations in cases where the state is responsible for cleaning up spills.

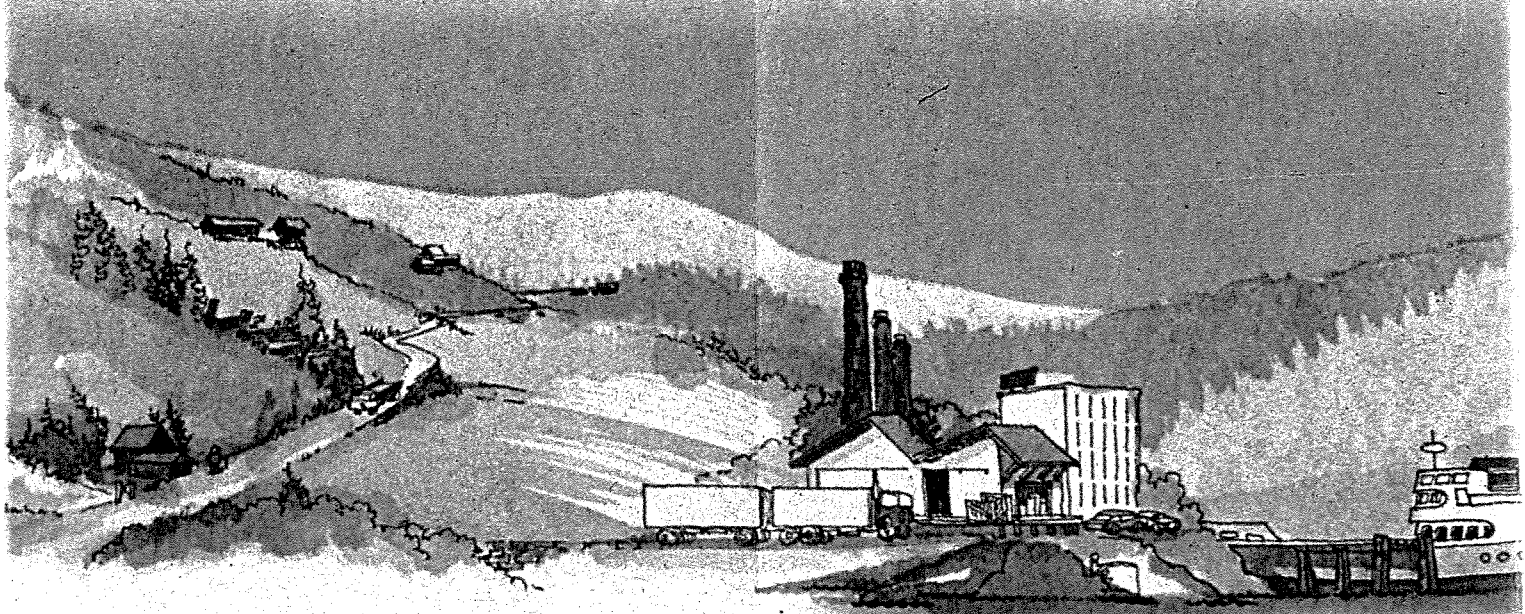

## The Department of Municipal and Agricultural Affairs

DEPARTMENT OF  
MUNICIPAL AND  
AGRICULTURAL  
AFFAIRS

MUNICIPAL  
SEWAGE  
DIVISION

DIVISION FOR  
AGRICULTURE  
AND  
AQUACULTURE

WASTE AND  
RECYCLING  
DIVISION

AQUATIC  
ENVIRONMENT  
PROJECT GROUP

is concerned with discharges to water from municipal sewage, agriculture and aquaculture, and with problems associated with other types of waste and recycling. Draws up cross-sectoral analyses of measures, surveys the state of the aquatic environment, and reports on progress in the implementation of measures. Cooperates closely with the county departments of environmental affairs and coordinates efforts in fields within its sphere of responsibility.

### **The various divisions:**

#### **Municipal Sewage Division.**

National plan for the protection of ground water, municipal sewage treatment plants, treatment and use of sewage sludge. Follows up the North Sea action plan and the research programme for nitrogen removal.

#### **Division for Agriculture and Aquaculture.**

Analyses measures against pollution related to nutrients, erosion, chemicals and antibiotics. Development of purification technology. Proposes anti-pollution measures, reports on their implementation and surveys environmental status.

#### **Waste and Recycling Division.**

Processes licences for waste incineration plants, advises on waste planning, administers state allocations to promote waste reduction and recycling at municipal and industrial level.

#### **Aquatic Environment Project Group.**

Surveys inputs, effects and impacts of nutrient pollution. Follows up the North Sea action plan and proposes long-term environmental objectives and water quality criteria for fresh and salt water.

**SFT's responsibilities:** SFT has assumed responsibility for guidelines for the county departments of environmental affairs with regard to appeals, municipal sewage, waste and fish farming from the Ministry of the Environment. The Ministry proposes environmental objectives, and SFT reviews issues and evaluates measures and goals associated with these.

## The Department of Transport and Energy

DEPARTMENT OF  
TRANSPORT  
AND ENERGY

ENERGY  
DIVISION

TRANSPORT  
DIVISION

ACID RAIN  
PROJECT  
GROUP

is concerned with atmospheric pollution and noise from the transport and energy sectors. The department coordinates cross-sectoral plans to reduce atmospheric pollution and noise. The department is also responsible for other noise-related issues (except permits relating to noise from industrial enterprises) and for work on the long-range transport of atmospheric pollution and its effects on the environment.

### **The various divisions:**

#### **Energy Division.**

Concerned with atmospheric pollution from the energy sector, environmentally-sound energy systems, environmental standards for fuel, and cross-sectoral plans to limit greenhouse gases, SO<sub>2</sub>, NO<sub>x</sub> and VOCs.

#### **Transport Division.**

Efforts to reduce emissions to air from motor vehicles, aircraft and ships. Reduction of noise from motor vehicles, aircraft and railways. Monitors air pollution and noise in urban areas. Draws up environmental quality criteria. Environmentally-sound national and urban transport systems. Effects of and measures to reduce noise from all other sources except industrial noise.

#### **Acid Rain Project Group.**

Concerned with long-range transport of atmospheric pollution, effects on water and soils, and critical loads.

**SFT's responsibilities:** SFT provides guidance for other authorities in the transport and energy sectors. SFT prepares surveys of the state of the environment, assists the Ministry of the Environment in drawing up environmental objectives, and monitors whether these are achieved.



## The Department of Industry

DEPARTMENT OF INDUSTRY

FIRST INDUSTRIAL DIVISION

SECOND INDUSTRIAL DIVISION

THIRD INDUSTRIAL DIVISION

FOURTH INDUSTRIAL DIVISION

DIVISION FOR POLLUTION FROM SHIPPING AND OFFSHORE ACTIVITIES

handles applications for discharge permits in connection with industrial and offshore activities. About 1,500 enterprises currently have such permits. The department is also responsible for following up permits by reviewing internal control reports and participating in inspections and audits run by the Pollution Control Department. The department administers monitoring of areas which are polluted by industrial and offshore activities, and follows up programmes to develop cleaner technology. The department participates in international efforts to reduce pollution from industry, offshore activities and shipping.

### The various divisions:

#### First Industrial Division.

Wood-processing industry, pyrites mines, chemical and electrolytic plating, potato processing.

#### Second Industrial Division.

Petrochemical, chemical and pharmaceutical industries, printing industry, textile industry, gas-fired power stations.

#### Third Industrial Division.

Metallurgical and mineral industry, mining (except pyrites mines).

#### Fourth Industrial Division.

Hydrometallurgical industry, oil refineries, paint and varnish industry, rendering plants, foodstuffs industry, fish oil factories, mechanical workshops.

**Division for Pollution from Shipping and Offshore Activities.** Offshore activities, marine pollution from shipping, monitoring of recipients.

**SFT's responsibilities:** According to the Pollution Control Act, any enterprise that pollutes the environment must have a discharge permit. SFT is responsible for issuing such permits for industrial and offshore activities.

## The Pollution Control Department

POLLUTION CONTROL DEPARTMENT

INDUSTRIAL CONTROL DIVISION

DIVISION FOR AIR MONITORING AND INDUSTRIAL COMPLIANCE

CHEMICAL CONTROL DIVISION

ENVIRONMENTAL INVESTIGATION DIVISION

is responsible for ensuring compliance with the Pollution Control Act, the Product Control Act and any regulations pursuant to these acts, as well as discharge permits to individual enterprises. In addition, the Department identifies risks of accidental discharge and proposes relevant risk-reducing measures.

### The various divisions:

#### Industrial Control Division.

Monitors compliance with discharge permits by means of inspection, sampling and environmental auditing.

#### Division for Air Monitoring and Industrial Compliance - Telemark County.

Monitors compliance and discharges in the heavily industrialized Grenland region. It also operates the monitoring and warning system for air quality in the region, and provides information to the local population.

#### Chemical Control Division.

Monitors compliance with the provisions of the Product Control Act and regulations pursuant to the Act by producers and importers of substances that are harmful to health or the environment.

#### Environmental Investigation Division.

Called out to investigate the cause of pollution where no obvious source can be found. Provides assistance in the event of accidents involving chemicals.

**SFT's responsibilities:** The department functions as the control agency in most fields where SFT is the control and inspection authority.

## **Appendix 7: Information about Elkem Mangan PEA**



Til: Martin  
Fra: Anne K.

**Besøk fra Poltegor (Mining Institute), Polen**

**Dato: 22.08.95**

**Tid: 10.30**

**De som kommer er: Kazimierz Ukleja, prof.dr.hab.ing  
Jan Roput, dr.ing.  
Adam Grzelak, M.Sc  
Grazyna Englund, forsker Norsk  
inst. for vannforskning (Oslo)**

**Program:**

**Kl.10.45: Elkem Mangan PEA - info om  
beriften v/ M.Honstad  
Florten**

**Kl. 11.30: Lunch**

**kl. 12.15: Omvisning PEA v/ Håkon  
Grevstad**

**Kl. 13.00: Miljøforhold v/ A.<sup>Arne</sup>kjellsen**

**Kl.14.00: Avslutning**

**Vi håper på en fin dag på PEA!**

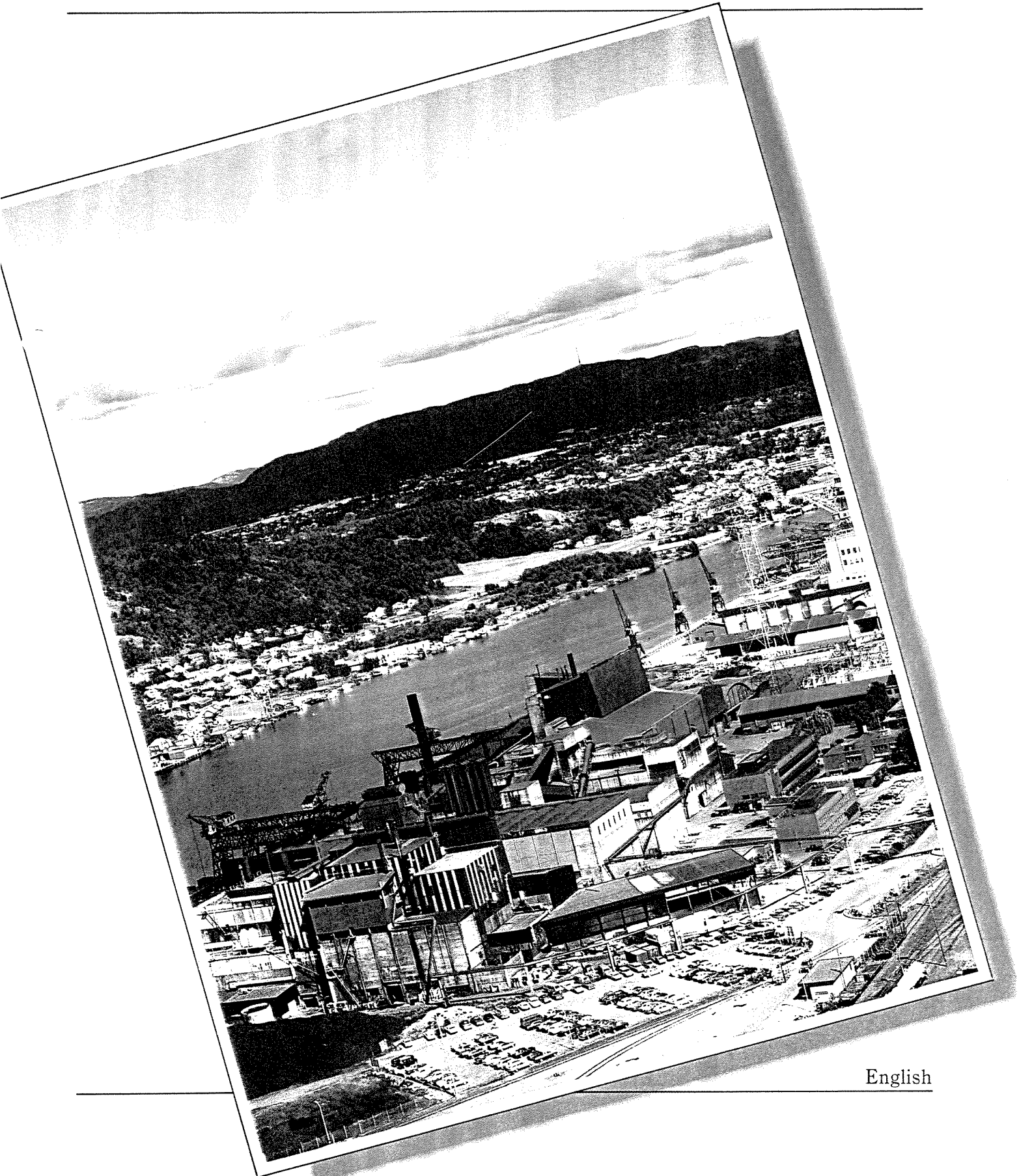

# Elkem PEA

On November 15, 1913, "Porsgrund Elektrometallurgiske Aktieselskab" (PEA) was established in Norway by the Swiss industrial company USINE Electro Métallurgique METEOR SA based in Genova. Meteor had been looking for a suitable location for a new smelting plant in Europe for some time.

The Swiss company chose Herøya in Norway for a number of reasons. It was easily accessible by sea. It was near Porsgrunn, on Norway's eastern coast, about two hours south of Norway's capital, Oslo. And another important consideration was that the local power company, Skiensfjordens kommunale kraftselskap (SKK), was building its first, large power station, and PEA succeeded in signing a 25-year power contract, thus securing a stable supply of electric power.

The smelting plant was designed and built in record time, and a mere two years later, on November 30, 1915, the first tap was taken from the newly installed smelters. Initially, PEA had about 90 employees and produced 5,000 - 6,000 tons of ferro-silicon annually.

SKK's new customer would have a major influence on local developments in the Porsgrunn area in the years ahead. When PEA renegotiated its power contract in 1920, SKK took over 51 percent of PEA's share capital. PEA was now a Norwegian company. SKK kept its share majority until 1966 when Elkem a/s purchased PEA and, changing its name to Elkem PEA, made it a wholly owned subsidiary.

Over the years, Elkem PEA has had to adapt to major market and cyclical fluctuations. Since Elkem took over, however, Elkem PEA has been supplied with state-of-the-art technology. The plant has also been modernized and is now a modern and highly competitive operation. Close to 100 percent of the production is exported to the steel industry worldwide.

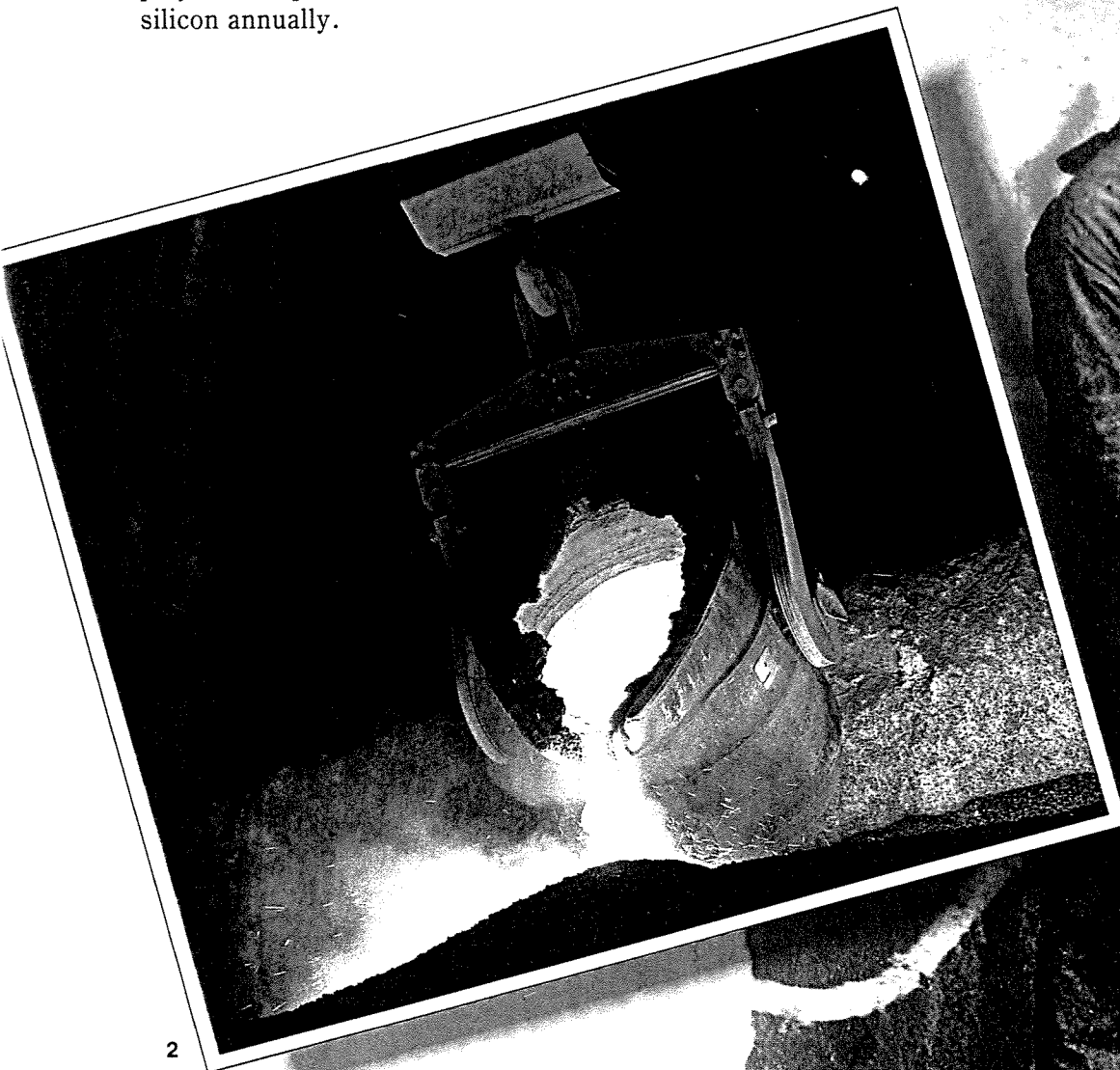

# A modern place to work

market. Our extensive training and educational programs in the mechanical, electrical/automation and electrochemical fields help insure top qualifications among our employees. Our training programs are conducted in close cooperation with other Elkem companies as well as with external contacts which include customers, suppliers, schools and universities.

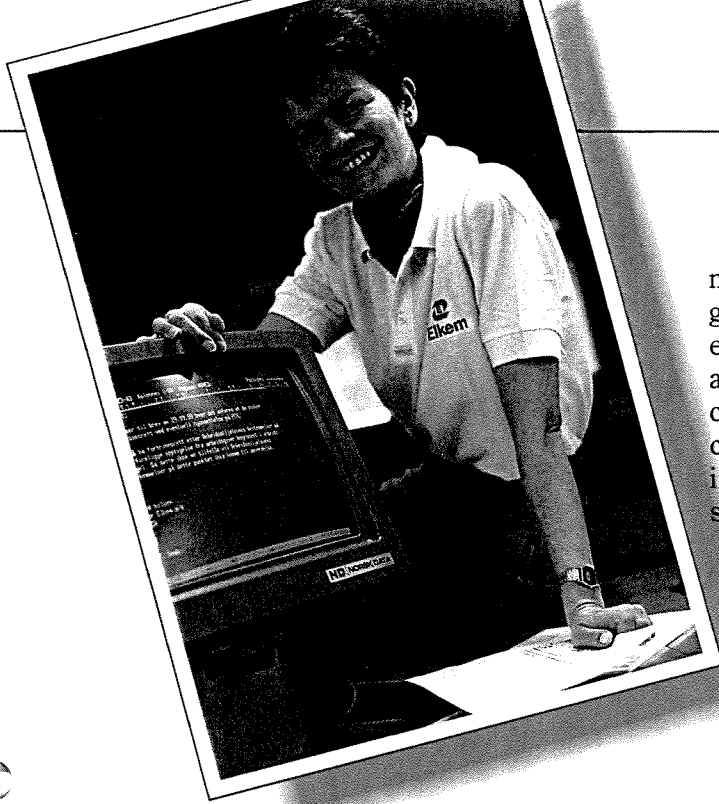

**E**lkem PEA, with its state-of-the-art smelting technology, is one of the most modern smelters in the world. The company's closed smelting furnaces and its refining plant are attached to an advanced treatment facility which handles and recycles valuable materials. Furnace operations, including raw material weighing, mixing and feeding are fully automated, as is the monitoring and control of the actual smelting process.

Highly skilled employees guarantee optimal utilization of our advanced smelting technology and help us maintain our leading position in the international

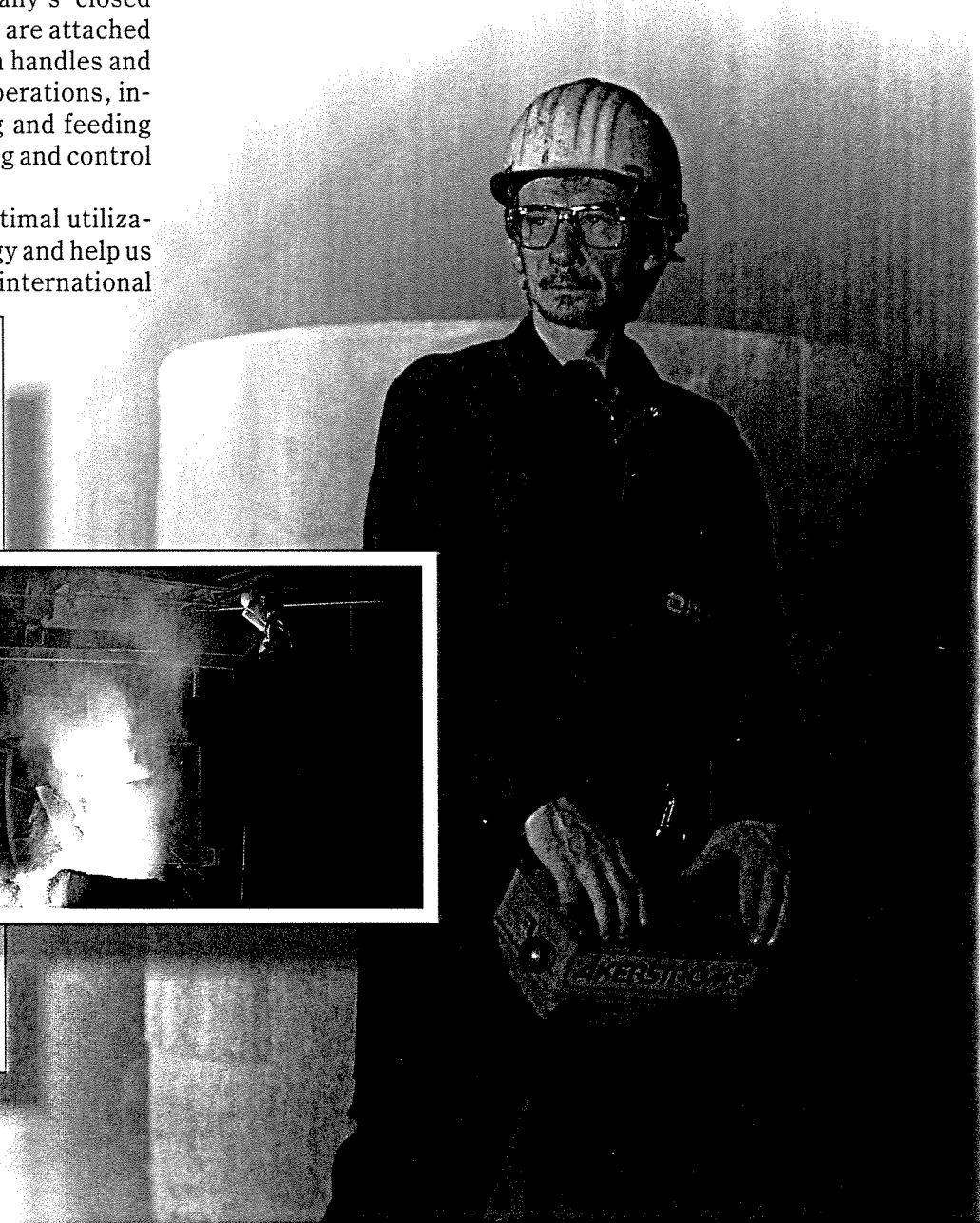
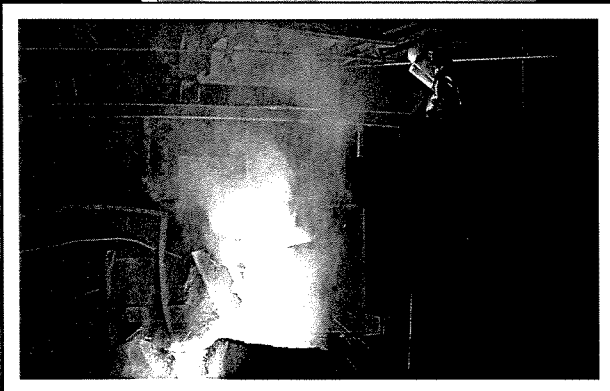
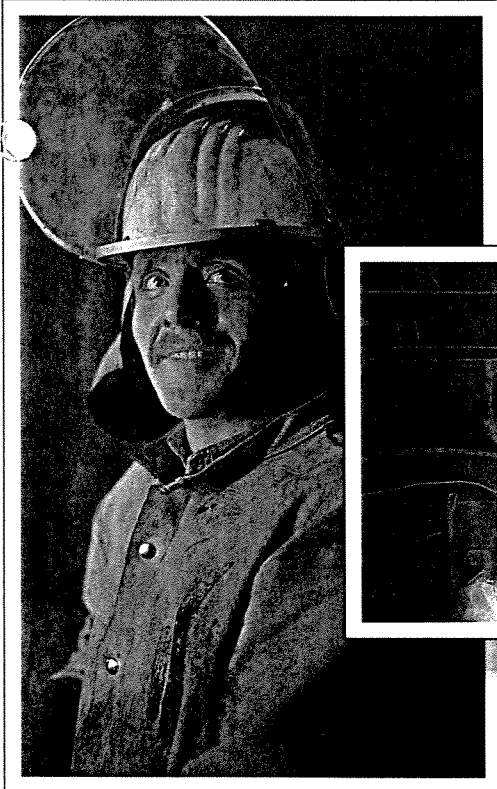

# A power-intensive industry

**E**lkem PEA is a power-intensive and value-added company. Steel mills in Europe, the Far East and America buy most of the smelter's manganese products. Although we may not realize it, we encounter products which contain manganese every day. The steel in tools and automobiles are examples of manganese steel. Although these products may be labeled "Made in Germany" or "Made in Japan", they are likely to contain manganese alloys from Elkem PEA in Porsgrunn.

Elkem PEA's three smelting furnaces produce high carbon ferromanganese (HC FeMn), medium carbon ferromanganese (MC FeMn) and silicomanganese (SiMn). All the furnaces are conventional reduction furnaces equipped with gas scrubbers to wet wash the furnace gases.

The raw materials - manganese ore, quartz and coke - are added to the furnace continuously. These serve as thermocouples between the electrodes and are heated to a liquid mass. The desired chemical reactions occur at temperatures ranging from 500 to 1500 degrees Celcius.

At high temperatures, the carbon in the coke reduces the manganese and ferric oxides and part of the silicium oxides, giving a liquid alloy. The slag is separated and tapped regularly.

In 1985, the company commissioned a new refining plant to produce ferromanganese with a carbon content of less than 1.5 percent. The process, called MOR (Manganese Oxygen Refining), transports the HC FeMn in liquid form to a reactor. Here, the carbon content is reduced to 1.5 percent or less by means of oxygen inoculates. The resulting product is called MC FeMn. Large quantities of Elkem PEA's CO gas is utilized as a source of heat in a nearby processing plant in order to avoid flaring the gas.

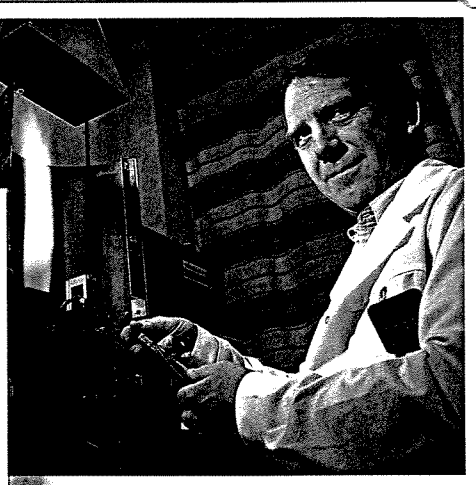
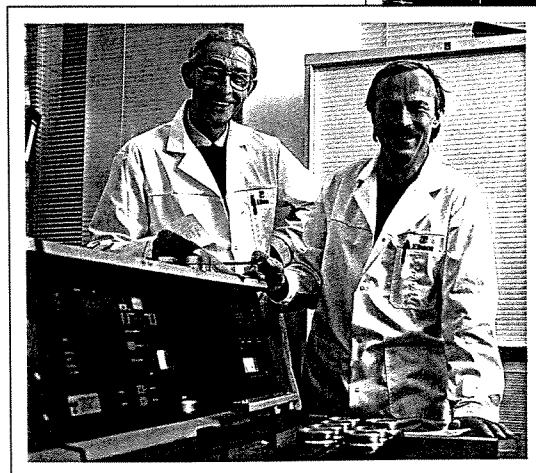
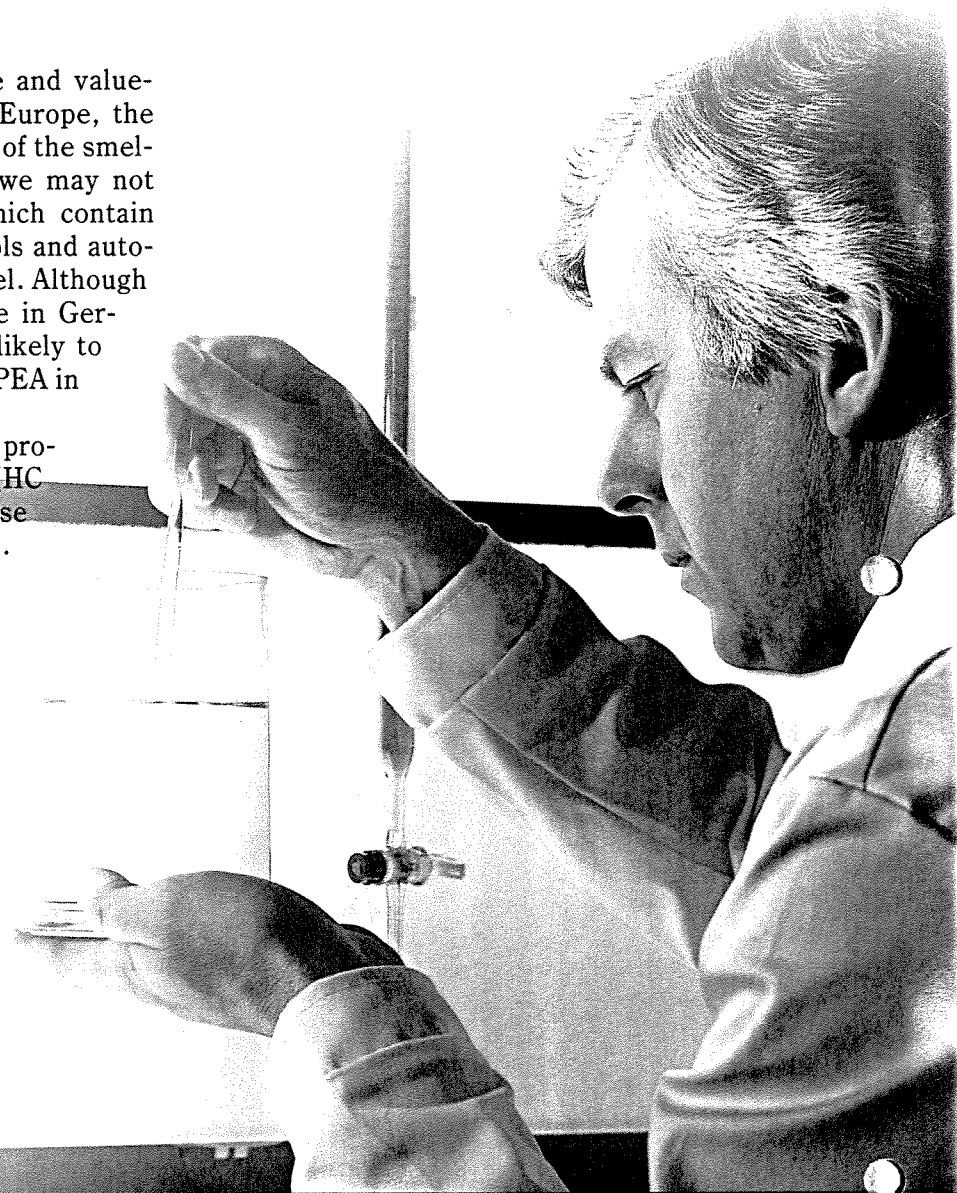

# Visions and strategy

**E**lkem PEA's goal is to be a leading, low-cost manufacturer of manganese alloys and to emerge as a reliable, vital, market-oriented company.

This vision, which is a positive, collective description of the future, will be the motivating force within the organization. The visions and strategy work will help to secure long-term survival and strengthen the company's long-term perspectives. The strategic plan will be the basis for goal-oriented management and establish an identity and provide motivation. The strategic planning will also help improve communication and understanding.

During the early to mid-90s Elkem PEA's visions and priorities include the following:

- Market orientation
- Quality
- Health, environment and safety
- Economic assumptions
- Industrial development
- Organization

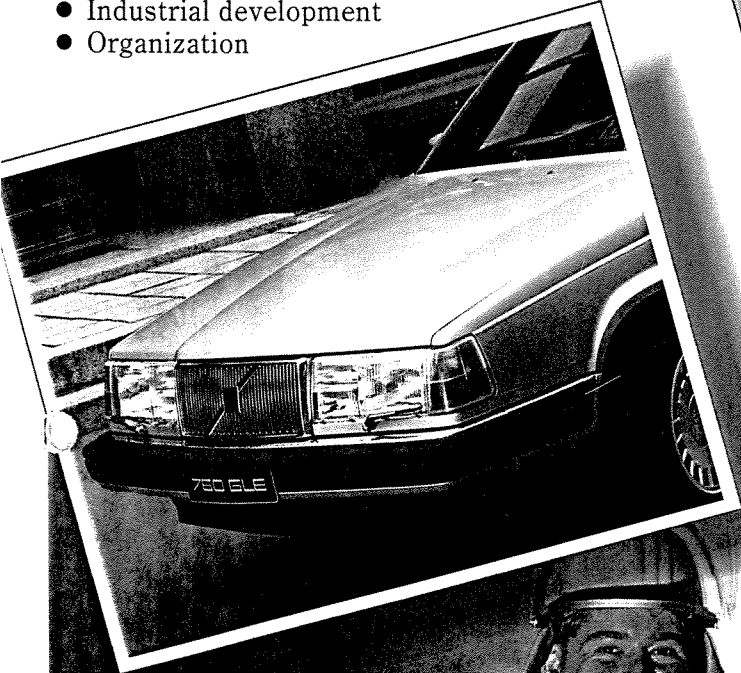

<b>Furnace 9</b> 25,000 tonnes 43,000 tonnes	SiMn HC FeMn (alternative)		
<b>Furnace 10</b> 55,000 tonnes	SiMn		
<b>Furnace 11</b> 100,000 tonnes	FeMn		
<b>Manganese Oxygen Refining (MOR)</b> 45,000 tonnes	MC FeMn		
<b>Product Analysis</b> Typical analysis of PEA's products			
Mn %	76-78	SiMn	78-83
Fe %	14-17	HC FeMn	65-73
Si %	0.1-0.5	MC FeMn	10-15
C %	6.8-7.0	SiMn	17-20
		FeMn	1.0-1.5
		MC FeMn	0.5-1.0
		MC FeMn	0.5-1.5
<b>Chemical Description</b>		<ul style="list-style-type: none"> <li>- Manganese</li> <li>- High Carbon Ferromanganese</li> <li>- Silicon</li> <li>- Medium Carbon Ferromanganese</li> <li>- Silicomanganese</li> <li>- Ferromanganese</li> <li>- Carbon</li> <li>- Oxygen</li> </ul>	
Mn			
HC FeMn			
Si			
MC FeMn			
SiMn			
FeMn			
C			
O			



# Elkem PEA

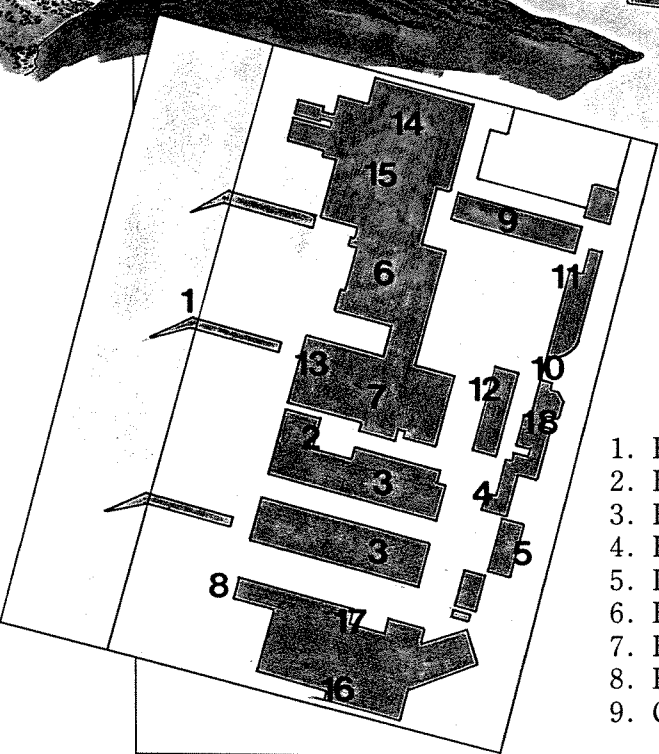
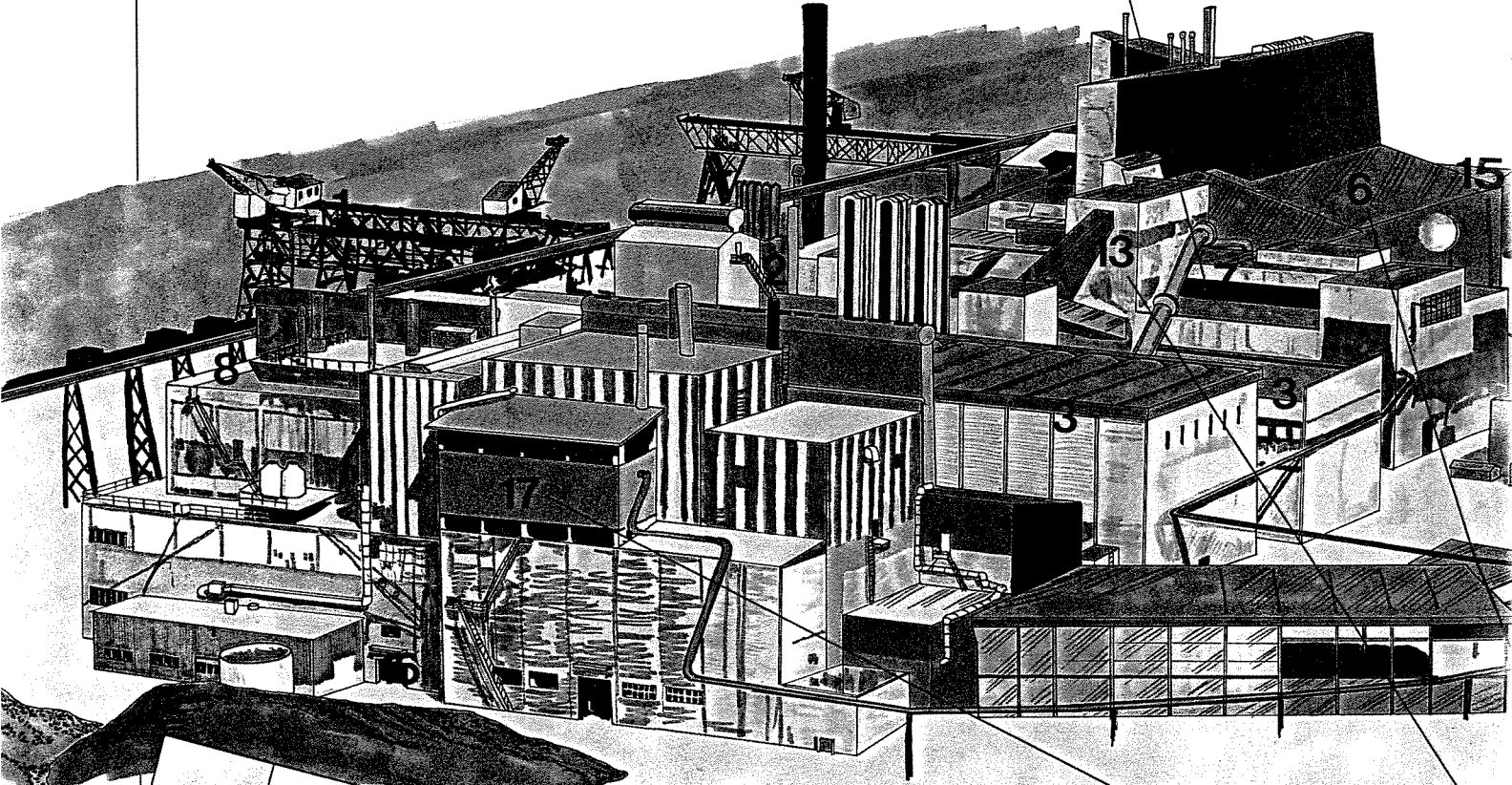
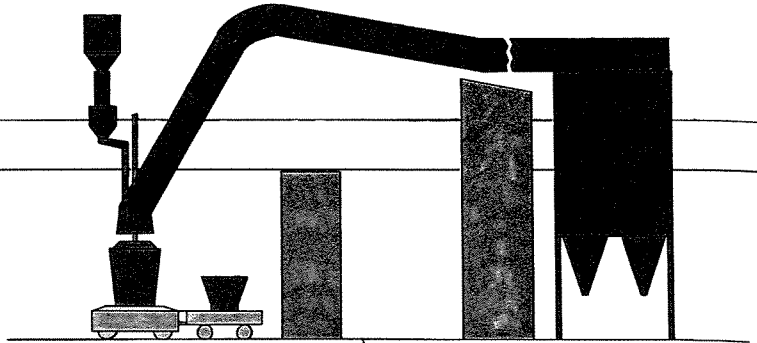

- 1. Port
- 2. Bag house
- 3. Raw material storage
- 4. Electrical maintenance
- 5. Laboratory
- 6. Furnace building I
- 7. Refining plant
- 8. Refractory department
- 9. Canteen
- 10. Main gate
- 11. Mecanical workshop
- 12. Health and welfare department
- 13. Furnace building II
- 14. Finished products department
- 15. Crushing and screening plant
- 16. Water purification plant
- 17. Furnace building III
- 18. Office/Administration

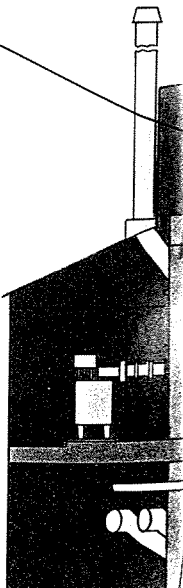

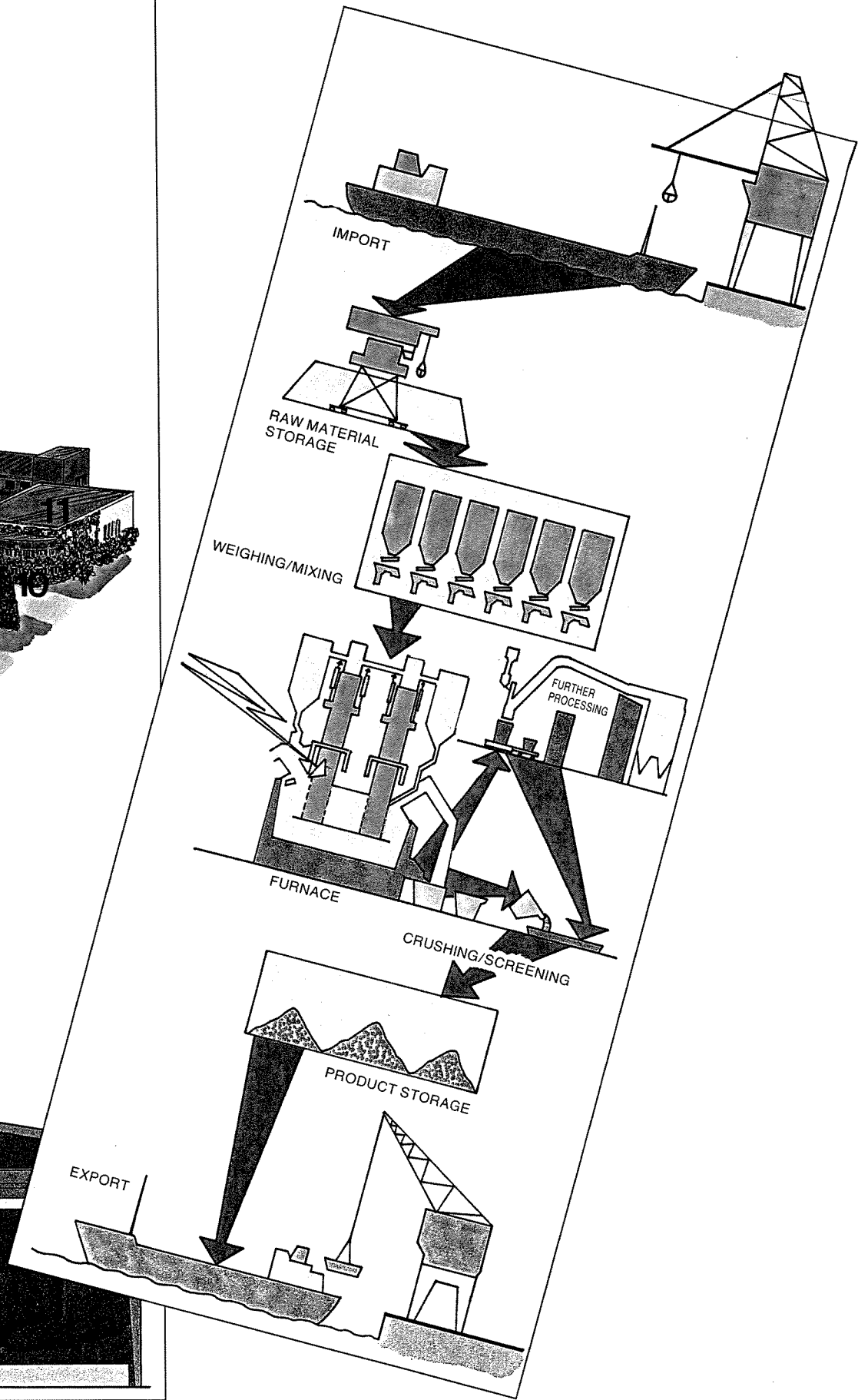
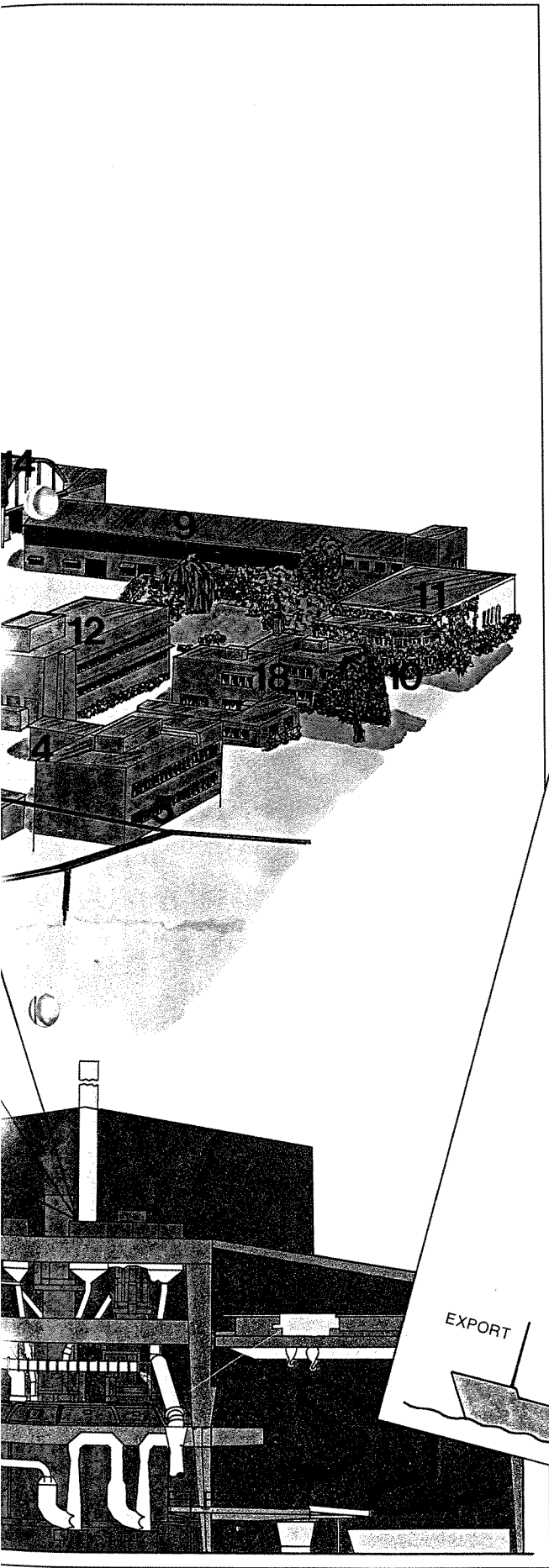



# Working environment

**W**e work hard to maintain a safe working environment at Elkem PEA. Preventing accidents, personal injuries and damage to the environment represent important goals. We also strive to fulfill all statutory requirements relating to the internal and external environment.

In addition, we have several cooperative bodies which initiate environmental and safety measures. We are mapping risk factors and measuring various aspects of the working environment in order to ensure optimal conditions. All materials and chemicals used at Elkem PEA are subject to declaration by the suppliers and all departments have individual material registers.

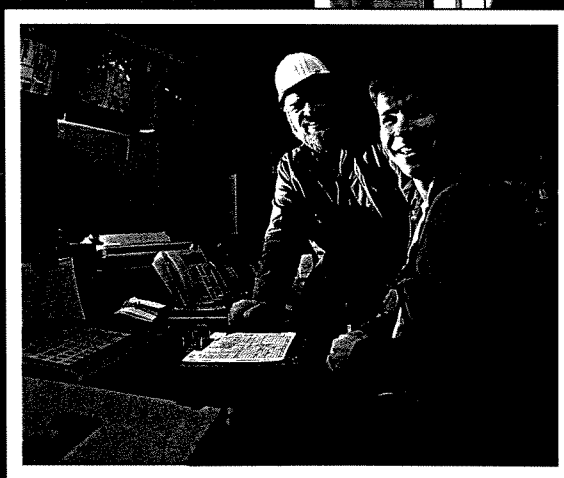

# Environmental protection

**E**nvironmental protection has top priority at Elkem PEA. We have major investments in internal and external environmental measures in recent years. From 1986 to 1989, we spent nearly NOK 60 million on a range of environmental measures.

1989 was Elkem PEA's greatest environmental year ever. We invested NOK 25 million in the environment - NOK 11 million on external measures and NOK 14 million on internal improvements. Major amounts were also spent on refurbishing production equipment. These investments will significantly improve Elkem PEA's competitive strength in the 1990s.

We have already begun to see results. Advanced cleaning equipment currently handles 99 percent of the dust from the closed furnaces. In addition, the PAH emissions (Polycyclic Aromatic Hydrocarbons) to the water have been reduced by 90 percent. Elkem PEA is well on its way to becoming a "clean" company, with emission levels well below required limits. The Norwegian authorities have indicated that future emission standards will become even more rigid.

Therefore, future investments will focus on achieving cleaner air and will include new plants to handle the remaining dust emissions connected with tapping the furnaces and reactors and from material handling.

Our parent company, Elkem, is constantly developing new environmental technology which will benefit our company as well as the international community.

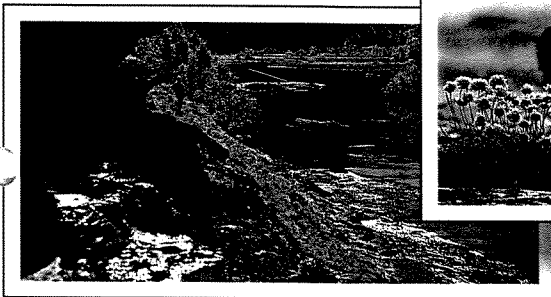
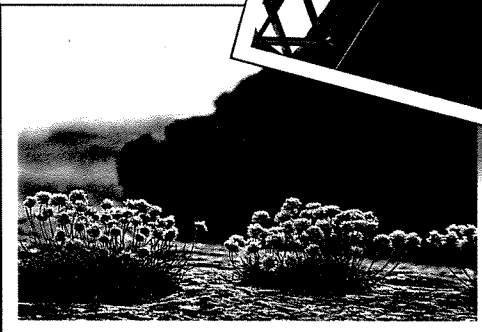

# Sport and recreation

**E**lkem PEA has made a significant contribution to Elkem's sports club for many years and has also provided various recreational facilities for its employees. The company has both seaside and mountain cabins which may be used by its employees.

## Company sports club

Elkem PEA's employees as well as their families may participate in the company's sports activities. The sports club has its own board, and membership is free.

Company sports activities have become a natural and necessary part of the company culture. They bring people together and create positive contact between the company and the employees' families. These activities also serve to improve contact between employees who work shifts or at different plant locations with little opportunity for social contact.

## Elkem PEA's cabins

Elkem PEA has five cabins in the mountains and five cabins at Mørje fjord. The mountain cabins are located at Gautefallheia, Vågsli and at Rauland. Four of the cabins are about 960 meters above sea level. The cabins are available to all full-time employees as well as to retirees.

The mountain cabin "Arabu" in Rauland which is the largest, comfortably houses 21 people. It is used for courses and seminars run by the personnel department, but may also be used by the employees when courses are not in session.

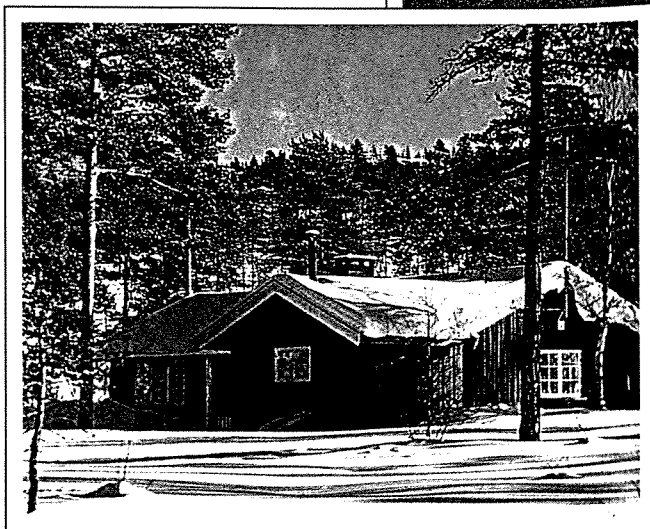

# Porsgrunn Municipality

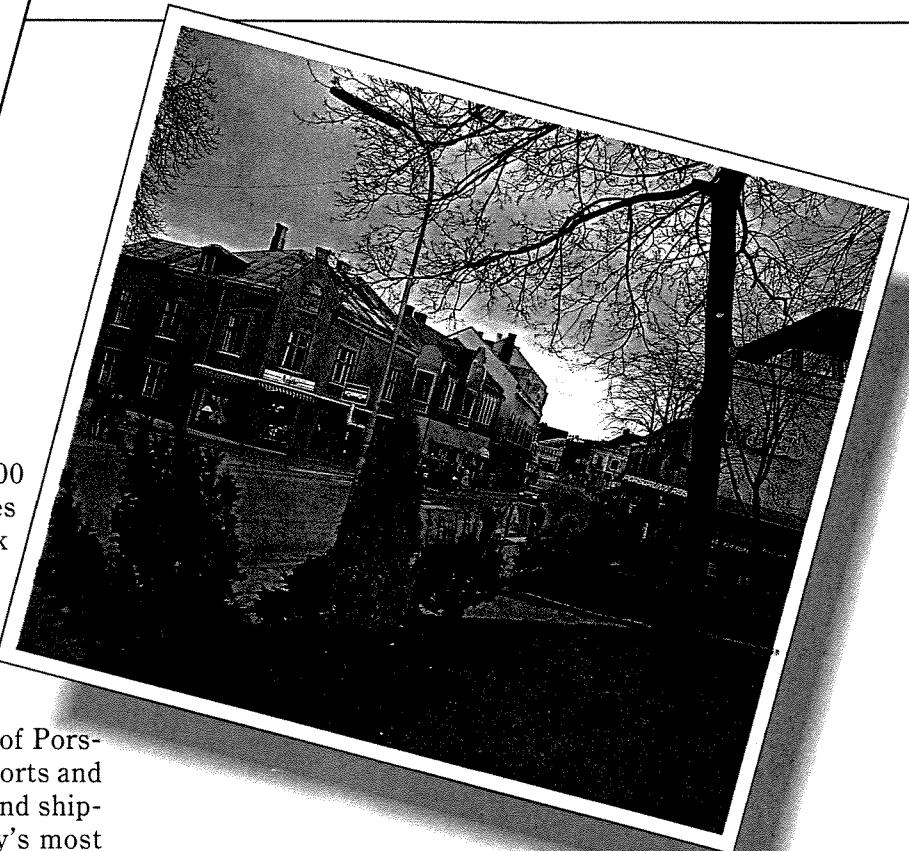

**P**orsgrunn Municipality has 32,000 inhabitants and comprises the cities of Porsgrunn (12,000) and Brevik (2,500) as well as the built-up areas of Eidanger, Heistad, Herøya, Langgangen and Stridsklev. The outer limits of the municipality comprise about 100 large and small islands with a total shoreline of 127 km.

Just over one hundred years ago, the city of Porsgrunn was one of Norway's largest sailing ports and was nurtured by timber trading, shipping and ship-building. Today, the area is one of Norway's most industrialized municipalities.

Porsgrunds Porselænsfabrikk, established in 1895, has 350 employees, and is Norway's only porcelain factory. There are a number of other medium-sized companies in the area.

The municipality has a range of educational offerings, including technical colleges, engineering colleges, graduate engineering studies, computer

training and the research center TELTEK which comprises technical consulting and development.

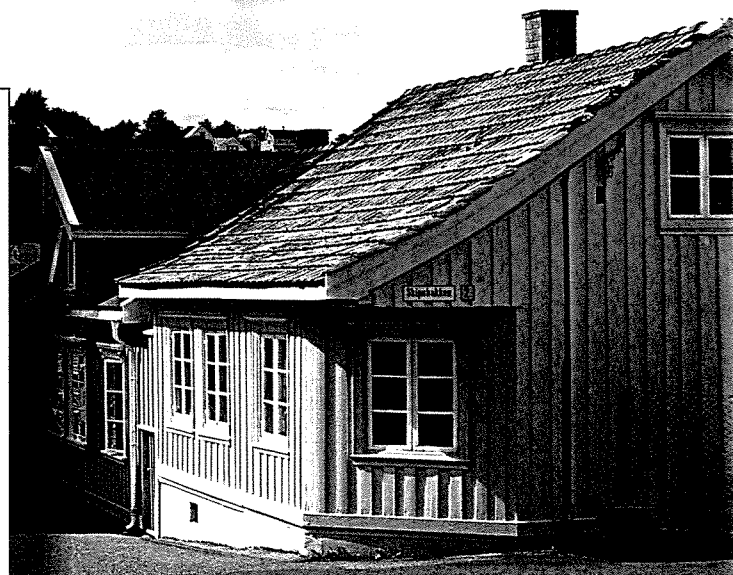
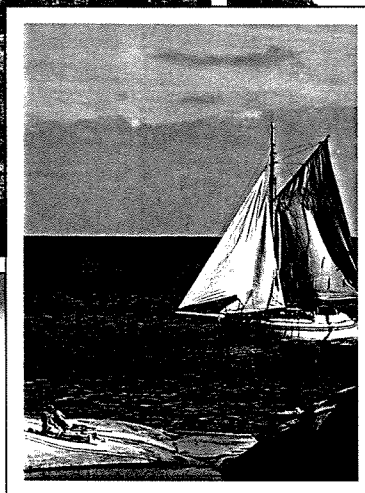
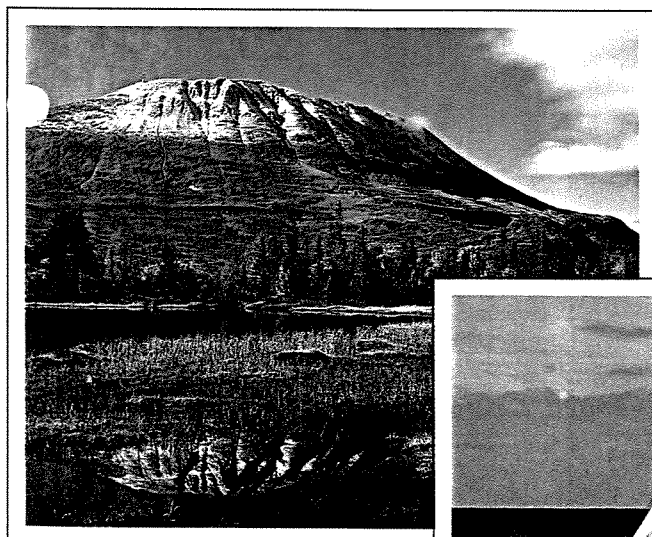

Elkem PEA is a subsidiary of Elkem a/s which is a leader in supplying metals, alloys and specialty materials to the world's steel, foundry and aluminium industries. In addition, Elkem is building a base in high purity metals, advanced ceramics and environmental technology. Although best known today as the world's leading producer of ferroalloys and silicon metal, and a major supplier of aluminium - Elkem provides the products and services necessary to meet customer expectations in a wide range of markets:

- From specialty inoculants and ferroalloys for the steel and foundry industries to additives for dramatically increasing the strength of concrete.
- From high purity silicon metal for the aluminium, electronics and silicone industries to aluminium sheets for everything from car parts to plates for the printing industry.
- And from electrodes for high temperature smelting to innovative systems for recovering valuable by-products while cleaning up pollution and hazardous waste.

With 7,500 employees worldwide, Elkem operates 24 production plants in Europe and North and South America, as well as a global network of sales offices.

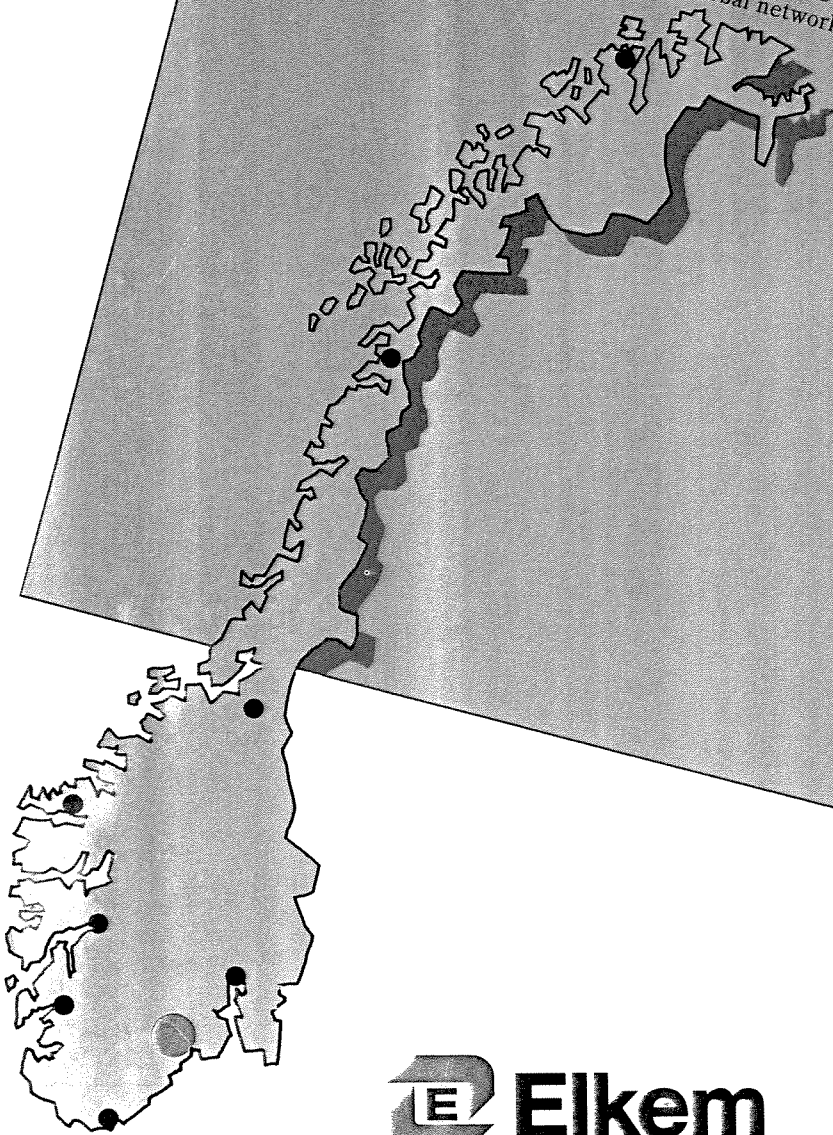

Elkem PEA  
P.O.Box 82  
Rolighetsveien 11-17  
N-3901 Porsgrunn  
Norway  
Telephone: +47 3 56 18 00  
Telefax: +47 3 55 36 10  
Telex: 21509

## **Appendix 8: Information about Ertelien Nickel Mine**

O-93083

Kartlegging av  
forurensningstransport fra  
Ertelien Nikkelgruve,  
Ringerike



## Sammendrag

I perioden juli 1993 - juni 1994 har NIVA gjennomført undersøkelser av forurensningstransport fra Ertelien Nikkelgruve i Ringerike kommune.

Undersøkelsen omfattet regelmessig måling av vannføring på to punkter i området. Dessuten er det ved en anledning tatt prøver fra veltet, og det er tatt en sedimentprøve fra innsjøen Åsterudtjern, som er en av nærresipientene for gruveavrenningen.

Gruveavfallets sammensetning fører til at de viktigste forurensningskomponentene fra Ertelien Nikkelgruve er nikkel og kopper. Total transport fra området av disse metallene er beregnet til ca. 730 kg nikkel og 180 kg kopper pr. år.

Hovedkildene for forurensning er veltene, og spesielt veltet som ligger lengst i øst, ved veien langs Tjernslibekken, synes å inneholde betydelige mengder kopper og nikkel. Med dagens transport er nikkelinholdet i denne veltet tilstrekkelig for ca. 90 år, mens koppertransporten kan fortsette i flere hundre år.

Åsterudtjern er i dag fisketom. Vann fra denne innsjøen benyttes til jordbruksvanning. Dette vannet er etter SFTs klassifisering av miljøkvalitet i ferskvann meget dårlig egnet for dette formålet.



Tabell 1 Geografiske data om beliggenheten av Ertelien Nikkelgruve.  
Karthensvisningene gjelder Statens Kartverks serie M711

Fylke	Kommune	Kartblad	Rute
Buskerud	Ringerike	Hønefoss 1815 III	32V NM 57/58 59

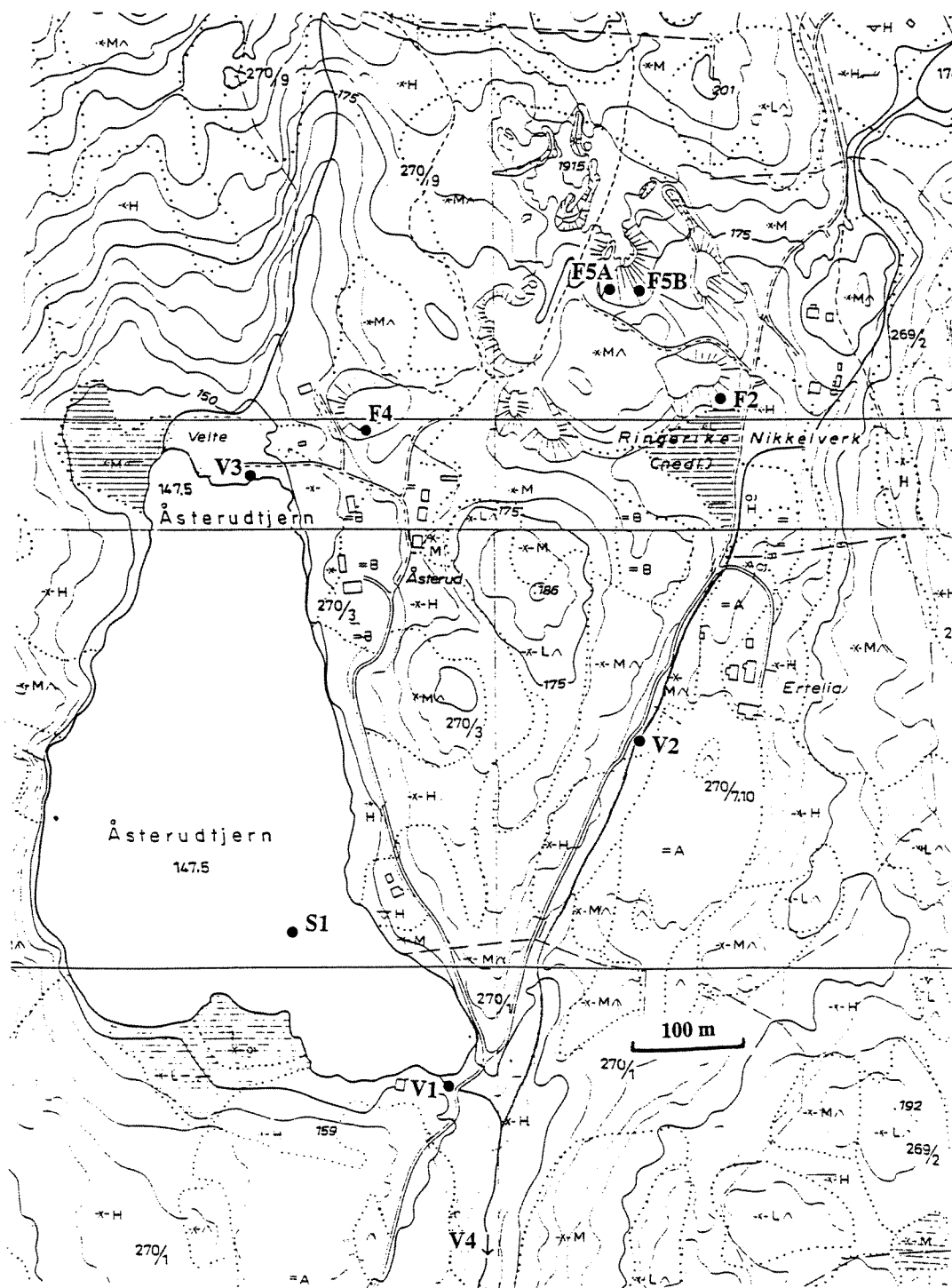

Figur 1 Kartskisse over området ved Ertelien Nikkelgruve.  
Prøvepunkter for vann (V), gruveavfall (F) og sediment (S) er inntegnet

Tabell 3 Analyseresultater for prøver fra velter tatt 25. august 1993 Ringerike nikkelverk, Ertelien gruve.

Velte nr.: 2 : Lengst i øst ved vei langs Tjernslibekken, Velte nr.: 4 : I nordøstre ende av Åsterudtjern, Velte nr.: 5 A : Øst for hovedgruve nær veien opp til dagbruddet., Velte nr.: 5 B : Litt lengre øst enn nr.: 5 A

Prøve	pH	Konduktivitet mS/m	Svovel %	Jern %	Kopper g/kg	Sink g/kg	Nikkel g/kg
Velte nr.: 2							
Totalt			5.53	12.4	10.3	0.10	2.36
Vannløselig	3.15	176	0.29	0.03	0.28	0.01	0.23
Andel vannl. %			5.3	0.24	2.72	5.79	9.91
Velte nr.: 4							
Totalt			2.65	10.2	1.58	0.04	0.24
Vannløselig	2.49	298	0.52	0.19	0.07	0.00	0.01
Andel vannl. %			19.6	1.9	4.36	7.85	4.49
Velte nr.: 5 A							
Totalt			0.88	3.0	0.52	0.07	0.36
Vannløselig	4.79	2.19	0.29	0.0	0.002	0.00	0.03
Andel vannl. %			33	0	0.39	3.76	7.16
Velte nr.: 5 B							
Totalt			0.53	2.7	0.37	0.06	0.32
Vannløselig	7.00	19.3	0.024	0.0	0.0	0.0	0.00
Andel vannl. %			4.5	0	0.0	0.0	0.50

Tabell 4 Innhold av svovel og tungmetaller i veltene ved Ertelien Nikkelgruve  
Tabellen inneholder totalt og vannløselig innhold av komponenter.

Velte		Svovel tonn	Jern tonn	Kopper tonn	Sink tonn	Nikkel tonn
2	Totalt	1183	2805	233	2.15	53
	Vannløselig	66	6.9	6.3	0.12	5.3
4	Totalt	192	739	11.5	0.30	1.73
	Vannløselig	38	14	0.50	0.02	0.08
5	Totalt	153	617	9.5	1.36	7.4
	Vannløselig	5.7	0.03	0.02	0.03	0.29

## 4. Resipientforhold

Avrenningen fra Ertelien-området går til to forskjellige primærresipienter. Den østlige delen av området, antakelig inkludert gruvevannet fra gruve 2, renner til Tjernslibekken, mens de vestlige gruvene (Åsterud 1 - 3) og antakelig gruve 3 drenerer til bekken som renner inn i nordenden av Åsterudtjern.

Bekken fra utløpet av Åsterudtjern og Tjernslibekken renner sammen umiddelbart etter utløpet fra innsjøen. Like nedenfor samløpet renner bekken inn i et rør som drenerer et større jordbruksområde. Ca. 1 km lengre sør går bekken i en kulvert under vegen. Ytterligere 1 km lengre nede renner bekken inn i Henoa, som er en av tilløpselvene til Tyrifjorden.

## 7. Transportberegninger

Som grunnlag for transportberegningene er kjemiske analysedata og de målte vannføringene ved prøvetakingen benyttet. Transportverdien er beregnet som tidsveiede middelverdier av de momentante transportverdiene som kan beregnes slik i perioden 1. juli 1993 til 30. juni 1994.

I tabell 10 er disse middelverdiene fra de ulike målepunktene listet. Det er alltid en betydelig usikkerhet i slike transportberegninger. Uten at det kan kvantifiseres er antakelig de listede transportverdiene noe for lave. Først og fremst gjelder dette Tjernslibekken og i utløpet av Åsterudtjern. Ved dette målepunktet har vannføringen til tider vært null, bl.a. på grunn av pumping til jordbruksvanning. Den samlede avrenningen fra området er derfor litt høyere enn den registrerte. Samtidig vil forholdsvis lite av de metallene som spres gjennom vanning (irrigasjon) av jordbruksarealer nå det nedenforliggende vassdraget.

Fordi undersøkelsen har strukket seg over et helt år, og regelmessige vannføringsmålinger på to punkter inngikk i undersøkelsen, er resultatene forholdsvis pålitelige, når vi ser bort fra den naturlige variasjonen som alltid skjer fra år til år og den usikkerheten som følger med at prøvetakingsfrekvensen tross alt er lav.

Tabell 10 Transport av tungmetaller ved målestasjonene ved Ertelien Nikkelgruve

	Sulfat tonn/år	Alu- minium tonn/år	Jern kg/år	Kopper kg/år	Sink kg/år	Nikkel kg/år
Tjernslibekken	23	1.3	217	153	19.6	595
Utløp Åsterudtjern	14	0.030	104	30	-	137
Sum fra gruveområdet	37	1.3	321	183	19.6	732
Samlet avløp	25	1.1	214	147	-	447
Samlet avl., korr. vannf.	30	1.3	257	176	-	536

I tabell 10 er det også angitt transportverdier for samlet avrenning fra området. Samlet avløp representerer de verdiene som er beregnet ut fra summen av de registrerte vannføringene. Samlet avl. korr. vannf. representerer summen av målte vannføringer korrigeret for den økede vannføringen som skyldes et større nedbørfelt. Verdiene er beregnet direkte ut fra forholdet mellom de aktuelle arealene. Forskjellen mellom sum fra gruveområdet og den korrigerede verdien for samlet avrenning er ikke større enn det som må ventes ved en slik undersøkelse.

## 8. Konklusjoner

1. Forurensningstransporten fra Ertelien Nikkelgruve er målt i 1993/94. Resultatet av undersøkelsen sammenholdt med tidligere prøvetakinger tyder på at det ikke har vært påviselige endringer i løpet av de siste 10 - 15 år. Sedimentanalyser fra Åsterudtjern tyder på det samme, men det er mulig at nikkeltransporten etter hvert har avtatt noe. Det er nikkel og kopper som er de viktigste forurensningskomponentene og transporten av nikkel og kopper er beregnet til henholdsvis 730 og 180 kg pr. år.

## **Appendix 9: Information about Denofa og Lilleborg Fabrikker A/S**

# Edible Oils and Fats

# CONTENT

DENOFA 4

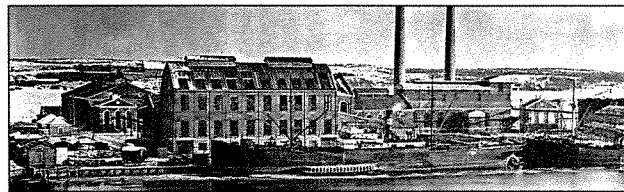

RAW MATERIALS 6

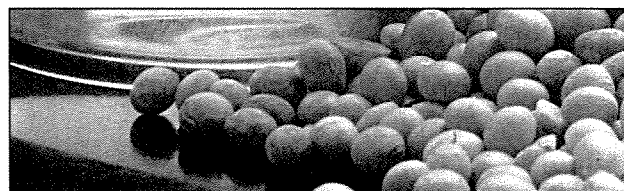

PRODUCTION 8



QUALITY 13

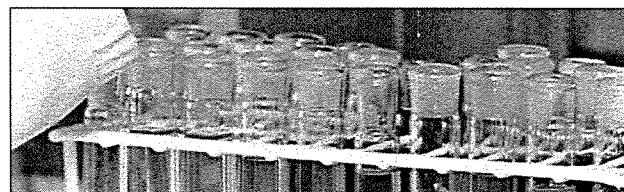

RESEARCH AND DEVELOPMENT 13

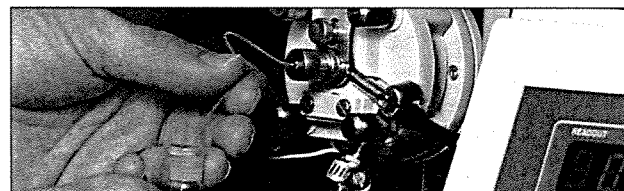

DISTRIBUTION 14

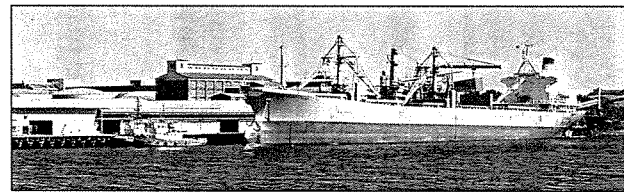

PRODUCTS AND MARKETS 16

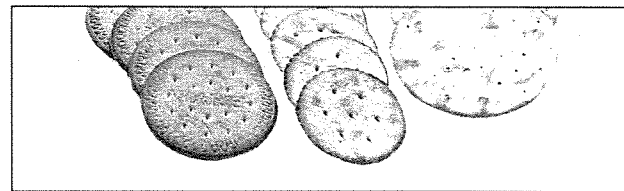

A/S DENOFA OG LILLEBORG FABRIKER 18



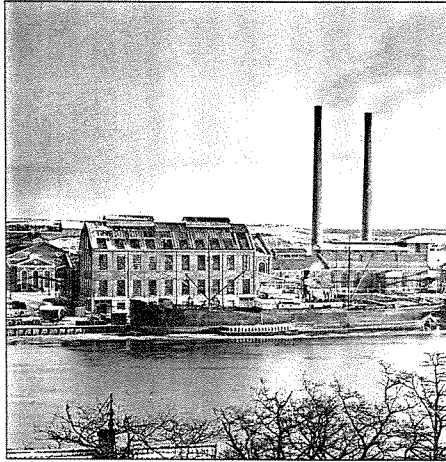

# DENOFA

De Nordiske Fabriker A/S (De-No-Fa) was established in 1912, based on the exploitation of a German patent for converting whale-oil into pure, white edible fat. The sea provided at that time resources which seemed to be inexhaustible. This, together with Norway's leading position in whaling, gave favourable conditions for the company.

At Denofa's plant in Fredrikstad, more than 150.000 metric tons of edible oils and fats are manufactured each year from crude vegetable and marine oils. Today, Denofa is the sole Norwegian producer of oils and fats for the food industry. More than 40 % of the total tonnage is exported.

At the start of this century, when industrially produced edible fats became a major commodity, Denofa was one of the pioneers. Today, Denofa is the world's leading exporter of marine oils and fats.

From the very start, the company has undergone continual changes, both in production processes, product ranges and markets. Due to its long experience and untiring efforts towards technological and product improvements, Denofa is fully equipped to meet tomorrow's needs and the requirements in an ever changing world.

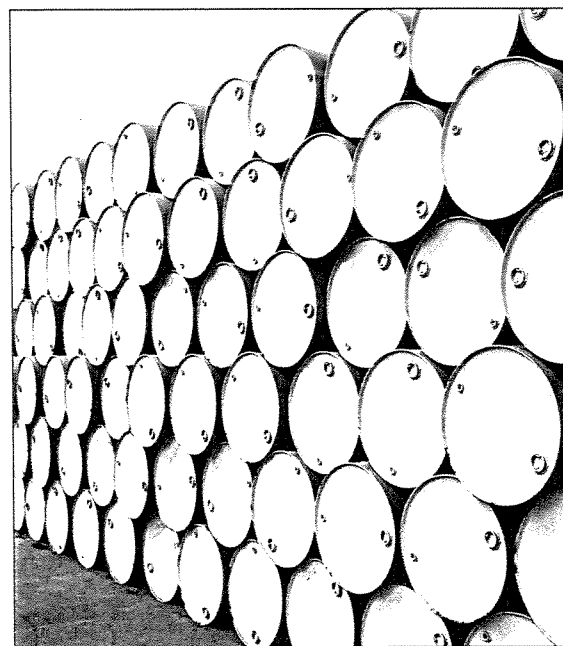
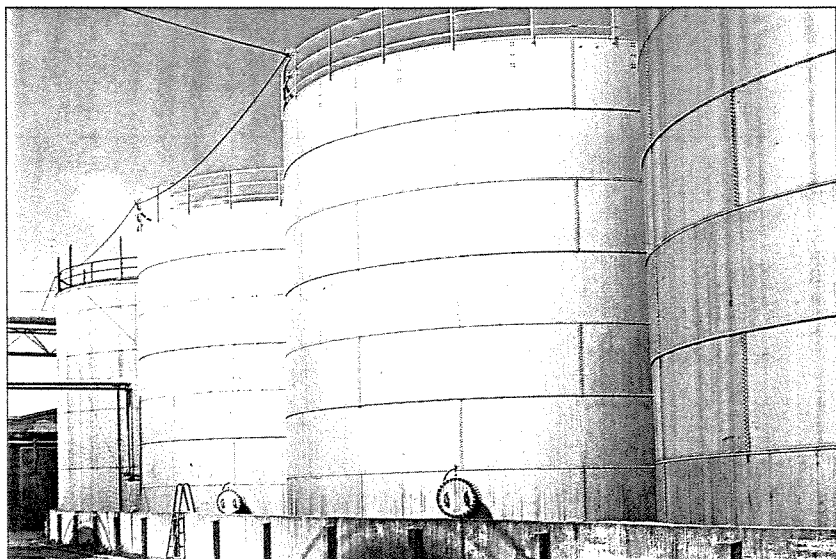
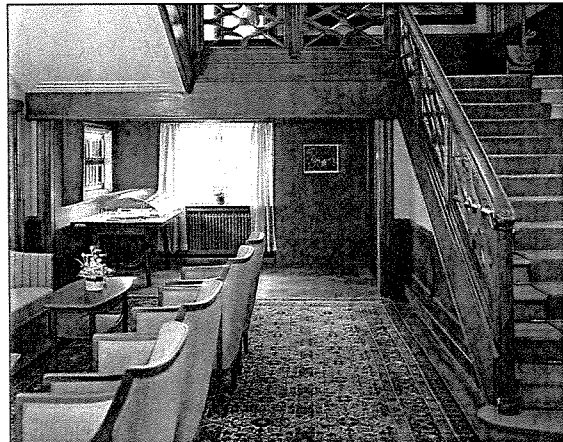
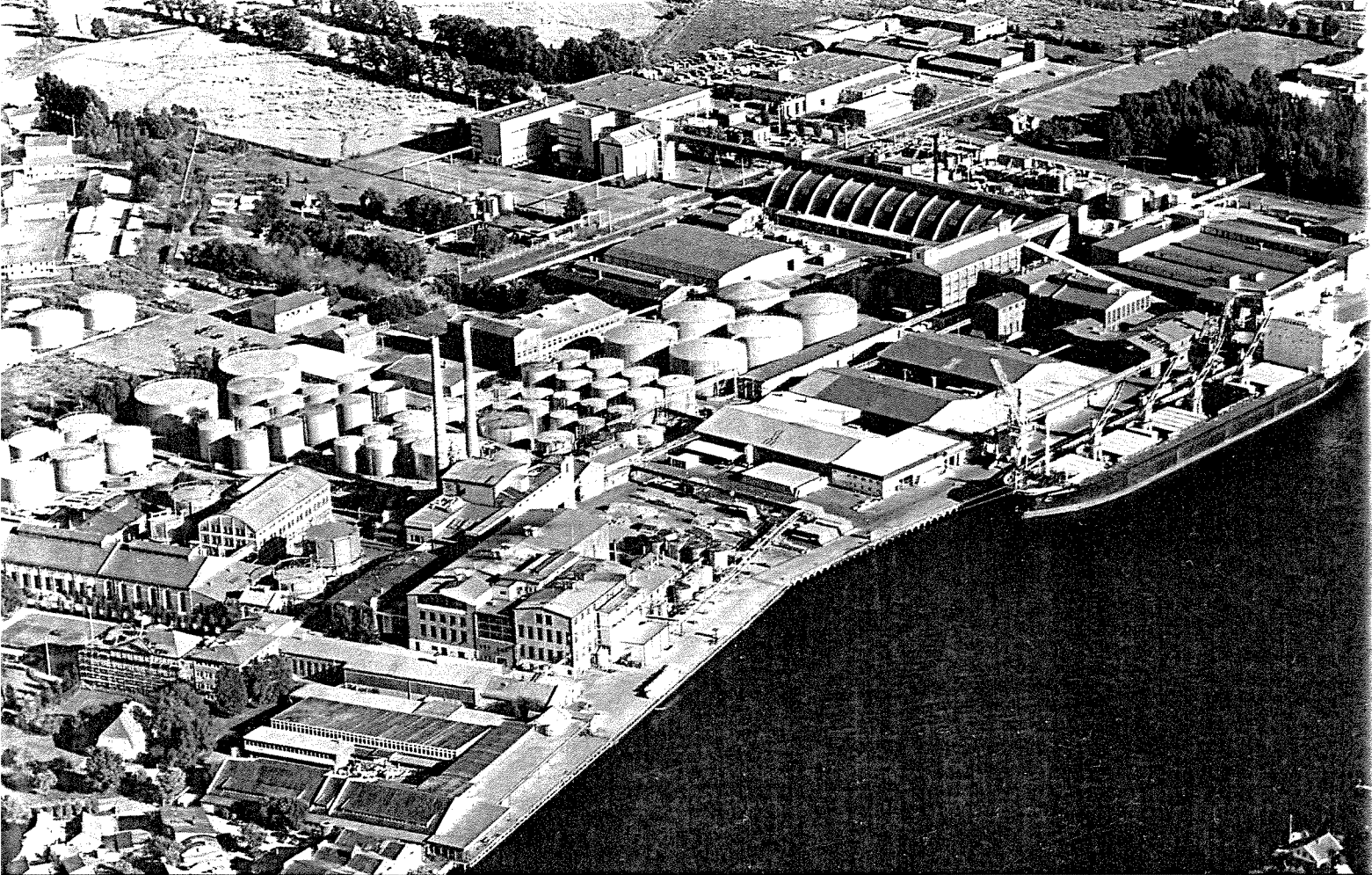



# RAW MATERIALS

Denofa's production of oils and fats is based on first class raw materials. Years of experience have taught us where and how to obtain the best.

Denofa is selecting the crude marine oils from producers operating in the seas around Norway, Iceland, Japan and off the West Coast of South America.

Soybeans are mainly imported from the USA and South America.

Coconut oil and palm oil are imported from the Philippines and Malaysia.

All the raw materials are unique and are treated individually to preserve their high quality. Denofa's purchase policy is to buy optimal quantities which secure necessary storage and at the same time ensure a uniform quality in our products.

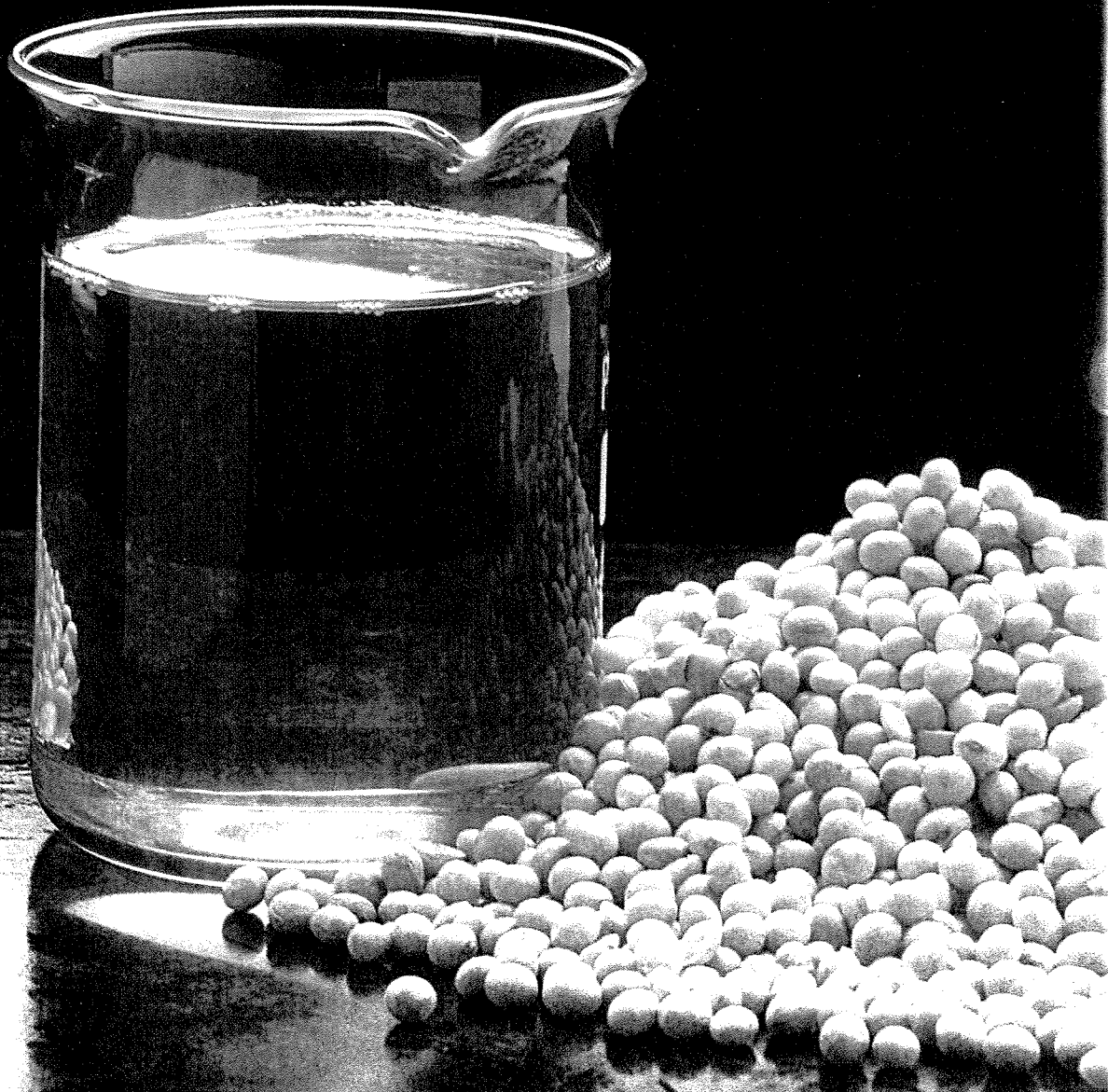



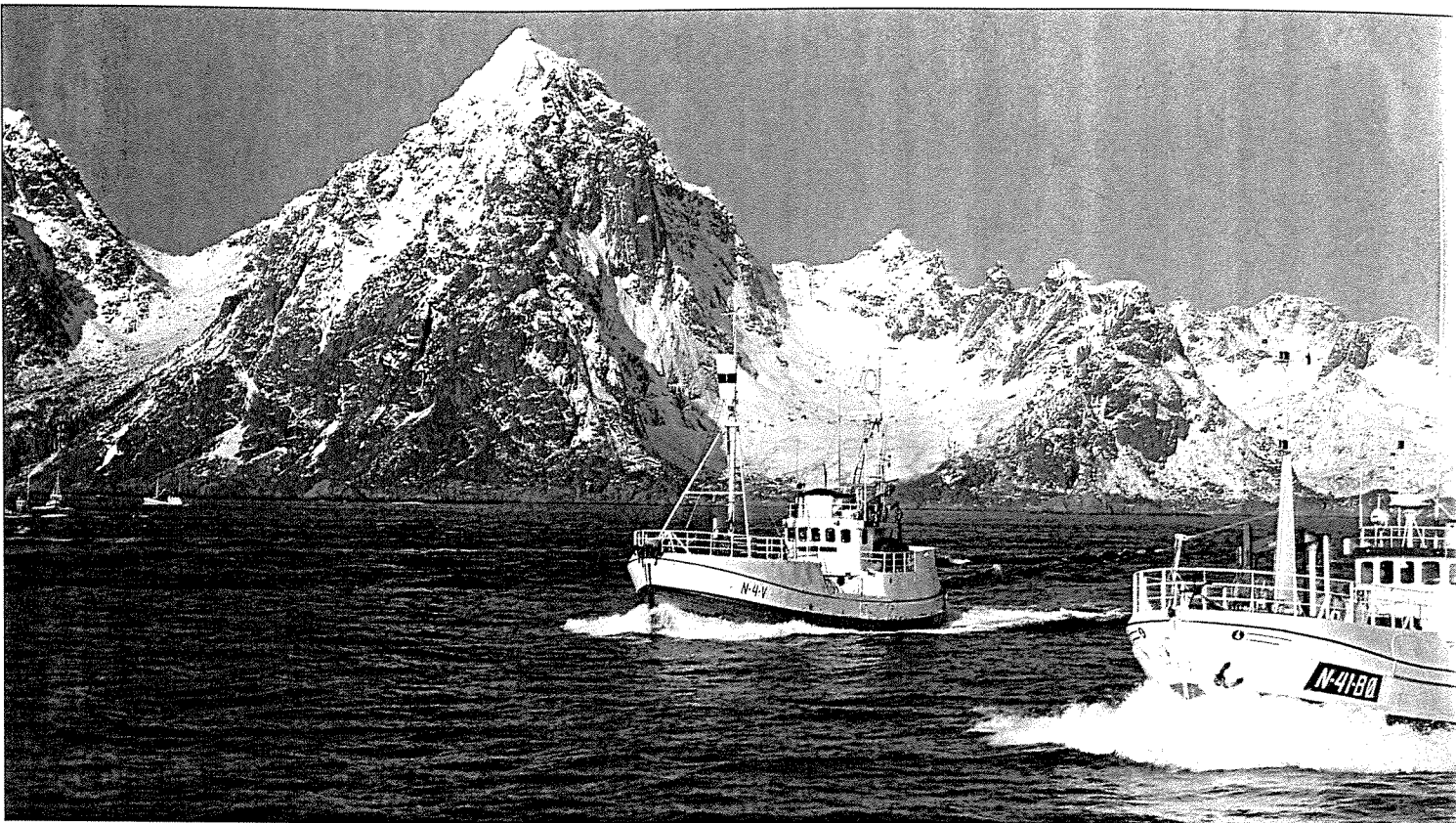

# PRODUCTION

At Denofa, big demands and challenges confront us daily. By extensive use of modern automatic and electronic process control, different raw materials are transformed into a wide range of products. By strict control of the various production lines and processes, products of the highest quality are obtained. Production takes place under the strictest requirements to hygiene, environment and safety.

pounds. The neutralization gives two products: neutral oil and acid oil. The neutral oil is treated with an active bleaching earth to remove pigments, oxidized components and other impurities, while the acid oil is sold for technical purposes.

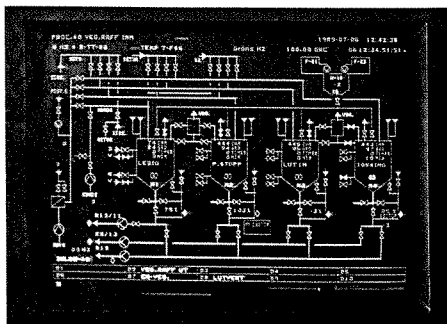

## HYDROGENATION

The neutralized, bleached oil is now ready for hydrogenation. With the help of a catalyst, hydrogen is added to some of the double bonds in the fatty acid chains. Through this process, the oil obtains a firm consistency and improved storage properties. The oil is converted into solid fat.

The hydrogen is produced by electrolysis of water in Denofa's own hydrogen factory.

## EXTRACTION

From large storage halls, the soybeans are conveyed to the extraction plant, where they are first pre-treated. More than 1.000 tons of soybeans are then converted, by solvent extraction, into oil and meal every 24 hours.

## POST—REFINING

The hydrogenated fat is again neutralized and filtered to remove traces of metals and to reduce the free fatty acid content.

## REFINING

In the refining process, free fatty acids and other impurities are removed from the crude oils. The first step is neutralization, which removes free fatty acids and organic phosphorous com-

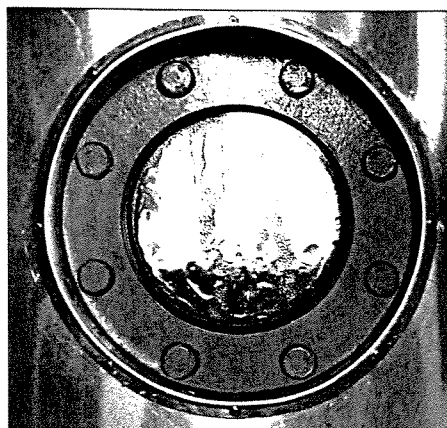

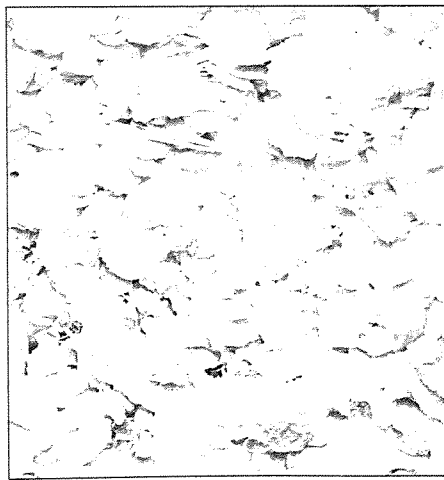
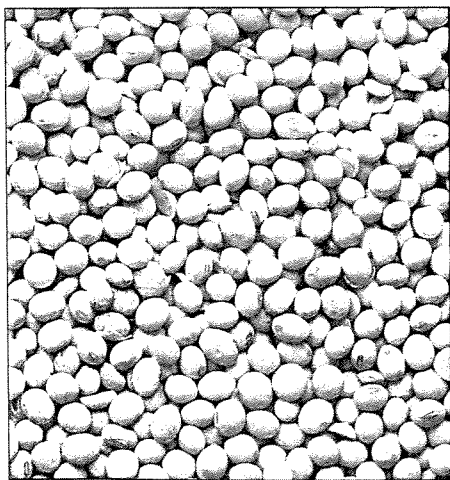
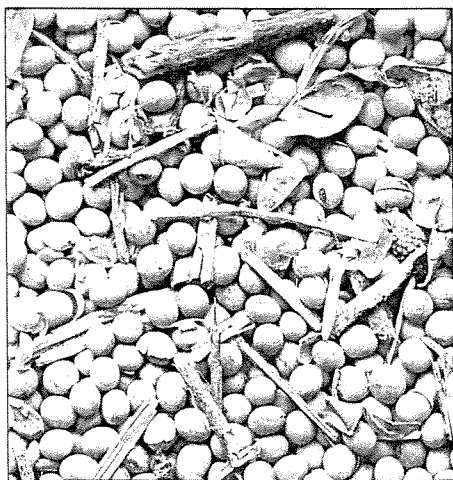
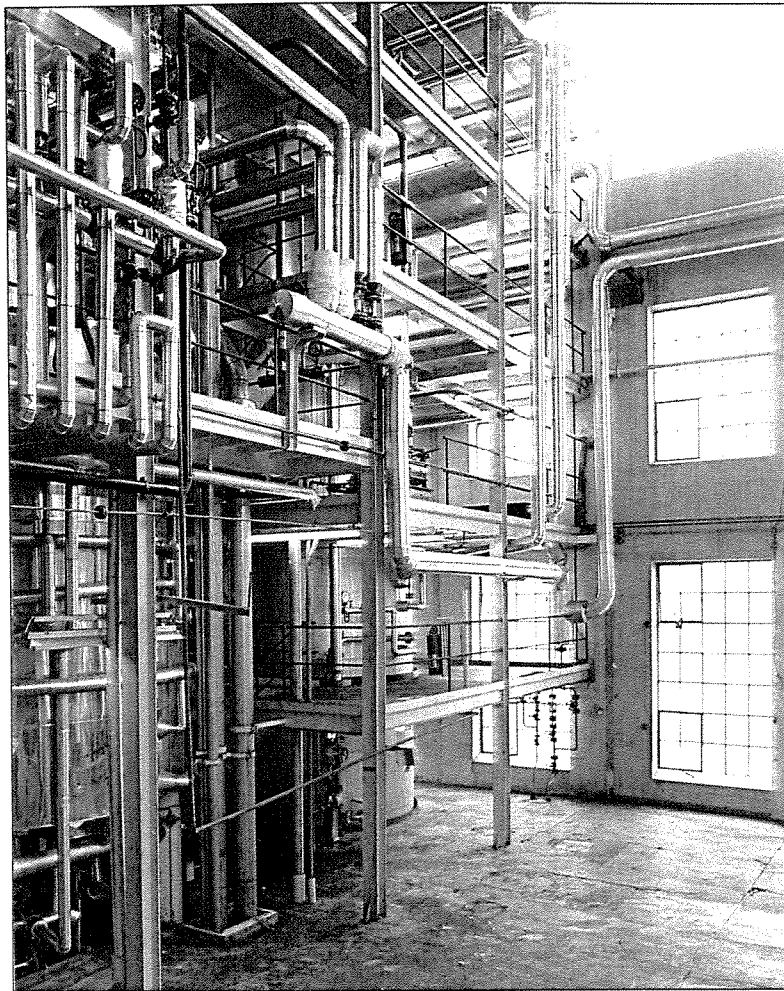
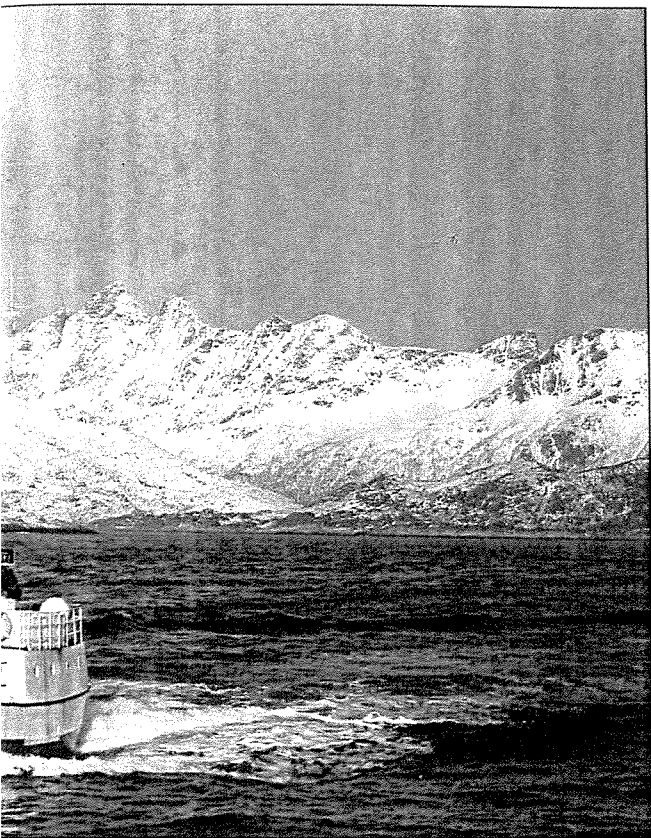

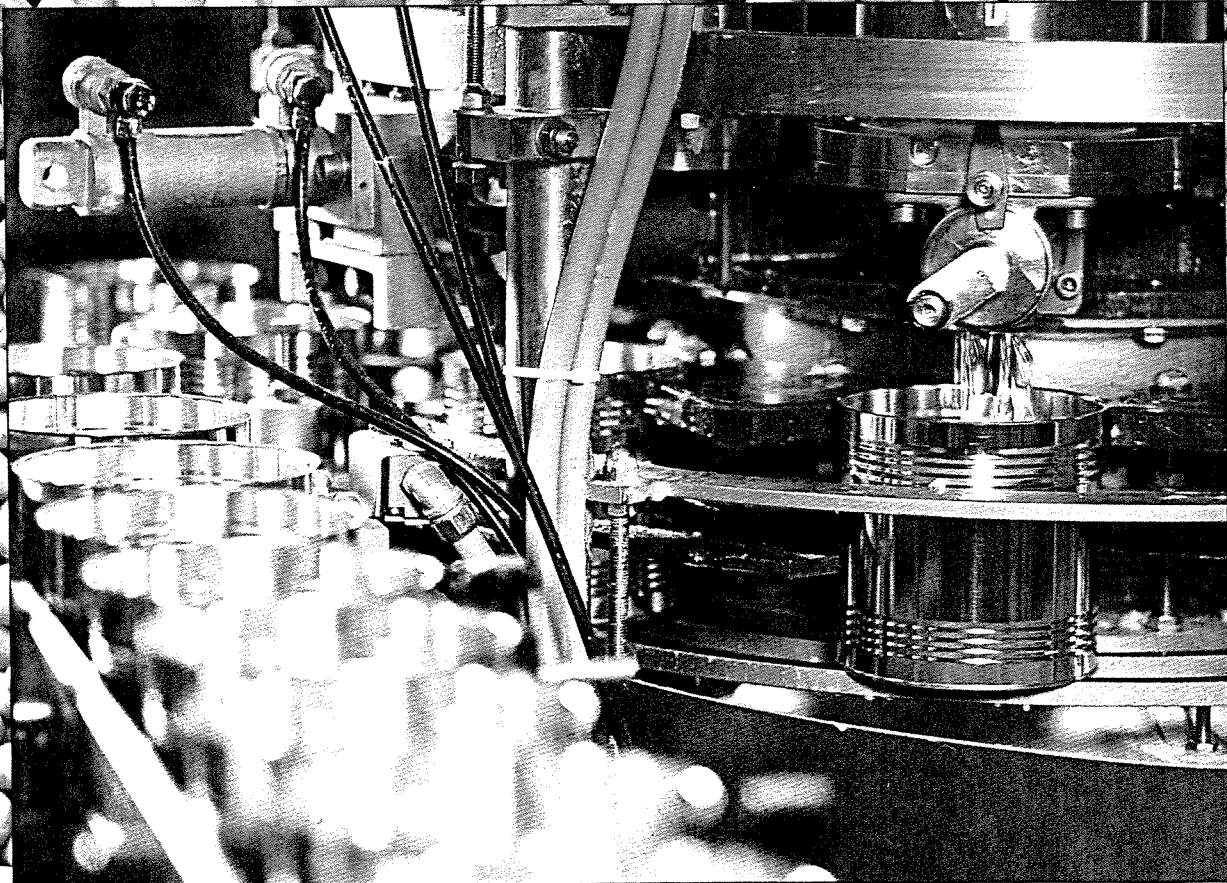
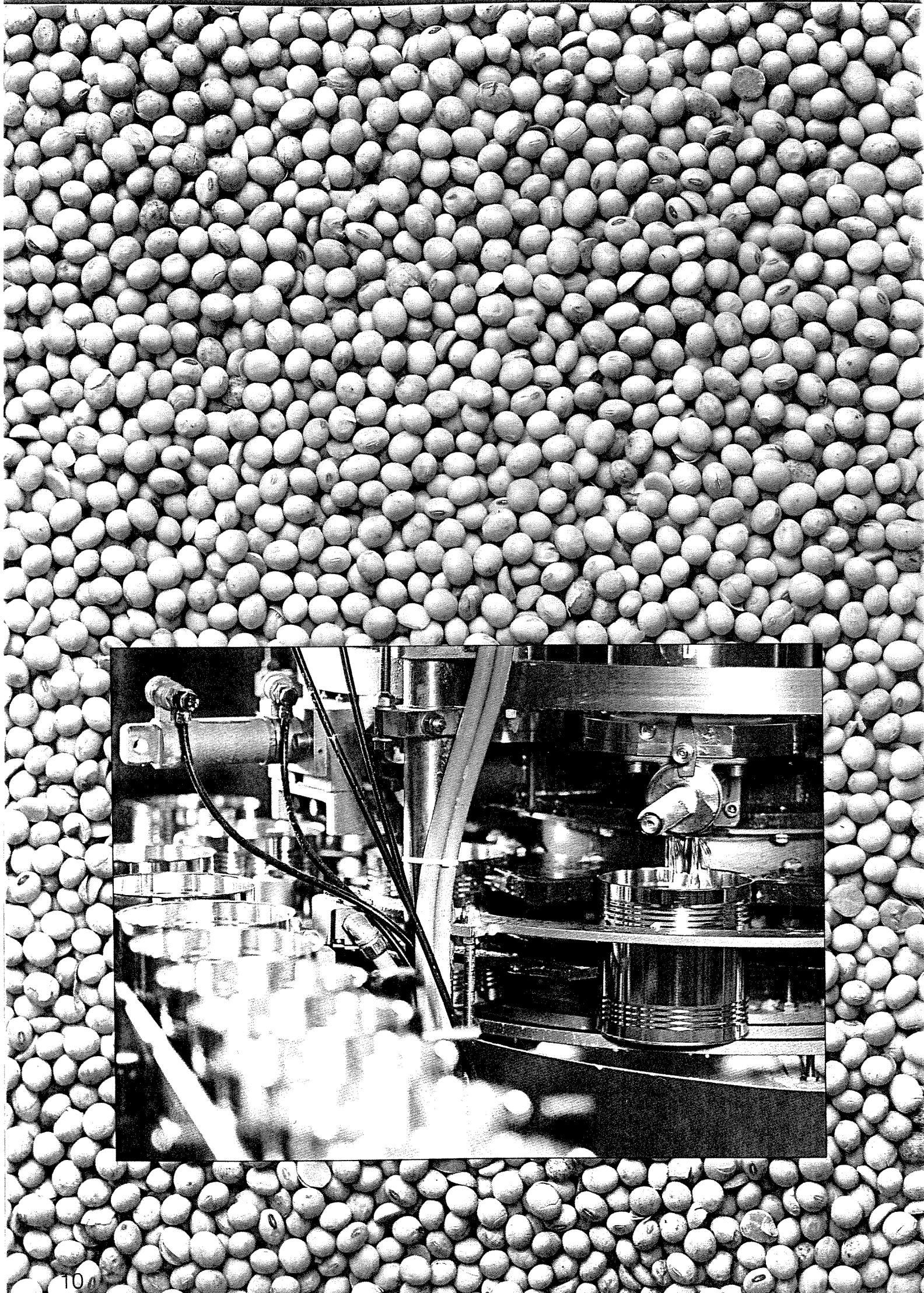

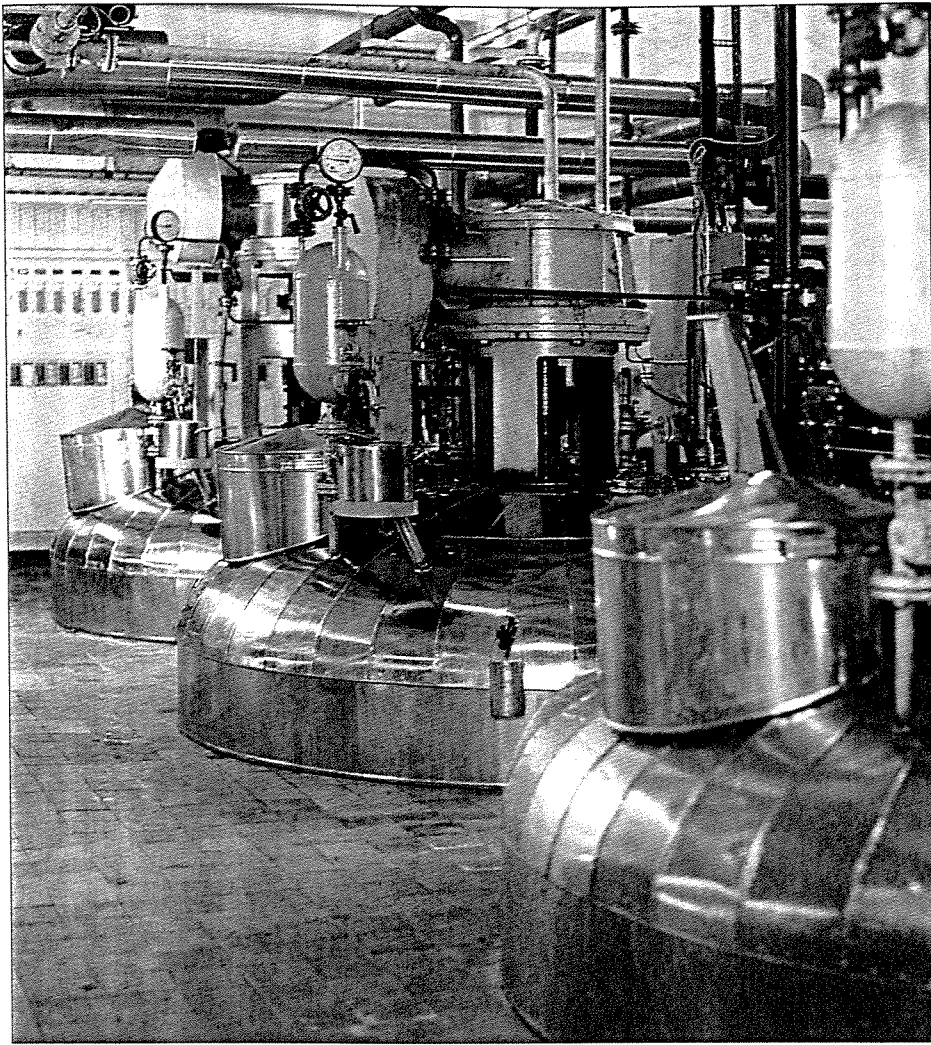

## DEODORIZING

Deodorizing is the final step in the process. Unwanted components are removed by oxygenfree steam under vacuum to produce an odour free and taste free fat ready for distribution.

## FILLING STATION

In our fully automatic filling stations, our quality products are filled into tanks and drums, or packed into cartons and tins, for distribution to customers in more than 50 countries.

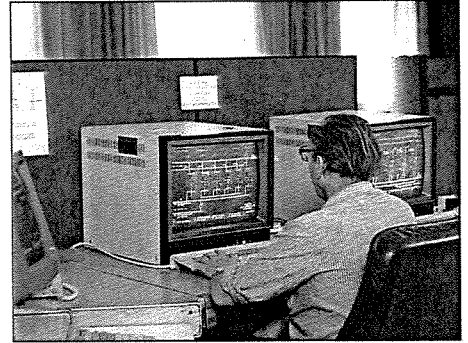

Most of the edible oils and fats going to the domestic market are delivered the same day as they are produced. Transport takes place in modern containers carried by road, rail or sea.

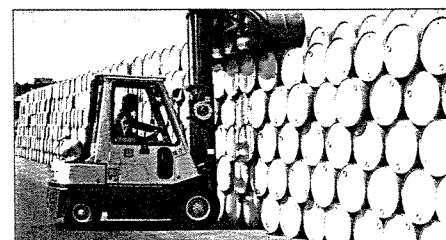
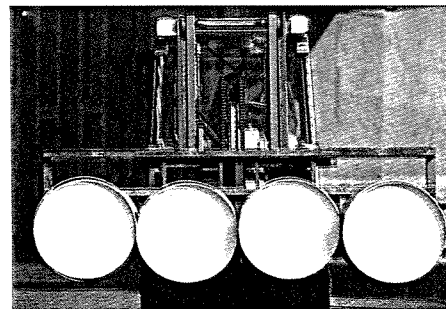

## ENVIRONMENT

Denofa is fully aware of its responsibility regarding pollution and the environment. Substantial amounts are invested annually on protective environmental measures.



PUSSEPAPIR

# QUALITY

Denofa's primary goal is to supply the markets with products of high and uniform quality.

Quality assurance, as a precaution, covers all steps of the production. Experienced specialists equipped with modern instrumental technology

are continually monitoring the process to ensure that the production is running according to standards.

From receipt of raw materials to distribution of end products, frequent sampling followed by chemical, physical, microbiological and

organoleptical analyses, guarantee a stable quality in accordance with the demands of nutritionists and consumers.

All products are dispatched with a certificate of analysis.

# RESEARCH AND DEVELOPMENT

In order to meet the demands and challenges of tomorrow, Denofa gives high priority to research and development.

In our laboratories and pilot plants, skilled scientists and technicians are working with advanced instruments on the continuous improvement of production equipment, methods and products, as well as the development of completely new products.

Much effort is spent on service to customers, whether this is a matter of the adaption of standard products or tailor-made specialities to fulfill specific product or processing requirements.

In addition, Denofa works closely with both national and international industrial partners and research centres. This in order to be updated, at all times, with the latest technology related to our business and our customers future needs.

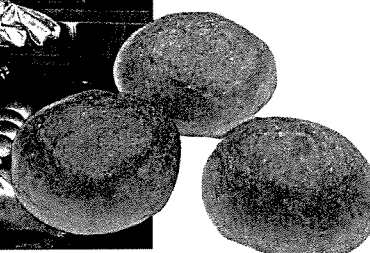
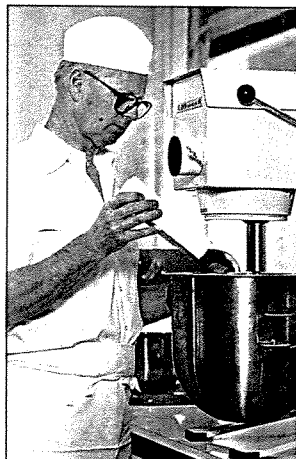
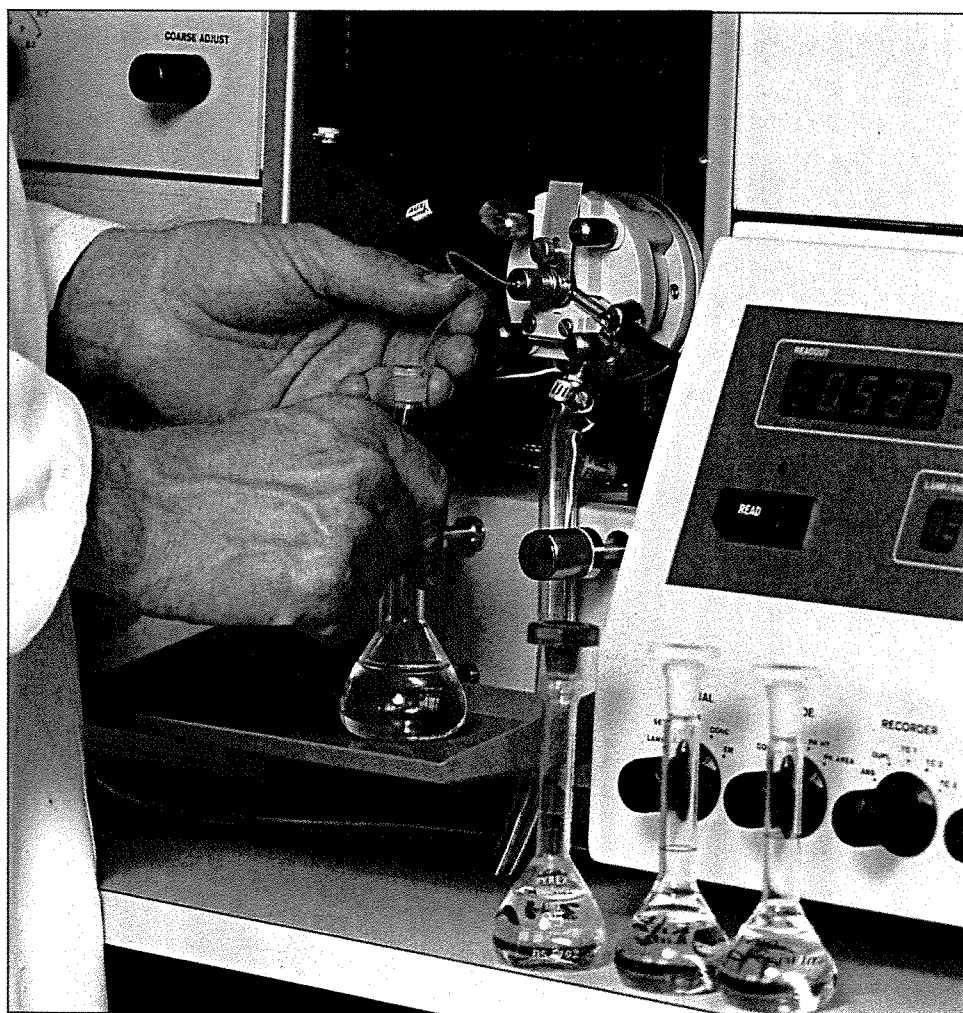



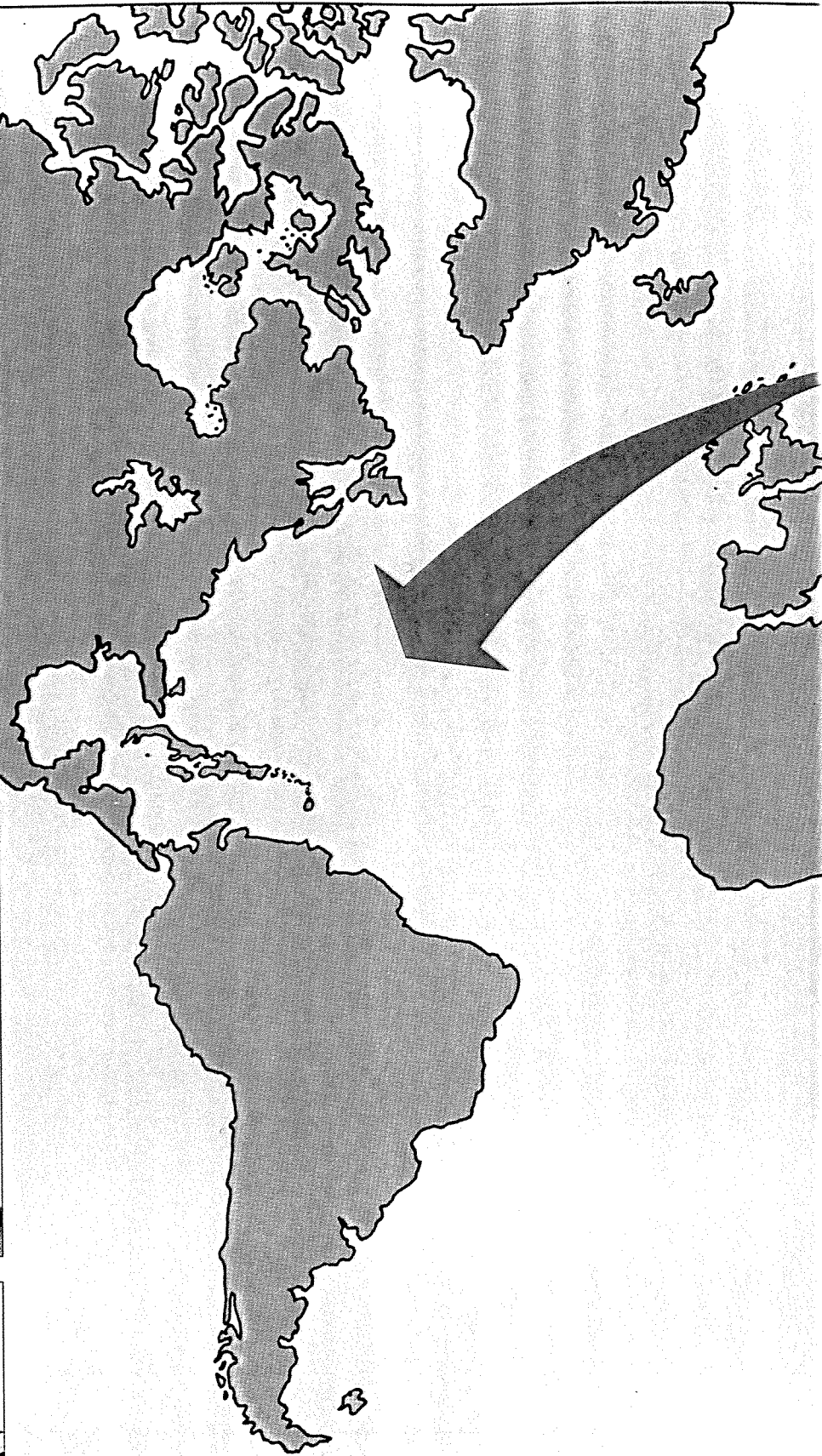
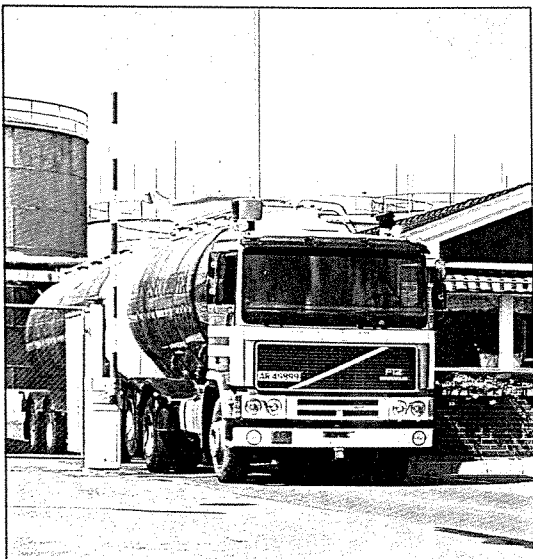

# DISTRIBUTION

The various Denofa products are distributed to customers in more than 50 countries. Different food industries comprise the majority of our customer group. The most important markets are located in Europe, Africa, Central America/The Caribbean Basin, Middle East and South East Asia.

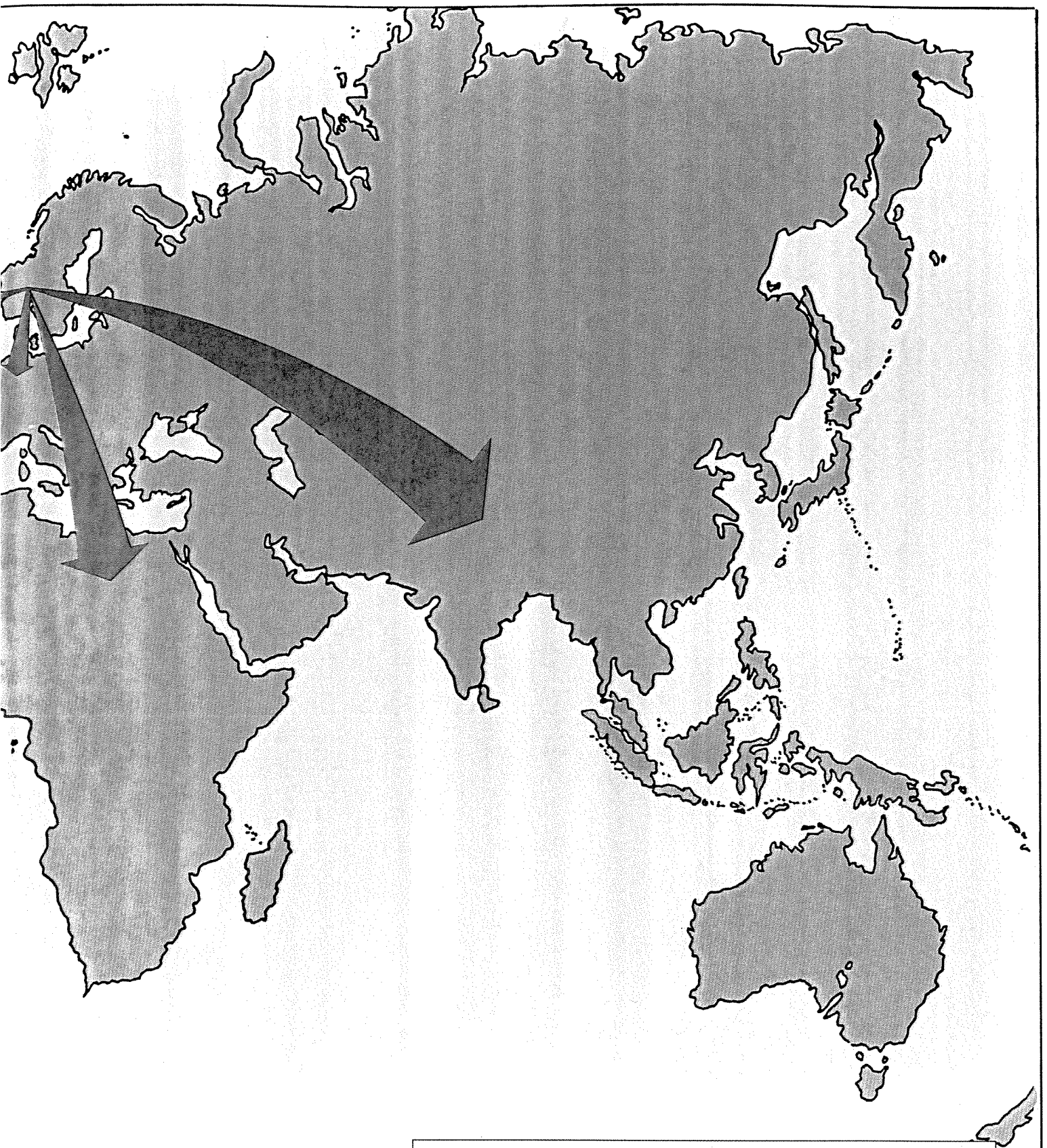

Both cartons, tins, drums and bulk shipments are used for the transportation of Denofa's products. Denofa makes use of its own 500 meter long quay for transportation by sea.

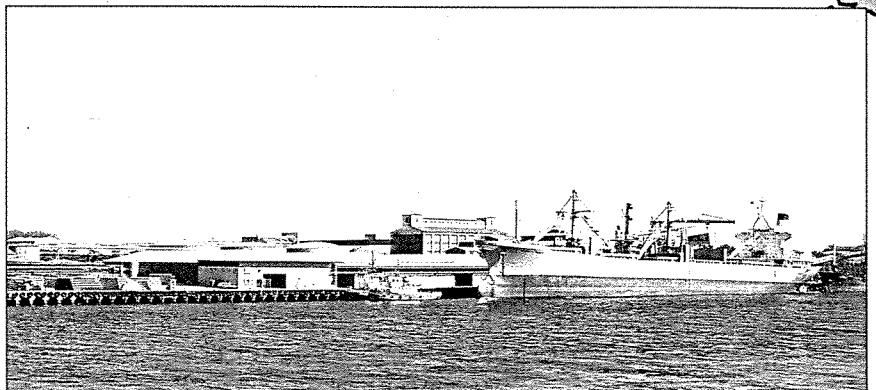

# PRODUCTS AND MARKETS

Denofa's marine and vegetable products are of a high, consistent quality, thus meeting the demands of the most sophisticated customer, whether food producers, technical industry or pharmaceutical companies.

With quality products from Denofa, margarine industries have excellent raw materials for their production. Denofa's products constitute the most important component in the production of household- and table margarines.

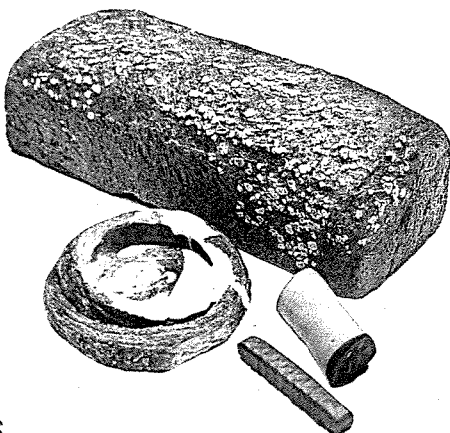
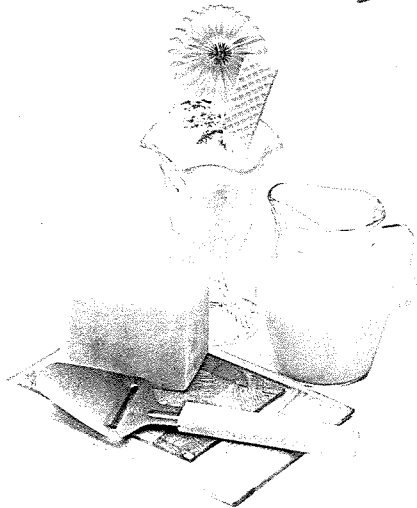
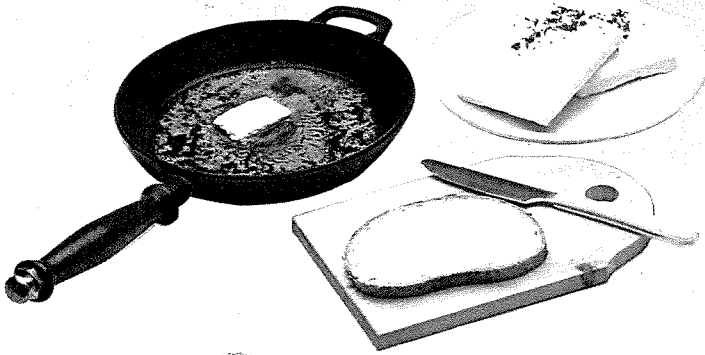
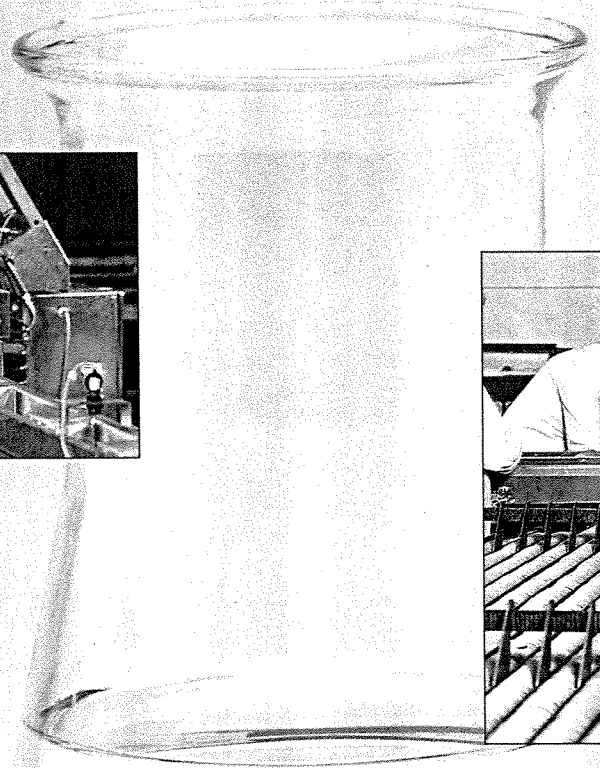
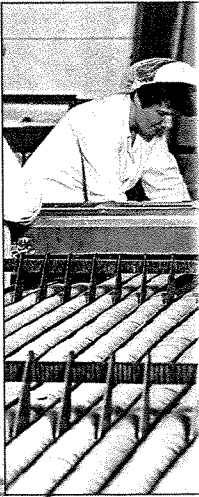
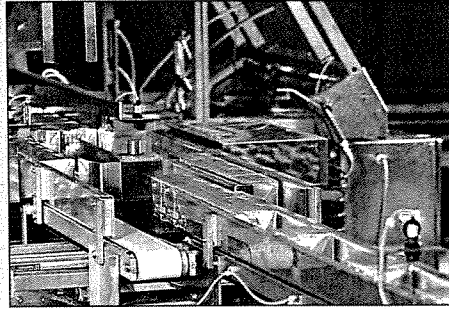

In an ever more demanding society, the consumers insist upon outstanding quality. With the help of fats from Denofa, bakeries in many countries are able to meet such demands.



Denofa's **Hardened Marine Fats**, whether produced as pure fats with melting points in the range of 25-52° C or in tailormade blends and shortenings, represent an interesting part of the product range offered.

**Vegetable Oils, Fats and Shortenings** are also offered with specifications in accordance with the preferences of domestic and international customers.

Denofa also supplies soya meal for feeding purposes.

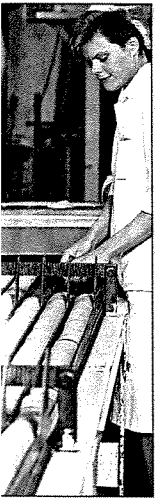

Biscuit factories throughout the world use Denofa's fats and shortenings in various types of biscuits.

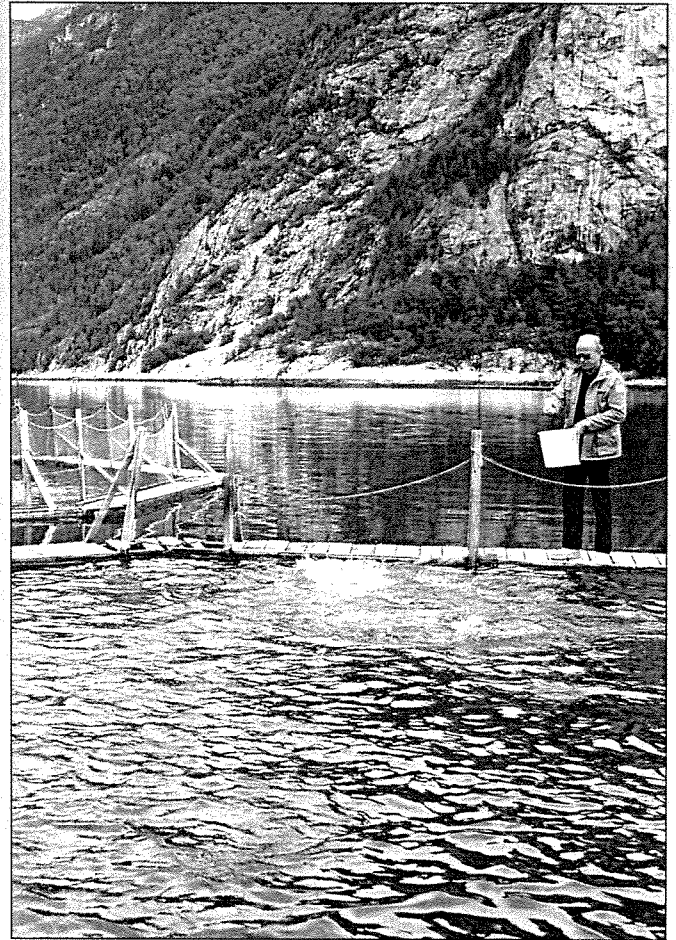
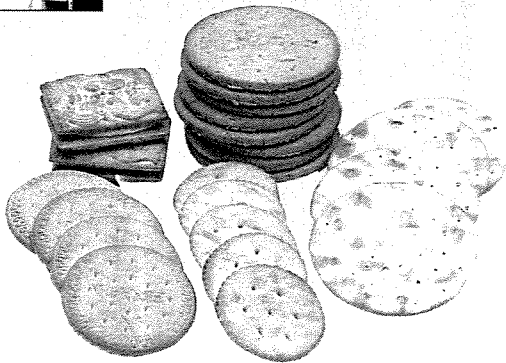

Denofa supplies both oils, soybean protein and lecithine for feeding Norwegian salmon, trout and other types of commercially farmed fish.

Denofa's feeding products are also an important part in poultry and animal fodder.

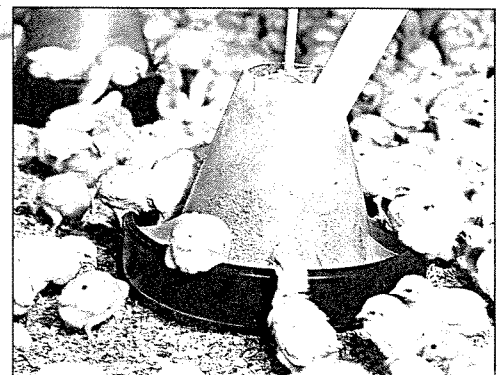

# A/S DENOFA OG LILLEBORG FABRIKER

De-No-Fa A/S merged in 1959 with A/S Lilleborg Fabriker, a leading company in the household products market. Together, the two companies now consist of:

**Edible Oils and Fats Division: (Denofa)** Manufacturing of edible oils, fats and meal for human consumption, technical use and feeding. Salesoffice in Oslo, production in Fredrikstad.

**Detergents Division:** Manufacturing and sales of detergents to private consumers in the Norwegian market. Production in Oslo.

**Industrial Detergents Division:** Manufacturing and sales to institutions and industries in the Norwegian market. Production in Ski.

**Toilet/Cosmetics Division:** Manufacturing and sales of toilet articles and cosmetics for the Norwegian market. Production in Oslo and Kristiansund.

**Subsidiaries:** Fredrikstad Blikk & Metallvarefabrikk A/S  
Industrial Containers (drums)  
Home's A/S: Household Textiles  
Peter Möller: Cod Liver Oil

A/S Denofa og Lilleborg Fabriker is a part of Orkla A/S, one of the major industrial groups in Norway, with activities in Consumer Goods, Media, The Processing Industry and in Investment.





PRODUCTION:

Øraveien 2, P.O. Box 33,  
1601 Fredrikstad  
Norway

SALES OFFICE:

Sandakerveien 56, P.O. Box 4236 Torshov,  
0401 Oslo, Norway  
Tel.: 47 - 22 89 50 00 - Telefax: 47 - 22 22 45 43  
Telex: 71181 Deno N

# Miljøinformasjon

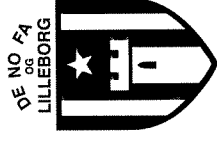

1995



A/S DENOFA OG LILLEBORG FABRIKER  
Fredrikstad

## INNHALDSFORTEGNELSE

Denofa – en hjørnesteinsbedrift i Fredrikstad i over 80 år .....	side 3
Kvalitetsprodukter fra Denofa .....	side 4
Denofas kvalitetssikringsprogram for helse, miljø og sikkerhet. HMS-strategi og mål, ledelsesansvar, medarbeideransvar .....	side 6
HMS-policy .....	side 7
Denofas kvalitetssikringsprogram for helse, miljø og sikkerhet .....	side 8
Modernisering og oppgradering av ekstraksjonsverket .....	side 9
Biologisk renseanlegg – FREVAR. Kapasitet og renseresultater .....	side 10
Renseanlegg – ombyggingstiltak 1995. Økt renseeffekt og driftssikkerhet .....	side 11
Tekniske miljøanalyser ved Denofa .....	side 12
Planlagte miljøtiltak 1995 .....	side 13
Prosjekt for materialgjenvinning. Brukt blekejord fra Denofa som leirjord i produksjon av Leca .....	side 15
Utvikling av miljøteknologi i Denofa. Forbrenningsanlegg som utnytter energi og løser miljøproblem .....	side 16
Effektiv forbrenning – reduserte utslipp til luft .....	side 17
Minst mulig støy .....	side 18
Energisparetiltak .....	side 19

## DENOFA – EN HJØRNESTEINSBEDRIFT I FREDRIKSTAD I OVER 80 ÅR

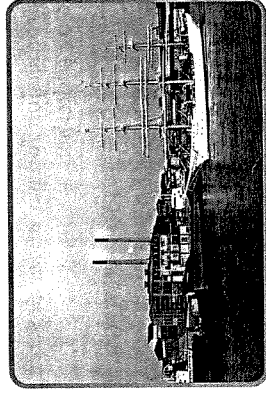

### DE NORDISKE FABRIKER A/S (DE-NO-FA) BLE GRUNNLAGT I 1912.

Fra starten og frem til i dag har bedriften gjennomgått en kontinuerlig omstilling, både når det gjelder produkter, markeder og prosesser.

Ved Denofas fabrikkanlegg i Fredrikstad i dag, produseres årlig ca. 120.000 tonn oljer og fett basert på marine og vegetabiliske råstoffer, samt 240.000 tonn fôrmed.

Denofa har i dag 300 ansatte og er Norges eneste produsent av oljer og fett til næringsmiddelindustrien og av soyaprotein til dyrefôr. Over 40% av den totale produksjonen eksporteres.

### MILJØPOLICY

Kriterier for helse, miljø og sikkerhet ligger til grunn for all Denofas virksomhet.

Når det gjelder miljø har vi lagt stor vekt på å investere i tiltak som har medført at vi har redusert våre utslipp til luft og vann i vesentlig grad.

Vår policy er at vår miljøinnsats stadig skal forbedres. Vi ønsker å medvirke til at dagens og fremtidens miljømessige utfordringer kan løses.



## KVALITETSPRODUKTER FRA DENOFA

Denofas produksjon foregår under de strengeste krav til hygiene, miljø og sikkerhet.

**VÅRT MÅL ER Å LEVERE PRODUKTER AV HØY OG JEVN KVALITET.**

Kvalitetssikring starter allerede ved valg av råstoffer. Gjennom hele prosessen, fram til sluttprodukt, blir det kontinuerlig foretatt kjemiske og bakteriologiske analyser for å sikre en høy kvalitet.

**ALLE VÅRE PRODUKTER KAN LEVERES MED EGET ANALYSESERTIKAT.**

Denofas marine og vegetabiliske produkter er viktige komponenter i produksjon av en rekke næringsmidler, samt tekniske og farmasøytiske produkter. Våre oljer blir blant annet brukt til intravenøs næring på sykehus.

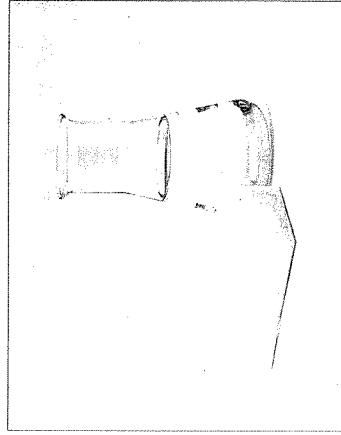

## KVALITETSPRODUKTER FRA DENOFA

Denofa leverer soyamel til førkunder i inn- og utland. Våre førprodukter inngår som viktige komponenter i fôr til dyr og oppdrettsfisk.

Råstoff til marine oljer kommer fra havområder utenfor Norge, Island, Japan og Syd-Amerikas vestkyst. De soyabønnene som benyttes kommer fra USA og Syd-Amerika.

Alle råstoffene er egenartede og behandles individuelt for å ta vare på den høye kvaliteten. Vi kjøper optimale kvanta slik at vi alltid har gode sikkerhetslagre, noe som samtidig sikrer en jevn kvalitet på våre produkter.

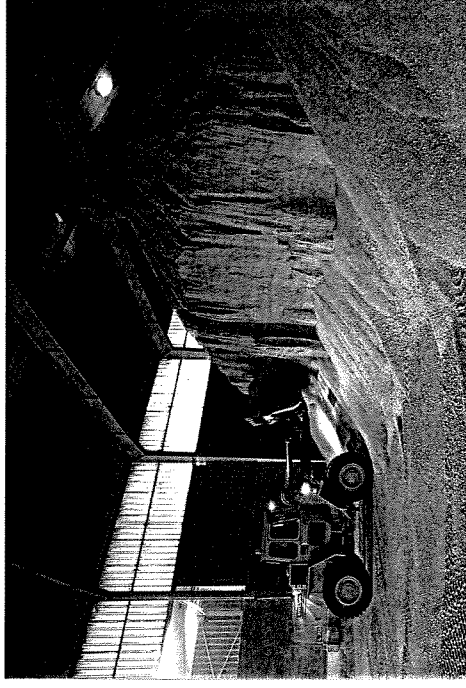

# DENOFAS KVALITETSSIKRINGSPROGRAM FOR HELSE, MILJØ OG SIKKERHET

HMS-strategi og mål, ledelsesansvar, medarbeideransvar

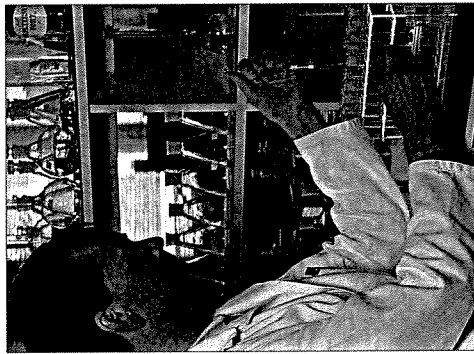

Ved Denofa, Fredrikstad, har vi et integrert kvalitets-system som ivaretar krav til både produkter og prosesser.

Denofas produkter tilvirkes under de strengeste krav til hygiene. Ved all produksjonsvirksomhet er krav til helse, miljø og sikkerhet prioritert på lik linje med bedriftens øvrige kvalitetskrav.

Denofa baserer sin kvalitetsstyring på ISO 9000 standarden samt Forskrift om internkontroll.

Teknisk miljøanalyse inngår i vårt internkontrollsystem.

I tillegg har bedriften utarbeidet en egen HMS-strategi med egne målsettinger som alle ansatte er med på å nå.

Kvalitetssystemet omfatter alle aktiviteter innen vårt organisasjonsområde, og er utbygget slik at enhver ansatt kan ta ansvar for kvaliteten av eget arbeide.

## HMS-POLICY

Spiseoljedivisjonens hovedmål er å være en foretrukket leverandør av spiseoljer og soyamel-produkter. En viktig forutsetning for å oppnå dette målet er arbeidsplasser hvor trivsel og minimal risiko er satt i fokus.

Dette vil vi oppnå ved en kontinuerlig og systematisk fokusering på Helse, Miljø og Sikkerhet på lik linje med produksjon og produktkvalitet.

Prioriterte områder innen HMS-arbeidet er:

- Helse
- Personskader
- Internt og eksternt miljø
- Brannforebyggende tiltak
- Beredskap
- Skade på utstyr
- Fysisk sikring

Myndighetenes krav og retningslinjer er grunnleggende leveregler i HMS-arbeidet.

For å lykkes i dette, er det avgjørende at vi alle bidrar til at prosedyrer og instruksjoner følges. Vi hjelper både bedriften og hverandre ved et positivt bidrag.

Sikring av vårt ytre miljø skal oppnås gjennom å fremme miljøbevissthet i alle ledd og aktivt arbeide for forbedring. Vi skal vektlegge forebyggende miljøarbeide samt utvikle og bruke ny viten og teknologi på miljøområdet, særlig når det er mulig å gjøre dette til et konkurransefortrinn.

Våre holdninger skal være preget av åpenhet.

Innsatsen som hver enkelt av oss gjør for å verne om Helse, Miljø og Sikkerhet, vil samlet bli målt og vurdert mot de mål som vi setter oss.

# DENOFAS KVALITETSSIKRINGSPROGRAM FOR HELSE, MILJØ OG SIKKERHET

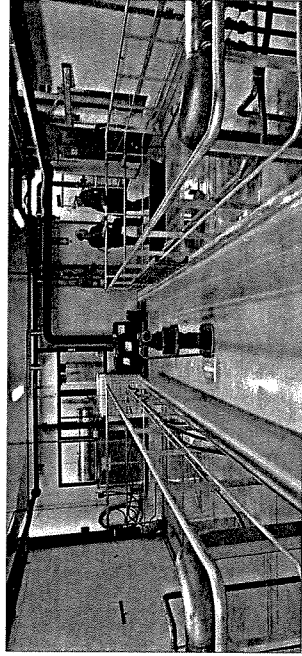

## INTERNE REVISJONER

Med interne revisjoner sikrer vi at kvalitetssystemet fungerer som det skal. De interne undersøkelser foretas av godkjente revisorer.

## BEREDSKAP

Beredskapsarbeid tas på alvor hos Denofa. Bedriften har et av landets best utbygde og mest effektive industrivern, med bl.a. egen brannstasjon sentralt på fabrikkområdet. Som beredskap ved eventuelle oljeutslipp til Glomma, har bedriften eget oljevernustyr.

## SIKRING AV FABRIKKANLEGGET

Sikringstiltak, kontroll og varslingsrutiner prioriteres høyt. For eksempel er sikringsutstyr for lekkasje på fabrikk-anlegget installert. Alle sentrale produksjonslokaler er sikret med skumanlegg. Utendørs lagertanker for olje er inngjerdet for å sikre oppsamlinger av eventuelle lekkasjer.

Det ble gitt ny driftstillatelse for ekstraksjonsverket i april 1994. Anlegget hadde da fått gjennomført en rekke utbedringstiltak som blant annet førte til betydelig reduksjon av utslipp til luft og vann.

I tråd med vår miljøpolicy, vil bedriften foreta kontinuerlige miljøforbedringer ved ekstraksjonsverket. I den forbindelse er teknisk miljøanalyse igangsatt.

## UTSLIPP TIL LUFT LIGGER UNDER EUS KRAV

Utslipp til luft består av heksan, støv og soyalukt.

Tillatt utslipp av heksan fra ekstraksjonsverket er 1.1 kg pr. tonn soyabønner. Utslippene måles ved å registrere forbruk av heksan pr. tonn soyabønner pr. løpende 12 måneders periode. Utslipp av heksan er i dag 0.7 kg og ligger under den foreslåtte utslippsgrensen i EU som er 0.8 kg. Resultatene viser at utslippet av heksan fra ekstraksjonsverket er redusert til en tredjedel i løpet av de siste åtte årene.

## UTSLIPP TIL VANN REDUSERT

Utslippene til vann fra ekstraksjonsverket er avløpsvann fra internt renseanlegg. Utslippsvannet har innhold av organisk stoff og utgjør 10-15% av bedriftens totale utslipp av KOF (kjemisk oksygenforbruk). Utslippsvannet inneholder små rester av heksan, og går av sikkerhetsmessige årsaker i separat avløp til Glomma. Tillatt maksimalutslipp fra ekstraksjonsverket av KOF er 300 kg pr. døgn. Siden oppstart i april 1994 er denne verdien ikke overskredet.

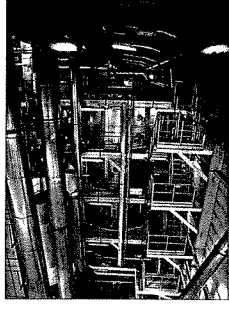

## RENSEANLEGG - OMBYGGINGSTILTAK 1995 Økt renseeffekt og driftssikkerhet

### ØKT PRODUKSJON - UENDREDE UTSLIPP TIL VANN

I forbindelse med ny driftstillatelse ønsker Denofa å øke produksjonskapasiteten med 30%. Forutsetningen er samtidig å øke renseanleggets kapasitet slik at en produksjonsøkning ikke medfører økte utslipp til vann.

### TEKNISK MILJØANALYSE AV BIOLOGISK RENSEANLEGG

Denofa har i løpet av 1994 gjennomført en teknisk miljø-analyse av renseanlegget på Frevar med tanke på forbedringsmuligheter. Miljøanalysen har fokusert på tiltak som vil gi bedre driftsstabilitet og økt renseeffekt.

### OMBYGGINGSTILTAK FOR ØKT RENSEEFFEKT

Ombyggingstiltak ved renseanlegget vil bli foretatt i løpet av 1. halvår 1995. Enkelte av tiltakene er allerede påbegynt.

Prioriterte tiltak er:

- Utjevningsbasseng på 500 m<sup>3</sup> for å øke stabiliteten på anlegget.
- Overgang fra pH-justering med kalk til natronlut.
- Installere anlegg for å styre og kontrollere luftinnblåsning, pH-regulering og slamretur.
- Etablering av omløp for hver enkelt prosessdel.
- Utbytting og supplering av utstyr for å forbedre driftskapasitet.

### BEDRE FILTERERING - REDUKSJON AV NIKKEL I SLAM

Denofa har til nå ikke kunnet behandle overskuddsslam i hovedrenseanlegget. Årsaken er for høyt innhold av nikkel i avløpsvann fra herdingsprosessen. Slammene er derfor deponert på Frevar.

Bedriften vil i løpet av 1995 innføre en forbedret filteringsprosess i herdningen. Vi har som mål å redusere nikkelinnholdet ned mot 2 ppm, som er akseptabelt nivå for renseanlegget.

Utslipp til vann fra Denofa er avløpsvann fra internt renseanlegg på fettfabrikken og biologisk renseanlegg på Frevar.

Nåværende grense for utslipp av KOF (kjemisk oksygenforbruk) er fastsatt til 1100 kg pr. døgn som årsmiddel og 1700 kg pr. døgn som maksimalverdi for en uke.

Den gjennomsnittlige belastningen på anlegget er lavere enn anleggets kapasitet, ca. 70% av full kapasitetsutnyttelse.

Denofa tilfredsstiller i dag utslippskravene. Midlere senseresultat for 1994 tilfredsstiller SF7s krav med god margin.

Denofa har samarbeid med Frevar om daglig drift av renseanlegget. Det har vært endel driftsproblemer i igangkjøringsperioden. Allikevel kan det sies at den kjemiske og biologiske nedbrytingen i anlegget i dag fungerer tilfredsstillende. Renseeffekten er ca. 77% KOF og ca. 94% BOF7.

### INTERNT RENSEANLEGG

Denofa har et internt renseanlegg på fabrikkken som renser kjølevann fra olje- og fettproduksjon. Dette er et effektivt flertrinns anlegg som består av fettfelle med dispersjonsvannanlegg. Dampningsfettfellen fungerer også som oppsamlingsstank ved eventuelle uhellsutslipp.



## TEKNISKE MILJØANALYSER VED DENOFA

Denofa har som målsetting kostnadseffektive løsninger som forhindrer at forurensning og avfall oppstår i produksjonen, og som i tillegg gir muligheter for resirkulering og gjenvinning.

Teknisk miljøanalyse er et verktøy som gir oss muligheter til å løse miljøproblemer ved kilden, som er den mest grunnleggende måte å redusere miljøbelastninger på.

I forbindelse med konsesjonsbehandling skal Denofa 1. halvår 1995 gjennomføre en teknisk miljøanalyse som omfatter hele fabrikk.

Vi har allerede gjennomført en analyse av det biologiske renseanlegget med tanke på tiltak som kan bedre stabiliteten og øke rensekapasiteten ytterligere. Utbedringstiltak av renseanlegget vil være ferdig 1. halvår 1995.

Den tekniske miljøanalysen av fabrikk starter med å kartlegge heksanutslipp fra ekstraksjonsverket for å vurdere mulighetene for reduksjon.

### SYSTEMREVISJON VED DENOFA

I løpet av 1994 har SFT gjennomført en omfattende systemrevisjon av Denofas styringssystem.

Følgende områder ble kontrollert: Håndtering av spesialavfall, håndtering av kjemikalier, utslipp til vann fra Fettfabrikken Syrehus via det biologiske renseanlegget på Frevar.

SFT benytter ulike kontrollmåter for å undersøke om bedriftene overholder gjeldende krav. Systemrevisjon er den mest omfattende og tidkrevende kontrollformen. Her gjennomgås hele eller deler av bedriftens styringssystem for å sikre at de krav som er stilt blir overholdt.

SFTs rapport beskriver de avvik og anmerkninger som ble avdekket innen de kontrollerte områder.



Teknisk miljøanalyse vil omfatte fysisk, teknisk gjennomgang av virksomheten med tanke på miljø og ressursbruk. Det vil særlig bli fokusert på forbedrende tiltak som kan redusere utslipp og avfall ved kilden og utnytte muligheter for internt gjenbruk.

Den miljømessige gjennomgangen vil blant annet omfatte:

- Kartlegging av utslipp fra interne renseanlegg.

Bedriften har bygget et flertrinnsanlegg for effektiv rensing av kjølevann fra olje- og fettproduksjonen, samt sikring mot eventuelle uhellslutslipp. Anlegget består av fettfelle med dispersjonsvannanlegg.

Anlegget har vært under kontinuerlig forbedring og ytterligere tiltak vil bli vurdert ved miljøanalysen.

- Kartlegging av luktbelastende utslipp fra fabrikk

Lukt fra virksomheten er primært soyalukt fra ekstraksjonsverket. Lukten er ikke vurdert som helseskadelig. Det forekommer også luktslipp fra scrubberanlegg i fettfabrikken. Teknisk miljøanalyse vil vurdere kildene til luktslipp og mulighet for tiltak som reduserer eventuelle utslipp ved kilden.

## 2. PLANLAGTE MILJØTILTAK 1995

- Kartlegging av energisparetiltak  
Effektiv bruk av energi og varmegjenvinning er en høyt prioritert oppgave. Det foretas derfor en kontinuerlig oppgradering av energisiden i bedriften.
- Muligheter for å minimalisere avfall  
Avfallsminimering og utnyttelse av avfall til gjenvinnings tiltak er en viktig del av bedriftens miljøstrategi. Teknisk miljøanalyse vil vurdere ytterligere tiltak for avfallsreduksjon og gjenvinning.
- Kartlegging av utslipp av støv  
Det kan forekomme utslipp av støv til omgivelsene ved lasting og lossing av soyabønner og soyamel. Særlig ved ugunstige værforhold. I forbindelse med teknisk miljøanalyse vil utslipp av støv bli kartlagt for å finne løsninger som kan forhindre eventuelle støvbelastninger.

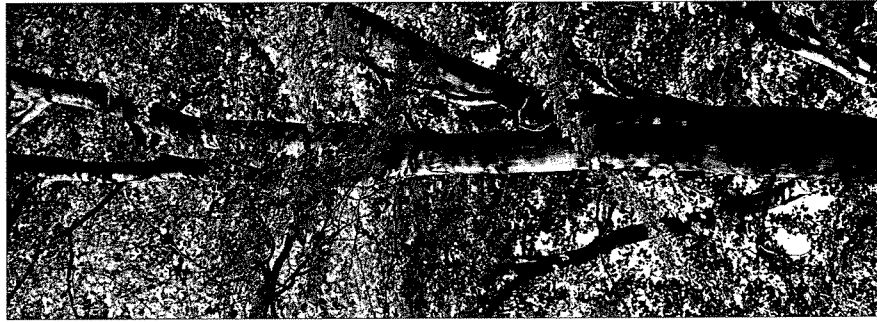

## PROSJEKT FOR MATERIALGJENVINNING

Brukt blekejord fra Denofa som leirjord i produksjon av Leca

- Brukt blekejord har historisk blitt behandlet ved deponering.  
Brukt filterhjul fra etterrafinerer av herdet fett har inntil nå blitt brent eller deponert på Frevar. Det har et innhold av nikkelkatalysator på ca. 1 % og kan av den grunn ikke bli behandlet på samme måte som blekejord.  
Denofa har nå startet et prosjekt som gir nye anvendelsesmuligheter for disse avfallsstoffene.  
Forsøk har vist at restprodukter av brukt blekejord og brukt filterhjul kan anvendes som verdifullt supplement og tilsats ved produksjon av Leca.  
Prosjektene er allerede igangsatt med tilslutning fra SFT.

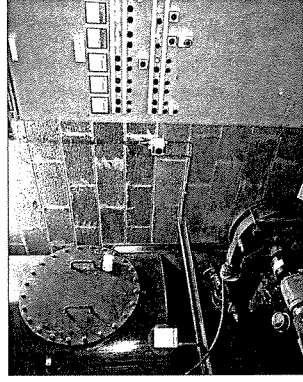

## UTVIKLING AV MILJØTEKNOLOGI I DENOFA

Forbrenningsanlegg som utnytter energi og løser miljøproblem

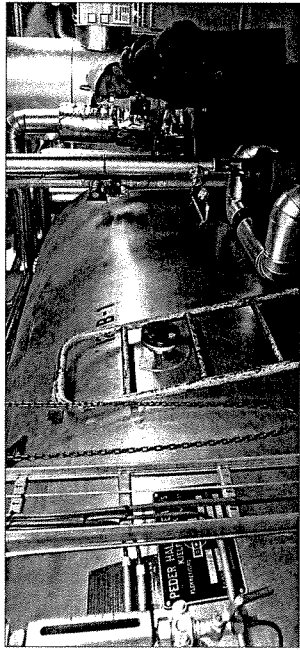

Prosessvann fra Jotun Polymer i Fredrikstad forbrennes hos Denofa.

Denofas egne ansatte har konstruert og utviklet denne prosessen som har ført til renere miljø. Utgangspunktet var at Denofa ville erstatte tungolje som brensel og lage et eget anlegg som både kunne destruere prosessvannet fra Jotun Polymer, samtidig som det ga energi ved å utnytte den verdifulle brennerværdien i prosessvannet.

Tidligere forbrenning med flere tusen liter tungolje, er dermed erstattet med et forbrenningsanlegg som ved minimal bruk av lettolje, destruerer miljøskadelig prosessvann fra Jotun Polymer, samtidig som det skaffer Denofa energi.

## EFFEKTIV FORBRENNING REDUSERER UTSLEPP TIL LUFT

Denofa produserer varme til oppvarmingsformål. Bedriftens varmebehov dekkes med 60% av eget forbrenningsanlegg, som er oljefyrt kjel og elektrodekjel som kan erstatte hverandre. De resterende 40% dekkes av Denofas miljøsam- arbeidsprosjekter med nabobedrifter. Det er damp som Denofa og Kronos Titan mottar fra Frevar, og det er Denofas egen miljøteknologi med forbrenning av prosessvann fra Jotun Polymer.

Bedriften har installert et såkalt OWE-anlegg (oljevann emulsjon) i den oljefyrt kjelen for å oppnå bedre forbrenning og minimalt utslipp av sot og støv.

Vi bruker svovelfattig olje for minst mulig utslipp av SO<sub>2</sub>. Med kombinasjonen OWE-anlegg og svovelfattig olje, oppnår vi minimale utslipp av sot og støv fra vår virksomhet.

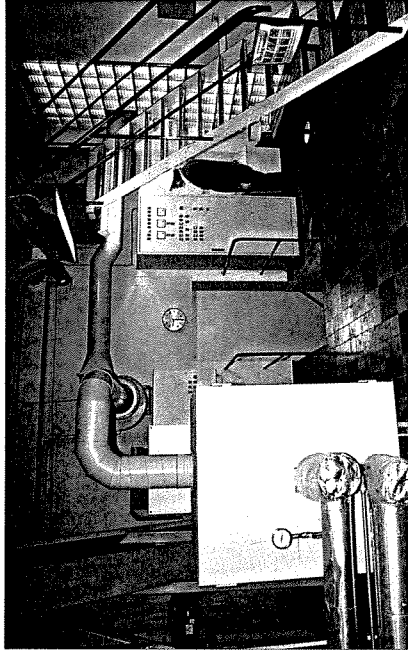

## MINST MULIG STØY

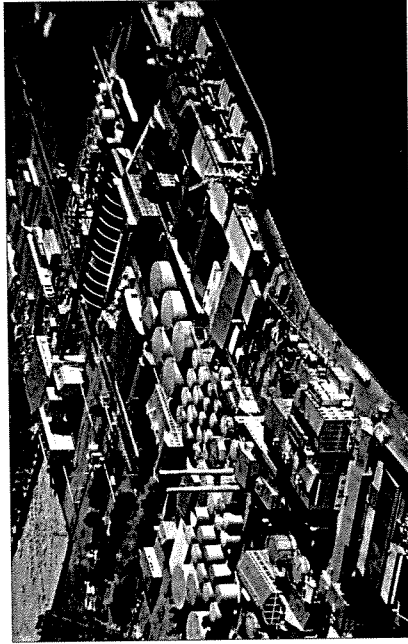

Kartlegginger av støyemisjonsnivå ved fabrikkene viser at vi overholder SFIs støykrav på alle målepunkter som er foretatt.

Denofas virksomhet ligger tett opp til boligstrøk, og vi er klar over at det kan forekomme støy som kan være sjenerende for beboerne i våre nære omgivelser.

Vi forsøker derfor å gjøre hva vi kan for å fjerne eller redusere mulige støykilder.

## ENERGISPARETILTAK

Energisparing er høyt prioritert hos Denofa. Vi har gjennomført en rekke ENØK-tiltak og søker kontinuerlig nye muligheter som kan gi bedre energituttnyttelse og miljømessige gode resultater.

Vi satses på varmegjenvinning og mest mulig energieffektivt utstyr. Blant annet er det nylig installert nytt utstyr på ekstraksjonsverket.

Ekstraksjonsverket har ikke eget fyringsanlegg, men bruker energieffektive kilder som damp fra bedriftens sentrale anlegg og fra Frevar.

Varmegjenvinningsanlegg på fettfabrikken er under ombygging.

Med OWE-anlegg installert i oljefyrt kjøle, oppnår vi maksimal forbrenning som sammen med bruk av svovelfattig olje reduserer utslipp til luft betydelig.

For å oppnå maksimal effektivitet og kontroll, er vi i gang med å forbedre vårt system for energioppfølging.

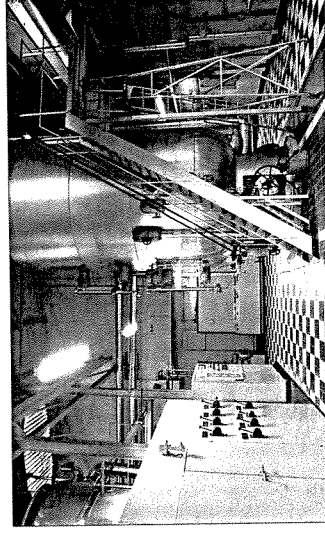



# DENOFA - FREDRIKSTAD

Oils and fats :  
Domestic  
Export to 40 countries

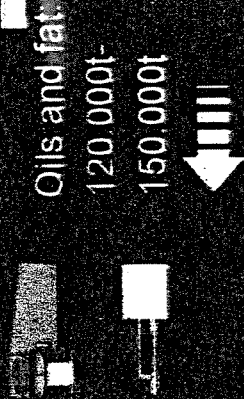

Refinery

Soymeal to :  
Norway  
Sweden  
Denmark

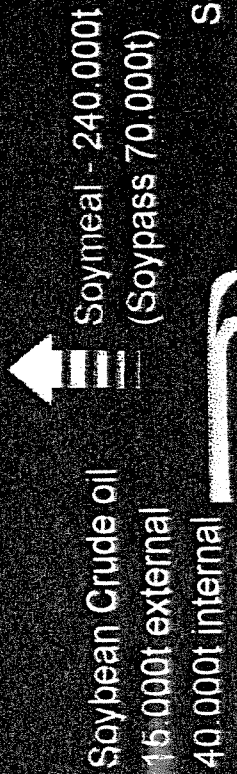

Other oils:  
Fish oils = 70.000t  
++  
Veg. oils = 15.000t  
++

Soybeans from :  
Argentina  
Brasil  
USA

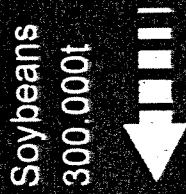

Soybean crushing plant

Soymeal - 240.000t  
(Soypass 70.000t)

## Appendix 10: Memorandum

Oslo, Norway

18th -25th of August 1995

### **Memorandum from the working-study visit of POLTEGOR Institute representatives at the Norwegian Institute for Water Research (NIVA)**

During the days 18th-25th of August 1995 the working-study visit of three POLTEGOR researchers took place at NIVA.

The aims of the visit were:

1. Starting up the collaboration between POLTEGOR Institute, Wroclaw, Poland and NIVA, Oslo in the area of environmental technologies with active participation of the: National Risk Management Engineering Laboratory, US-EPA., Cincinnati, Ohio, USA.
2. Inviting NIVA to participate in organization of the planned NATO-sponsored workshop on Environmental Technologies and Measurements for East European Countries in September 1996.
3. Estimate the potential institutions and industrial partners for joint Polish-Norwegian activities in the environment protection area.

The visit has been realized according to the program attached.

Conclusions:

1. NIVA and POLTEGOR Institute agreed to start the collaboration in the following aims:
  - Application of the electro-kinetic techniques to control the heavy metals leakages in contaminated soils and natural waters.
  - Application of membrane technologies in water & wastewater treatment.
  - Looking for sources and applications of natural sorbents in order to control the emission of heavy metals transport in contaminated soils and natural waters.
  - Employing of the natural sorbents as food components in agriculture and animal-breeding.
2. NIVA declared interest in active participation in co-organizing of the planned workshop. The details of the participation will be define after final decision on the acceptance of the preliminary program by NATO.
3. The institutions visited (ELKEM-Mangan PEM in Porsgrunn, State Pollution Control Authority (SFT) in Oslo and A/S DENOFA og LILLEBORG Fabriker, Fredrikstad) have expressed their interest in continuing started discussions on the technology transfer and experimental activities.

The memorandum of the visit were presented and discussed at the Polish Embassy in Oslo in order to estimate the best ways of implementation of the results of the visit.

Polish delegates express their deep thanks for professional arrangement and hospitality of NIVA employees, and particularly to Grazyna Englund, responsible for the program of the visit.

Polish side:

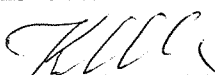
  
prof. Kazimierz Ukleja

Norwegian side:

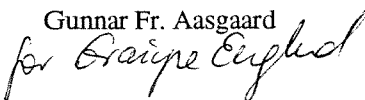
Gunnar Fr. Aasgaard  

**Norwegian Institute for Water Research**

P.O. Box 173 Kjelsås    Telephone: + 47 22 18 51 00  
N-0411 Oslo            Telefax:     + 47 22 18 52 00

By ordering the report, please use  
serial number 3521-96.

ISBN 82-577-3065-3