

Evaluation of the environmental impact from flue gas seawater scrubbing at the Qatalum aluminium smelter in Qatar

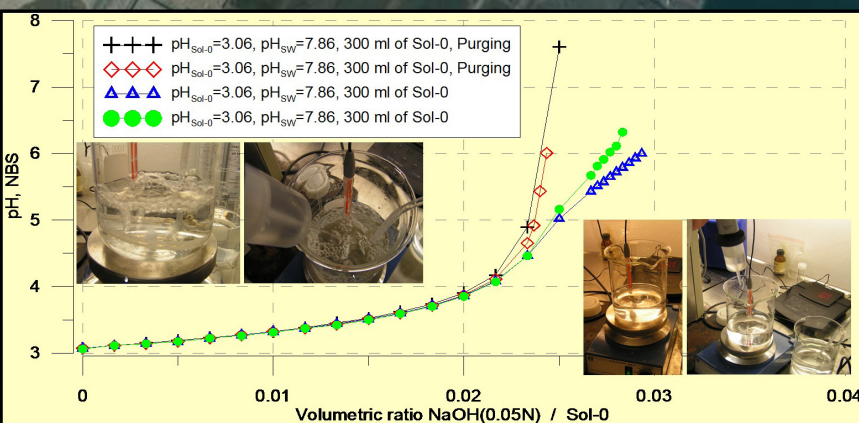
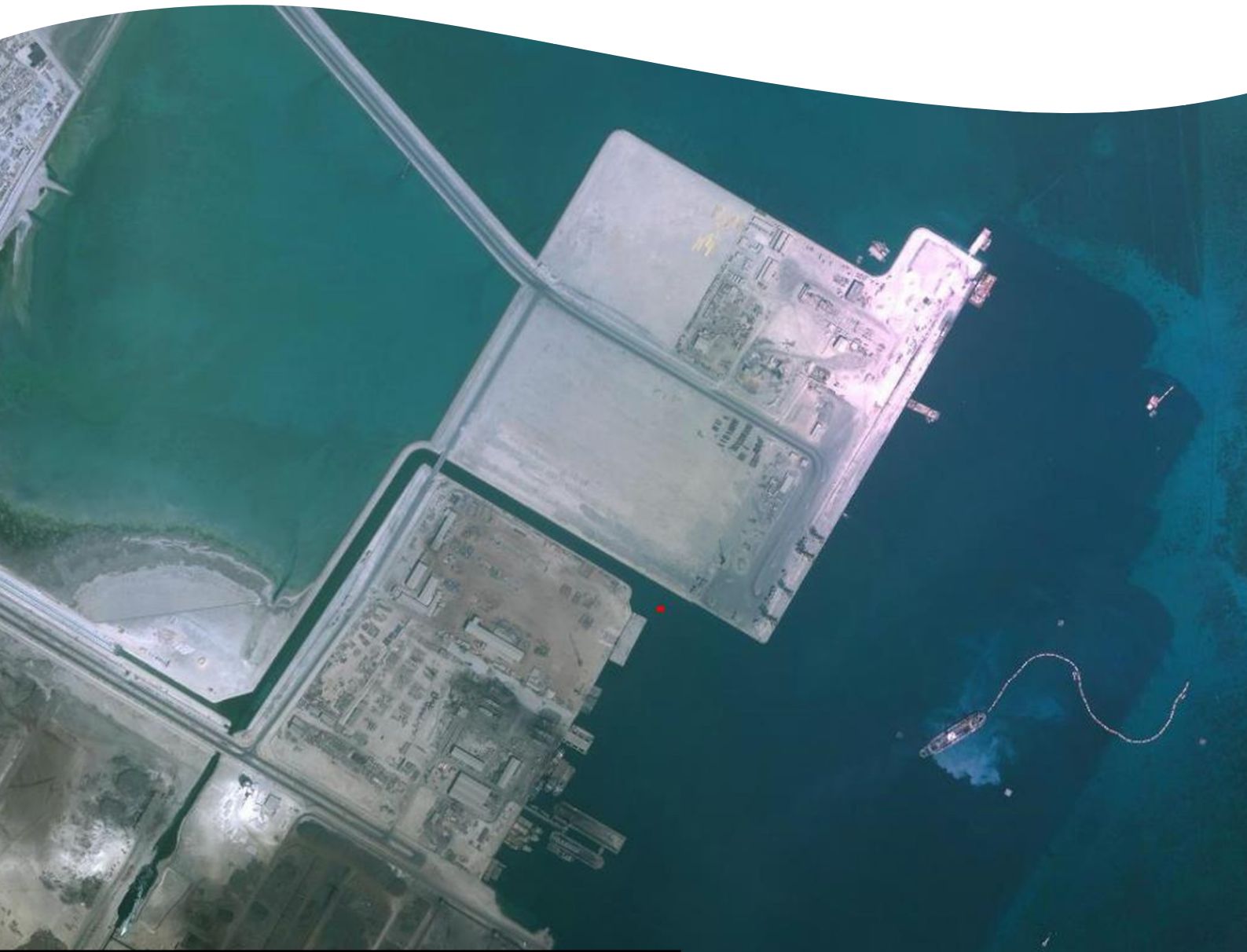

| | | | | |
|---|--|---|--|---|
| Main Office Gaustadalléen 21 NO-0349 Oslo, Norway Phone (47) 22 18 51 00 Telefax (47) 22 18 52 00 Internet: www.niva.no | Regional Office, Sørlandet Televeien 3 NO-4879 Grimstad, Norway Phone (47) 22 18 51 00 Telefax (47) 37 04 45 13 | Regional Office, Østlandet Sandvikaveien 41 NO-2312 Ottestad, Norway Phone (47) 22 18 51 00 Telefax (47) 62 57 66 53 | Regional Office, Vestlandet Thormøhlens gate 53 D NO-5006 Bergen Norway Phone (47) 22 18 51 00 Telefax (47) 55 31 22 14 | Regional Office Central Pirsenteret, Havnegata 9 P.O.Box 1266 NO-7462 Trondheim Phone (47) 22 18 51 00 Telefax (47) 73 54 63 87 |
|---|--|---|--|---|

| | | |
|--|---------------------------------------|------------------------|
| Title Evaluation of the environmental impact from flue gas seawater scrubbing at the Qatalum aluminium smelter in Qatar | Report No.. 5982-2010 | Date 2010.09.20 |
| | Project No.. O-29139 | Pages Price 70 |
| Author(s) Torgeir Bakke Evgeniy Yakushev Morten Schaanning Steven Brooks | Topic group Marine micropollutants | Distribution |
| | Geographical area Qatar | Printed NIVA |

| | |
|----------------------------------|---------------------------|
| Client(s) Qatar Aluminium Ltd | Client ref. 4200001629 |
|----------------------------------|---------------------------|

Abstract

NIVA has made a revised EIA of the Qatalum scrubber effluent to the sea. The receiving water masses are highly dynamic with current velocities up to 60 cm/s and 1,5 m tidal range. The seafloor ecosystems have low diversity and seagrass beds are the only biotopes of concern. The maximum zone of impact from the effluent based on 4 different operational situations will be the upper few meters of the water column within a 250 m radius from the outlet. This area is already strongly influenced by the local ship traffic. The local seagrass beds will not be impacted. A survey performed by URS in 2008 gives together with other surveys an adequate description of the baseline environmental conditions. A monitoring program is proposed to verify the EIA predictions and identify any long term ecological impact of the Qatalum effluent.

| | |
|---|--|
| 4 keywords, Norwegian 1. Konsekvensutredning 2. Sjøvannsvasker 3. Forsuring 4. Oksygenforbruk | 4 keywords, English 1. Environmental Impact Assessment 2. Seawater Scrubber 3. Acidification 4. Oxygen Consumption |
|---|--|



Torgeir Bakke
Project manager



Kristoffer Næs
Research manager



Rainer Lichtenthaler
Senior Research Scientist

Evaluation of the environmental impact
from flue gas seawater scrubbing at the
Qatalum aluminium smelter in Qatar

Preface

On contract from Qatar Aluminium Ltd NIVA has produced a revised environmental impact assessment of the effluent to the sea from flue gas seawater scrubbing at the Qatalum plant in Mesaieed, Qatar. Contact person for Qatalum/Hydro has been Chief Engineer Leif Ongstad. At NIVA Senior Researcher Evgeniy Yakushev has been responsible for conducting laboratory experiments on neutralization and dilution of model effluents which were part of the contract, and has contributed to the final report with focus on pH and alkalinity issues. Senior Researcher Morten Schaanning has contributed to the evaluation of chemical aspects of the assessment and Researcher Steven Brooks to the toxicological aspects. Senior Researcher Torgeir Bakke has been project leader and responsible for producing the final report.

Oslo, 20.09.2010

Torgeir Bakke

Contents

| | |
|--|-----------|
| Summary | 7 |
| 1. Introduction | 11 |
| 2. Seawater scrubber effluent treatment | 13 |
| 2.1 Treatment processes | 13 |
| 2.1.1 Treatment options. | 13 |
| 2.1.2 Absorption of SO ₂ in seawater | 13 |
| 2.1.3 Neutralization and oxidation | 14 |
| 2.1.4 Aeration efficiency | 15 |
| 2.2 Technical description of the treatment facilities | 17 |
| 2.2.1 Scrubber effluent drainage pipes | 17 |
| 2.2.2 Sodium hydroxide storage | 17 |
| 2.2.3 Sodium hydroxide injection | 18 |
| 2.2.4 Distribution, collection and inlet chambers | 18 |
| 2.2.5 Aeration channel | 18 |
| 2.2.6 Process control and monitoring | 18 |
| 2.2.7 Discharge channel | 19 |
| 2.3 Key design parameters | 19 |
| 3. Characterization of the marine environment | 21 |
| 3.1 Coastal and seabed characteristics | 21 |
| 3.2 Currents waves and tide | 21 |
| 3.3 Hydrographical conditions | 22 |
| 3.4 Biological characteristics | 23 |
| 3.4.1 Pelagic ecology | 23 |
| 3.4.2 Benthic ecology | 24 |
| 3.5 Ecological elements of concern | 24 |
| 3.6 Pollution status | 24 |
| 3.6.1 Sea water | 25 |
| 3.6.2 Surface sediments | 25 |
| 4. Environmental impact evaluation principle | 27 |
| 5. Environmental quality standards | 29 |
| 5.1 Derivation of environmental quality standards (EQS) values | 29 |
| 5.2 EQS for factors of environmental concern | 29 |
| 5.2.1 Temperature | 29 |
| 5.2.2 pH | 30 |
| 5.2.3 Dissolved oxygen (DO) | 31 |
| 5.2.4 Sulphite as chemical oxygen demand (COD) | 31 |
| 5.2.5 Free residual chlorine (FRC) | 32 |
| 5.2.6 Scale inhibitor | 32 |
| 5.2.7 Other components | 33 |
| 5.3 EQS values applied | 33 |

| | |
|--|-----------|
| 6. Operational cases | 35 |
| 7. Change in pH during neutralization and ambient dilution | 39 |
| 7.1 Estimated supply of NaOH required for effluent neutralization | 40 |
| 8. Environmental impact assessment | 43 |
| 8.1 Ambient effluent dispersion and dilution dynamics | 43 |
| 8.2 Degree of impact from the factors of concern | 45 |
| 8.2.1 Temperature | 45 |
| 8.2.2 pH | 45 |
| 8.2.3 Dissolved oxygen (DO) and sulphite expressed as COD | 46 |
| 8.2.4 Free residual chlorine (FRC) | 47 |
| 8.2.5 Salinity | 47 |
| 8.2.6 Alkalinity | 47 |
| 8.2.7 Sulphate | 47 |
| 8.2.8 Sulphide | 47 |
| 8.2.9 Scale inhibitor | 48 |
| 9. Conclusions | 49 |
| 10. References | 51 |
| Appendix A. Technical drawing of the scrubber effluent treatment system | 53 |
| Appendix B. The NIVA neutralization/dilution experiments | 55 |
| Appendix C. The ESC neutralization/dilution experiments | 65 |
| Appendix D. Effluent and environmental monitoring | 75 |

Summary

Background

Qatalum, as a joint venture company between Qatar Petroleum (QP) and Hydro Aluminium (Hydro), is completing the construction of an aluminium smelter in Mesaieed, Qatar. The plant has fume treatment plants with dry scrubber units to remove fluorides and dust, and seawater wet scrubbers to remove SO₂. The acidic effluent from the wet scrubbers is mixed with cooling seawater and the combined effluent is then aerated and discharged to the sea through an open channel together with cooling water from Qatar Steel.

In 2008 The Norwegian Institute for Water research, NIVA, performed an EIA of the potential impact of the effluent on the receiving marine environment. The Qatari Ministry of Environment (MoE) has requested Qatalum to verify some of the assumptions and calculations that this concept is based upon. The present document is a revised and extended version of this EIA.

Local ecological conditions

The local coastline is strongly modified by the industrial development. The water depth is < 25 m. The bottom along the berths has been dredged to 10-15 m depth for navigation. The seabed consists largely of fine sand and silt and very little clay. The mean spring tidal range is 1,5 m. Current velocity is in the range 0.03 - 0.61 m/s directed predominantly along shore between 100° and 300°. The seawater temperature outside the industrial site varies with season in the range 20-22 °C during January-February, and highest 35-37 °C during July - September. The water column in late summer is slightly stratified with higher temperature towards the surface. Salinity is generally in the range 40-50 PSU. Level of suspended solids is mostly below 10 mg/l. Levels of DO are in general in the range 5 – 7 mg/l (86 – 121 % saturation) and bottom water saturation is never below 90 %. No indication of oxygen depletion has been reported. The typical seawater pH is in the range 8,0 – 8,3.

Overall zooplankton diversity is high and with predominance of copepods and larvae of benthic fauna. The benthic communities within the Arabian Gulf are low in biodiversity and abundance. In the dredged navigational channel the visible flora and fauna is very sparse, being considerably richer and with more undisturbed seagrass communities in the shallow area northeast of the channel. The marine biotope of particular concern in the area are the seagrass beds. These are most dense at the 2-6 m depth range.

Pollution status

Levels of heavy metals in the seawater seem well within the standards given by the Qatar MoE and correspond to the background range for Norwegian coastal waters. No traces of arsenic, nickel, vanadium, selenium, mercury or tin have been detected. Earlier studies have detected levels of PCB which suggest some risk of bioaccumulation. The waters are clearly oil contaminated probably from many sources. Free residual chlorine has been detected in seawater samples possibly from discharges of cooling water. Bottom sediments show slight elevation of certain heavy metals, whereas oil hydrocarbons appear to be at background for marine sediments. Radioactivity levels have not exceeded background levels.

EIA Principle

A typical PEC/PNEC approach was adopted. This compares Predicted Environmental Concentrations (PEC) of each discharge component with a Potential No Effects Concentration (PNEC) of the same component to determine the spatial extent of an environmental impact zone in the recipient. As long as the ratio $PEC/PNEC < 1$, there is no risk of environmental effects. The main factors of environmental concern related to effluents from wet scrubbing are pH, alkalinity, DO, and sulphite. Additional factors of concern due to the cooling water use are elevated temperature, FRC and anti-scaling agents.

MoE also required that sodium (Na^+ from NaOH neutralization), sulphate (SO_4^{2-}) and sulphide (S^{2-}) were assessed.

Operational cases covered

The revised EIA covers 3 operational cases:

- Case 1: Normal operation with NaOH neutralization, with (A) and without (B) mixing with Qatar Steel cooling water in the aeration channel.
- Case 2: As Case 1A, but with failure of NaOH neutralization.
- Case 3: As Case 1A with additional future mixing with QPCC process water in the aeration channel.

Environmental impact assessment

In Case 1A the pH will be the effluent factor that determines the overall geographical zone of impact (where $\text{PEC/PNEC} \geq 1$ for one or more of the factors of concern). In the worst case a 1:1 ambient dilution is required for pH to reach the PNEC. This will be achieved during primary mixing (where the effluent discharge velocity still has some influence on dispersion) and hence the maximum duration where organisms are exposed to a PEC/PNEC slightly above 1 is less than 1 minute. This is too short to cause any significant ecological impact.

In Case 1B the dilution to obtain $\text{PEC/PNEC} < 1$ is 2-3 times for both pH, overtemperature and dissolved oxygen (DO). As in Case 1A this will be achieved during primary mixing. The maximum duration where organisms are exposed to a PEC/PNEC slightly above 1 is less than 1 minute. Furthermore, the exposure will be episodic, only lasting for a few days at a time.

In Case 2 the factor determining the impact zone will be COD from oxidation of sulphite. In the worst case a dilution factor of 7 is required for a $\text{PEC/PNEC} < 1$ (14 if a very conservative EQS of 5 mgDO/l is used). This situation will only occur if the sulphite oxidation is spontaneous. A more likely situation is that the sulphite is gradually oxidised in the recipient. In that case there is no risk of a DO deficit and $\text{PEC/PNEC} < 1$ will be obtained during primary mixing. A 7 times dilution will be achieved within 250 m from the outlet, a zone that is already strongly influenced by the ship traffic to the Mesaieed Industrial City. Pelagic organism drifting with the water may be exposed to DO between 0 and 4,5 mg/l for a maximum period of about 15 minutes. This will not cause any significant impact on the local pelagic ecosystem. There is little risk that sea bottom organisms within the impact zone should encounter reduced DO since the plume will be dispersed in the upper waters.

In Case 3 a dilution factor of maximum 1 is needed to achieve $\text{PEC/PNEC} < 1$ for pH and overtemperature and less than this for all the other factors of concern. Hence the impact zone and exposure duration will be as in Case 1A.

The potential impact of FRC, scale inhibitor, gypsum, calcite and the ions Na^+ , SO_4^{2-} , and S^{2-} in the effluents has also been evaluated. From available information it is concluded that FRC, gypsum, and calcite will not be present in the effluent in any of cases, and none of the others will determine the extent of an impact zone for the effluent. It is also expected that alkalinity reduction will not cause any environmental damage.

Adequacy of the URS survey 2008 as an environmental baseline description

The objective of the URS survey was to describe physical, chemical and biological conditions in the local marine environment outside MIC and identify any sensitive receptors. The stations adequately cover the expected impact zone. An appropriate set of physical and chemical seawater parameters have been studied, and most of them should be included in a future monitoring program. PCBs, BTEX and TPH may be omitted since they are not expected to be linked to the Qatalum effluent. Measurement of COD in high saline water is unreliable due to chloride interference, and should be excluded. The URS

measurements of pH seem to be out of range found in other local studies, and one must ensure that the method used in future monitoring is reliable. Since the Qatalum plant is in operation an extension of the baseline description cannot be obtained. In the monitoring program the near zone conditions must therefore be assessed against both the baseline data available and conditions at appropriate reference sites.

Future environmental monitoring

A future environmental monitoring program is outlined in Appendix D. This should have the following purposes:

- Describe the natural change over time in environmental and biological parameters of concern.
- Identify significant deviations from the natural patterns of the various parameters that could be linked to the Qatalum effluent.
- Verify the reliability of the predictions in the EIA regarding the severity and spatial extent of any impact.
- Control whether a gradual increase in environmental effects occurs over long time.

Experiments on pH change during neutralization and dilution of a model scrubber effluent

NIVA and ESC, Qatar, have independently and on basis of the same test protocol performed bench top experiments to describe the change in pH of a model scrubber effluent during neutralization with NaOH with and without air purging, and during subsequent dilution with normal seawater. These experiments are described in detail in Appendix B and C. Appendix B also contains the test protocol developed for these experiments.

1. Introduction

Qatalum, as a joint venture company between Qatar Petroleum (QP) and Hydro Aluminium (Hydro), is completing the constructing an aluminium smelter in Mesaieed, Qatar. The plant has four fume treatment plants consisting of dry scrubber units (alumina scrubbing) to remove fluorides and dust, and seawater wet scrubbers to remove SO₂. The concept for the treatment of the acidic effluent from the wet scrubbers is to mix it with cooling seawater from an adjacent steelworks and other plants under planning / construction. The combined effluent is then aerated and discharged to the sea through an open channel, called the MIC channel. The Qatari Ministry of Environment (MoE) has requested Qatalum to verify some of the assumptions and calculations that this concept are based upon.

In 2008 The Norwegian Institute for Water Research, NIVA, was awarded a contract from Hydro to perform an assessment of the potential impact from the seawater scrubber effluent on the receiving marine environment with and without mixing with other cooling water streams and subsequent aeration. This environmental impact assessment (EIA) was presented in a Technical Memo to Hydro dated 12.08.2008. It was limited to an evaluation of the natural dilution of the effluent plume with ambient seawater necessary to obtain agreed or proposed environmental quality standards for the discharge components of concern. In 2009 NIVA was contracted by Hydro and Qatar Aluminium Ltd to produce a revised version of the EIA. The revision should respond to comments given by the MoE to the previous version. The revision should also include a new assessment of the likely patterns in pH-change under neutralization/dilution of the scrubber effluent, based on new experimental data on pH changes patterns during mixing with seawater from sources around the Qatalum plant. These measurements were performed in January 2010 by Environmental Studies Centre (ESC) at the Qatar University.

The new contract comprised 5 tasks:

Task 1. Produce a procedural protocol to be used by ESC for experimental determination of changes in pH during sulphuric acid neutralization of the Qatalum effluent, during aeration, and during natural dispersion and dilution of the effluent plume in the receiving marine environment.

Task 2. Update the previous NIVA EIA report/memo of 12.08.2008, on basis of new information and requirements given by the Qatar Ministry of Environment (MoE).

Task 3. Propose an effluent and environmental baseline and monitoring program to verify the impact predictions given in the EIA.

Task 4. Validate sub-reports from adjoined studies produced by other consultants and experts, and produce an overall summary report of all the studies performed by NIVA and other consultants.

Task 5. Perform analysis of sulphite and sulphide content in the outlet water from a scrubber of the Qatalum type in operation in Norway.

The present report covers Tasks 1 - 4.

2. Seawater scrubber effluent treatment

This chapter outlines the technical features of the effluent treatment system downstream of the SO₂ scrubbers at the Qatalum potlines, and the underlying chemical processes. A more extended description is given in Appendix A.

2.1 Treatment processes

2.1.1 Treatment options.

Different options for effluents treatment have been considered all with the aim of providing neutralisation of pH (>6), removing COD in the form of bisulphite (HSO₃⁻) and ensure a minimum oxygen level (DO>2 mg/l):

- Base case: Mixing the effluent with cooling water from other local sources with subsequent aeration in the existing MIC Northern Outfall Channel.
- Alternative 1: Build a new channel upstream the MIC channel, for blending with other sources and aeration, possibly also neutralization with NaOH or lime to meet the required pH before entry to the MIC channel.
- Alternative 2: Redesign of the bottom pits of the scrubbers in order to allow *in situ* neutralization and aeration in these pits.

Alternative 1 has been chosen since it will be a robust solution to meet the discharge requirements before entry to the MIC channel. It will also allow expansion to include future effluents from QPCC, M-Power and later expansions of Qatalum. Use of cooling water from others would reduce costs of chemical neutralization. This recommendation was submitted to MoE and later accepted.

2.1.2 Absorption of SO₂ in seawater

The seawater scrubbing process is based on the natural alkalinity of seawater where seawater is used to bind the acidic species of flue gases, particularly sulphur dioxide (SO₂). The dissolved sulphur dioxide converts to hydrogen sulphite ions, hydrogen sulphate ions and finally sulphate ions which are a natural element in seawater.

In the process the SO₂ of the flue gas is transferred from the gaseous phase into the dissolved phase which will be transformed into hydrogen sulphite HSO₃⁻ :

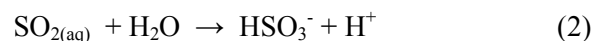

The hydrogen ions that are produced by this reaction will be neutralized to some extent by reaction with seawater bicarbonate:

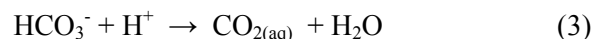

The flue gas also contains appr. 0.8 - 1% CO₂. This will also be absorbed in the scrubber, but only to a little extent since the water will be nearly saturated with CO₂ due to reaction (3).

The DO in the scrubber water will oxidize the bisulphite to sulphate:

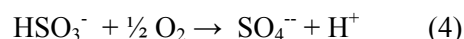

The overall equilibrium of these reactions gives a pH in the range of 5 - 5.5 at the scrubber outlet. Since the oxygen content is only sufficient to oxidize 15 – 20% of the bisulphite, the remaining will constitute a chemical oxygen demand (COD) of around 25 mg/l.

2.1.3 Neutralization and oxidation

In order to eliminate the COD (complete reaction (4)), and ensure a DO > 2 mg/l, more oxygen has to be added to the effluent by purging with air. Also neutralization has to take place before the aeration, since low pH will slow down reaction (4) and cause stripping of SO₂ to the atmosphere and since reaction (4) releases more hydrogen ions, thus lowering the pH further. Neutralization should ensure pH > 6 to the end of the aeration process.

One option is to use additional seawater for neutralization, taking advance of the natural seawater buffering capacity according to reaction (3). At design SO₂ load equal amounts of seawater and scrubber effluent are required. If sufficient supply of seawater is not available, sodium hydroxide NaOH is the preferred neutralization agent. The following reactions then take place:

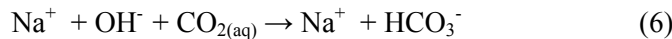
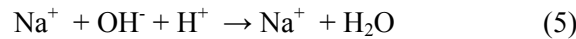

The use of the cheaper lime has been considered, but not chosen due to the risk of gypsum precipitation:



Also NaOH is simpler to handle, since it comes in liquid form, and is readily available from a near-by producer.

The quantity of seawater or NaOH required for neutralization depends on the actual level of sulphur in the anodes, which again mainly depends on the sulphur content of the coke. The plant is designed to manage up to 4%S in the coke, since such levels are expected in the future. However, the initial operation will be based on around 2.5% S in the coke.

The acid – base reactions above are instantaneous, and completion of the reactions is then only depending on physical mixing. The reaction between bisulphite and oxygen is not instantaneous. The rate of reaction depends on pH and temperature. The process of dissolving oxygen by air injection also takes some time, mainly depending on the bubble size.

Figure 1 shows the expected amount of NaOH required depending on the SO₂ load according to Lentjes' calculations (NIVA's and ESC's experiments indicate a lower NaOH demand, see Chapter 7). In this case QPCC would discharge approximately the same amount of water as Qatalum.

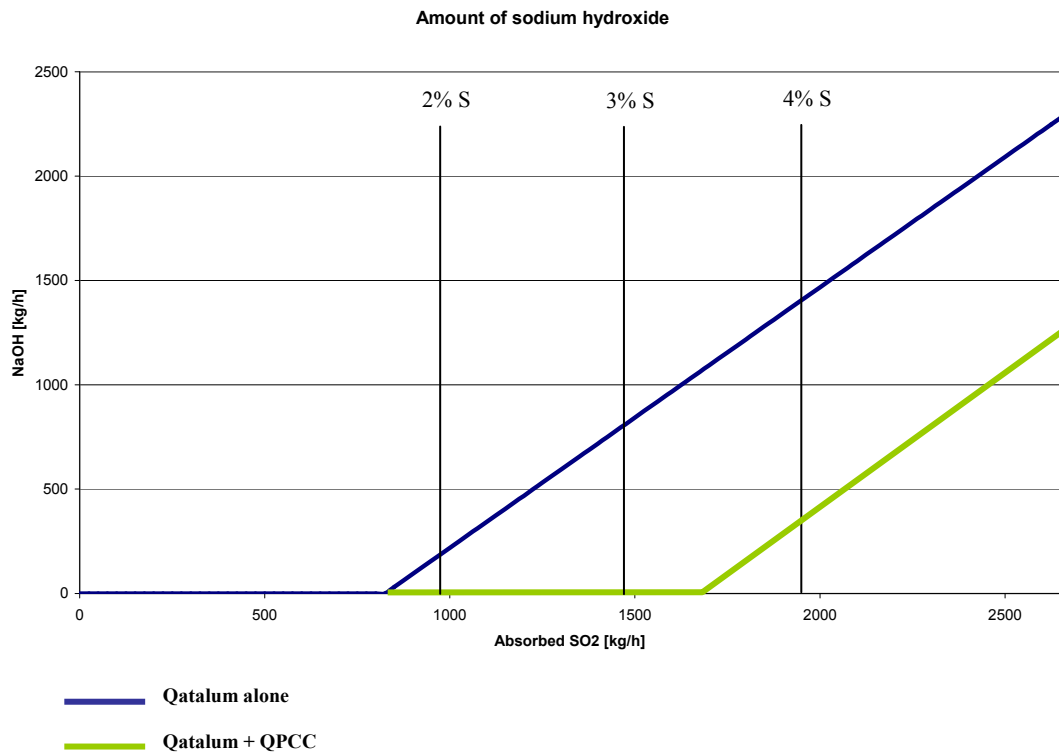

Figure 1. Expected consumption of NaOH depending on SO₂ load according to AEE Lentjes.

2.1.4 Aeration efficiency

AEE Lentjes has designed an aeration system with groups of aerators located along the length of the aeration channel to ensure saturation within each section of the channel. Downstream of each aeration section oxygen will be consumed by the bisulphite and then replenished in the next section of aerators. At the end of the channel all bisulphite has been oxidized to sulphate and the DO will be close to saturation. Figure 2 shows the simulated profiles of bisulphite and DO concentrations along the length of the channel. The simulations were done at 23°C, which is the lowest expected temperature. At higher temperature, the oxidation will be faster.

In the event that used cooling water is available from others (e.g. QPCC) for neutralization, the total flow will increase. This will give lower initial bisulphite concentration, but shorter residence time in the aeration channel. Simulations of this case (Figure 3) show that the bisulphite will be completely oxidized well before the end of the channel, and the water will be >90% saturated with DO.

When Qatalum phase 2 is implemented, the residence time is further reduced, and more bisulphite needs to be oxidized. At this stage, more aeration nozzles will have to be installed. Simulations have been performed to verify that the discharge limit for DO will be met in this case too.

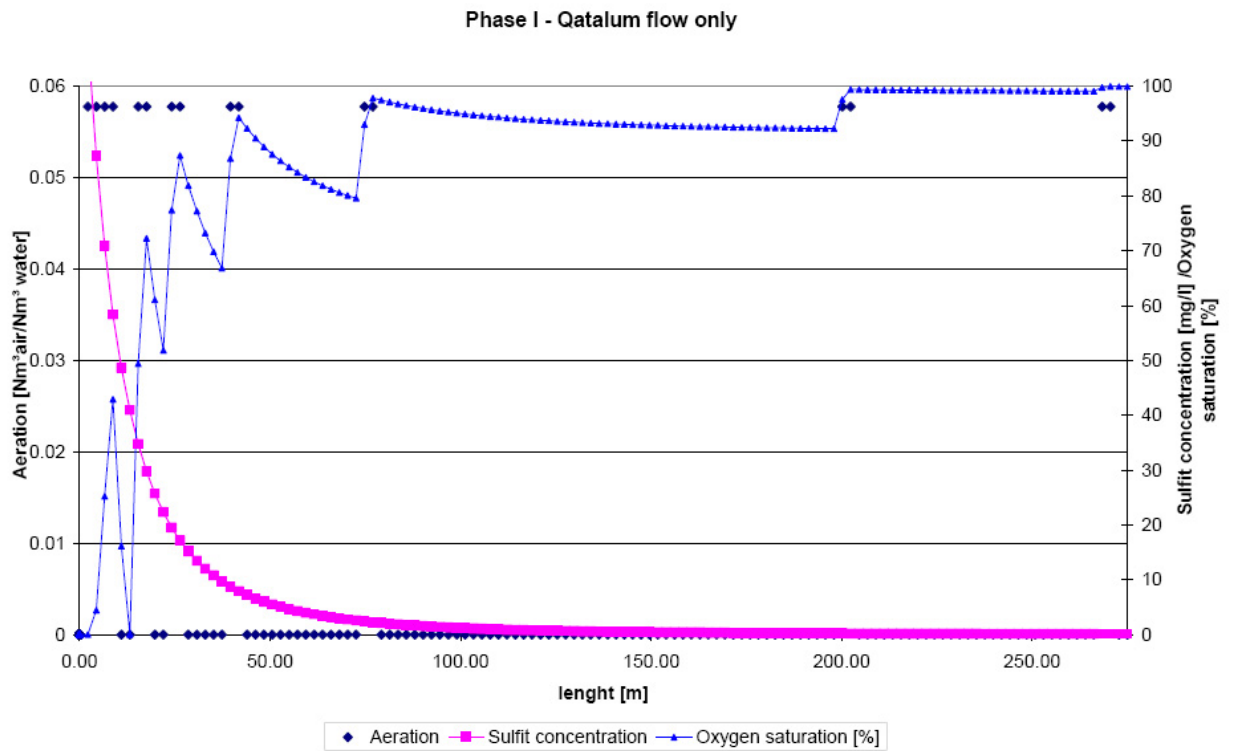

Figure 2 Simulated concentrations of sulphite and oxygen along the length of the aeration channel, Qatalum phase 1 only.

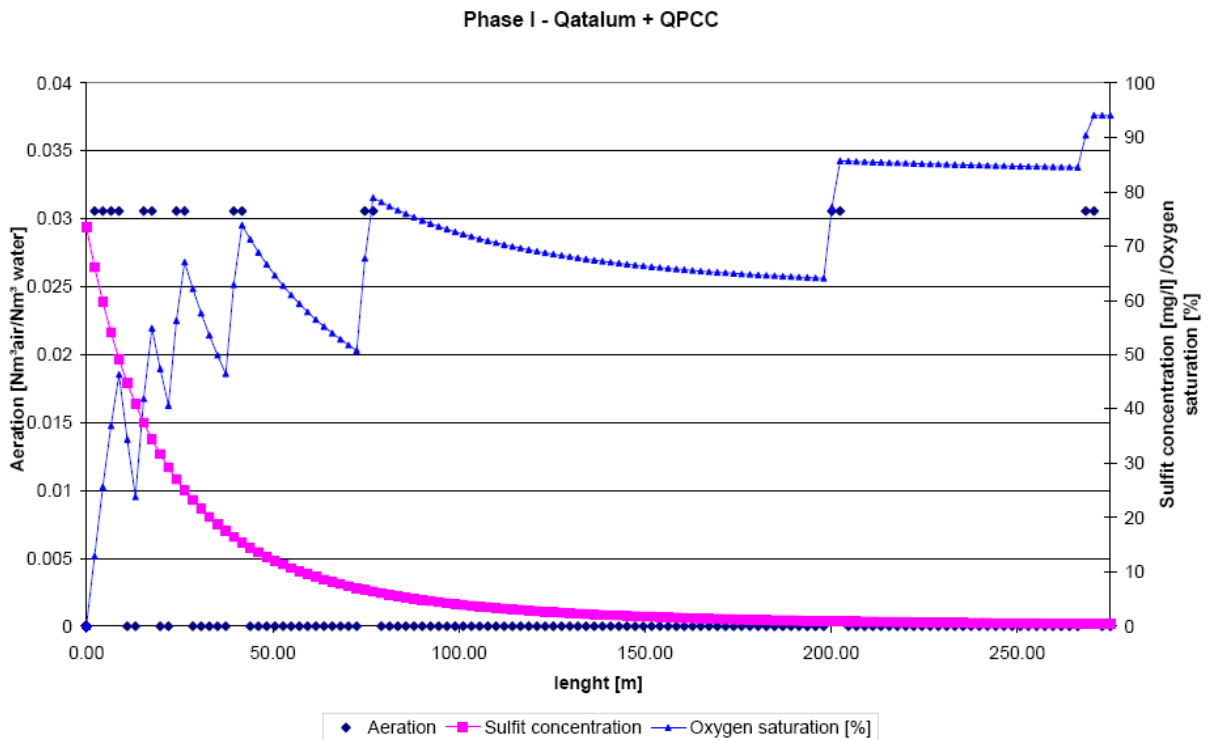

Figure 3. Simulated concentrations of sulphite and oxygen along the length of the aeration channel, Qatalum phase 1 + QPCC.

2.2 Technical description of the treatment facilities

Design drawings of the treatment facilities are shown in Appendix A. Drawing 1 gives an overall process flow diagram and Drawing 2 a situation map. A simplified flow diagram of the process is shown in Figure 4.

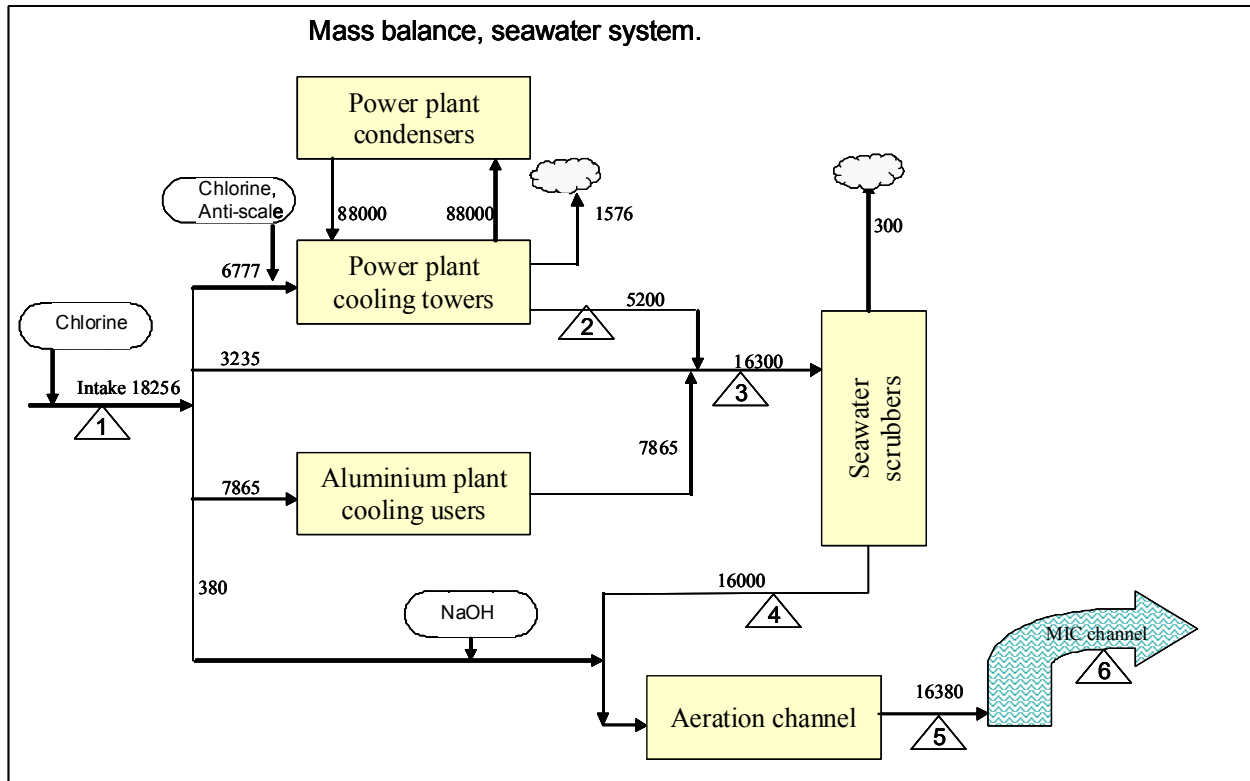

Figure 4. Schematic view of the Qatalum seawater system. All flow rates indicated are in Nm^3/hour .

2.2.1 Scrubber effluent drainage pipes

Scrubber effluents from the four fume treatment plants (FTPs) are collected in two large parallel drainage pipes, which are routed parallel to the potlines towards the southern border of the plant. Before crossing the fence near the roundabout, NaOH is injected into each of the pipes. The pipes continue underground about 300 meters before they enter the aeration channel (see overall arrangement drawing QA-S1-SNL-M56-00200 in Appendix A)

2.2.2 Sodium hydroxide storage

Sodium hydroxide is stored in three 80 m^3 storage tanks close to the southern fence line, and close to the NaOH injection point (Appendix A, Drawing 6). All three tanks are connected to a common header which enables a communication of the tank levels. To keep viscosity of 50% NaOH

sufficiently high the whole system is insulated, tank equipped with a heating coil, and the piping is heat traced to keep the temperature above 29°C. The vent of each storage tank is equipped with a dust filter and a CO₂-filter to prevent the formation of carbonate. The system is designed to receive NaOH in concentrations 32% - 50%. According to the safety requirements all equipment is located in a concrete basin, with a minimum capacity of 1.25 times the volume of all three tanks (3 x 1.25 x 80 m³), with a drainage system and a sump pit with no connection to the outside. The capacity of the storage tanks corresponds to 5.5 days consumption using 50% NaOH at design SO₂ load. NaOH will be supplied by truck from the QVC chlorine-alkali plant in MIC.

2.2.3 Sodium hydroxide injection

Concentrated NaOH solution cannot be dosed directly into the effluent since clogging occurs and intensive mixing would be necessary to raise the seawater pH. Therefore the concentrated solution is diluted with fresh seawater in a static mixer to below 0.1 mol/l (4 g/l) prior to injection into the Qatalum Outfall seawater effluent pipes, upstream of a distribution chamber (Appendix A, Drawing 1). The pH-value of the effluent is monitored at the end of the aeration channel and adjusted by data feedback to the NaOH flow control valve.

2.2.4 Distribution, collection and inlet chambers

The Qatalum seawater outfall effluent is transported via underground piping to a distribution chamber where the flow is distributed into four pipes for even distribution across the width of the aeration channel (Appendix A, Drawing 2). In the following collection chamber, additional seawater effluents from the M-Power Plant and the Petrochemical complex (QPCC) may be added and evenly mixed with the Qatalum seawater effluent flow to the inlet chamber. In the inlet chamber the flow is divided in two equivalent flows for the two halves of the aeration channel, which are separated by a division wall. For maintenance reasons, each half of the channel can be closed by using manual stop logs.

2.2.5 Aeration channel

The aeration channel is a rectangular concrete structure which is 20m wide, 280m long and 3.0 m deep, and divided longitudinally with a concrete wall (Appendix A, Drawing 3). A special pipe system distributes the oxidation air, in accordance to the reaction retention time, in the oxidation zone of the aeration channel. Distribution pipes are arranged horizontally and equipped with plate diffusers arranged in groups along the length of the channel, with the highest density of diffusers near the inlet. The air headers are prepared for attachment of more diffusers when needed for an expansion of Qatalum.

Air is provided by an air blower station with 3 blowers located inside the Qatalum fence, near the NaOH storage tanks (Appendix A, Drawings 4 and 5). The station has acoustic protection to maintain the noise level below 75 dBA at the fence line. Ambient air is filtered by an inlet air filter system and each blower is equipped with its own filter system. The air from the inlet air filter system is partly used for feeding the air distribution system with compressed air and partly used for the cooling of the equipment within the acoustic hood. The capacity allows operation of 2 blowers with one stand-by. The compressor building allows installation of 2 more blowers for later expansion of Qatalum. The operation of the blowers is controlled by the measurement of DO at the end of the channel, so that sufficient air is supplied, without excess use of energy. The air is transported in a large underground pipe to the upper end of the aeration channel. Here the air stream is split in two air headers, each supplying one side of the aeration channel diffusers.

2.2.6 Process control and monitoring

The pH and DO of the treated seawater are measured at the end of the aeration channel. Samples are collected from each aeration channel and mixed together prior to analysis. Measured DO regulates the volume flow of air to the diffusers and the amount of NaOH dosed is adjusted according the pH

measurements. Temperature is also measured and recorded, and the sampling system allows taking samples for other types of analysis.

2.2.7 Discharge channel

Downstream of the aeration channel the two streams are combined and flow over a weir into a trapezoidal channel built in rip-rap with the same design as the existing MIC channel. The rip-rap part of the channel is approximately 240 m long. At the intersection to the MIC channel, the Qatalum channel is widened in an angle to avoid backwater flow towards the Qatar Steel outfall.

2.3 Key design parameters

Design specifications for the scrubber effluent treatment system are given in Table 1.

Table 1. Key design parameters for the scrubber effluent treatment system.

| Parameter | Value | Comments |
|--------------------------------------|---------------------------|---|
| Qatalum phase 1 design flow rate | 18,000 m ³ /h | Normal flow 16,000 m ³ /h |
| Aeration channel design capacity | 77,000 m ³ /h | Allowance for 36,000 m ³ /h from Qatalum and 41,000 m ³ /h from others. |
| Design SO ₂ load, phase 1 | 2000 kg/h | Designed with a margin above design load on scrubbers: 1932 kg/h |
| Average alkalinity | 2.4 meq/l | |
| Temperature range | 23 – 43 °C | |
| Average salinity | 4.7 ‰ | |
| Normal flow of NaOH (32%) | 3.0 m ³ /h | At design SO ₂ load |
| Fresh seawater to static mixer | 380 m ³ /h | |
| Normal air flow | 18,300 Nm ³ /h | |
| Number of aerator plates | 1,280 | 32 clusters with 40 plates in each |

3. Characterization of the marine environment

In the following a short description of the receiving marine environment is given. Most of the information is extracted from an environmental impact assessment made by Atkins (2006) for the Qatalum project compiling all relevant earlier information and from a marine environmental baseline study performed by URS Qatar LCC (URS) in July 2008 which has been made available to NIVA. The latter survey covered physical, chemical and biological characterization of the waters and sediments in the vicinity of the MIC channel. The report from this study also compares to some extent the results with previous surveys.

3.1 Coastal and seabed characteristics

The coastline is strongly modified by the industrial development. At the northern border the industrial development has created a shallow lagoon to the NW. Along the industrial area the natural intertidal biotopes have been replaced by artificially reinforced beaches, sea wall constructions, berths and causeways. The waters are shallow with a depth seldom exceeding 25 m. The bottom along the berths has been dredged to 10-15 m depth for navigation.

The seabed outside the industrial area consists largely of fine sand and silt and with very little clay (URS 2008). In reasonably undisturbed areas the sand content is around 70 %. The finest sediment (20 % sand and also some clay) is found in the dredged areas. To the north and east a thin veneer of sand and shell fragments lies on top of limestone bedrock. The coastline seem stable and shows no signs of erosion or littoral drift.

URS (2008) found that the total content of organic matter (TOC) in the sediments varied between 5 and 18 % which is on the high side compared to coastal sandy sediments in general. On the other side Atkins (2006) recorded TOC levels generally < 1 %, which is more typical for sandy sediments. The discrepancy may be due to differences in analytical procedures.

3.2 Currents waves and tide

The URS survey included continuous logging of tide and current measurement from 13/07/2008 to 11/08/2008. During this period the spring tidal range was around 2.58 m and the neap tidal range around 0.49 m. In general it has been reported that mean spring tidal range is 1,5 m (Atkins 2006). These data show that the coastline faces a moderately large tidal fluctuation.

Wave height seldom exceeds 1 m. Seasonal wind may generate wave heights of around 1.5 m, but only for 5-10 % of the time.

The URS current measurements in 2008 were done by use of an Aanderaa ADCP moored in a position about 500 m east of the Qatar Steel Berth. The water depth at the site was 8 m. Both surface (-1 m), mid depth (- 4 m), and bottom (- 7 m) current velocity were in the range 0.03 - 0.61 m/s. At surface and mid depth the current direction fluctuated predominantly between 100° and 300° probably influenced by prevailing wind direction (W to E), whereas the bottom current had a slightly different direction predominant 10° and 260°, apparently more influenced by the coast. Atkins (2006) reported similar current velocities generally in the range 0,05 – 0,25 m/s.

3.3 Hydrographical conditions

During the URS survey in July the natural water temperature outside the industrial site varied in the range 32 – 34 °C. There was an increase in temperature towards the surface, a stratification which is typical during late summer. In general for the Qatar region the lowest temperature around 20-22 °C is experienced during January-February, and highest 35-37 °C during July-September (Figure 5).

Salinity is generally in the range 40-50 PSU in Qatar waters. During the URS campaign salinity ranged from 41,5 to 47,4 PSU. Slightly elevated salinity near the surface at several stations is explained by high evaporation in combination with the thermal stratification. These levels are relatively normal for the time of the year in which they were recorded.

In the URS survey the level of suspended solids (TSS) ranged from 2 to 15 mg/l, mostly <10 mg/l. This is typical for many coastal water bodies, although TSS may vary considerably due to e.g. phytoplankton blooms, resuspension of sediments and runoff from land.

Figure 5.3 – Seawater Temperature (QAFCO data)

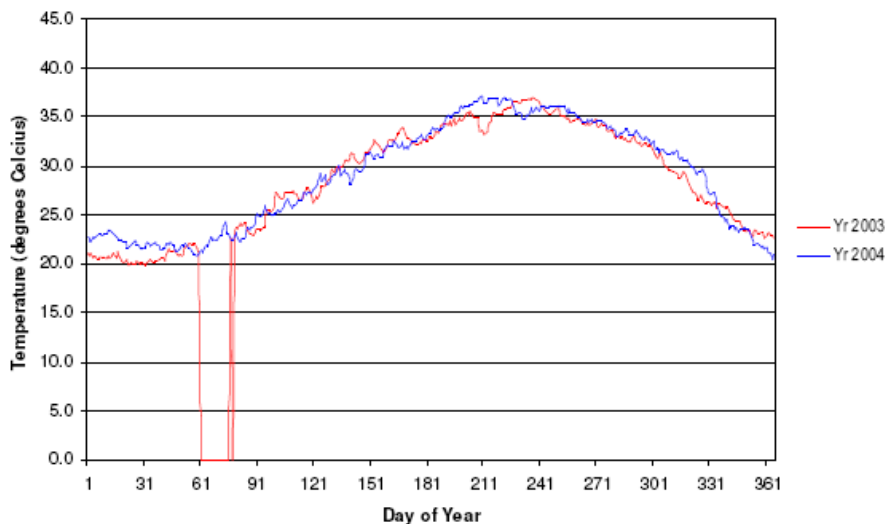

Figure 5. Annual seawater temperature fluctuation near the Qatalum site (from Atkins 2006).

Levels of DO in the local surface waters are in general in the range 5 – 7 mg/l (86 – 121 % saturation). Apart from one site inside the MIC channel with DO of 4,5 – 5 mg/l and a few recordings deeper than 10 m of DO around 5 mg/l, all URS survey measurements were in the range 5,5 – 6,5 mg/l. The DO had a maximum at around 2-3 m depth with supersaturation in the range 112-122 %. Deeper than that DO declined gradually, but even close to the bottom the saturation was never below 90 %, which shows good water exchange in the area presumably due to the shallow water depth. No indication of oxygen depletion has been reported.

Chemical oxygen demand (COD) was generally around 100 mg/l in all water bodies during the URS survey even at the reference station. Corresponding COD measurements made by MIC in 2007 gave an average of only 36 (± 32 SD) mg/l in 50 water samples from the same region. This discrepancy is probably due to the difficulty of measuring COD reliably in highly saline water due to chloride

interference. Disregarding this, any local COD is apparently not having an influence on the DO levels, hence the material representing the potential COD is not easily degraded.

The pH levels in the water sampled by URS in July 2008 ranged from 7,0 to 8,0 which is low compared to the natural range 7,5 – 8,5 in fully saline seawater. It is also below the range measured in two previous surveys in the Mesaieed area being 8,19 – 8,41 and 7,88 – 8,85. URS explains the difference to be due to seasonal variability. However, monthly readings at 3 stations outside MIC in 2006 and 2007 showed low variability: from 8,0 to 8,3 (MIC Environmental Report). Also the local seawater samples used by ESC in the neutralization and dilution experiments presented in Annex C had a pH range of 8,24 – 8,31. Since there are various ways of scaling pH (e.g. NSB, NIST or Total) and the URS report does not specify how this was done, we have concluded that the typical local seawater pH is in the range 7,9 – 8,3.

Atkins (2006) reported local levels of total suspended solids (TSS) in the range 1 – 8 mg/l. Slightly higher range 2 – 16 mg/l was recorded by URS on July 2008. The waters are considered uncontaminated with inorganic nutrients (i.e. no eutrophication).

3.4 Biological characteristics

The biological communities within the Arabian Gulf waters are typically low in biodiversity and abundance mainly due to the harsh conditions of temperature and salinity. In particular the temperature fluctuation is an important stress factor. The local marine communities are not deviating from this picture. In the dredged navigational channel outside the berths the visible flora and fauna is very sparse, being considerably richer and with more undisturbed seagrass communities in the shallow area east of the channel.

Fish nurseries, turtles and marine mammals have not been observed in the area, and the occurrence of fish (mainly gobies) is sparse.

3.4.1 Pelagic ecology

Two parameters indicating the status of the local pelagic communities were included in the URS study: chlorophyll *a* (Chl *a*) as a measure of phytoplankton biomass, and zooplankton densities and diversity.

There was a tendency of increasing levels of Chl *a* with water depth. Since light is probably no limiting factor with depth in these shallow waters this is presumably regulated by higher levels of inorganic nutrients near the bottom and possibly UV-light inhibition of phytoplankton growth near the surface. Chl *a* showed no systematic change with distance from land. In general there seems to be no clear seasonal trends in Chl *a* yet recorded for the Arabian Gulf or Qatari waters.

The crustacean group Copepoda including juvenile copepodites dominated the zooplankton at all stations (35-65%). The most common species were *Paracalanus parvus* and *Acartia cf pacifica*. Predominance of copepods is typical for most zooplankton communities. Gastropod larvae were also frequent in the samples showing a strong influence of larvae of benthic fauna (possibly from the seagrass beds) at this time of the year. Overall zooplankton diversity was high at all stations and the community structure very uniform. The overall range in abundance (8,533 – 38,525 individuals per haul) compares well with other studies in the Gulf using similar net size.

We have found no other description of the pelagic communities in the area or information on fish stocks. To our knowledge no commercial fisheries of any importance are performed in the area.

3.4.2 Benthic ecology

Atkins (2006) describes the benthic ecology at 23 sites in the lagoon and shallow subtidal bottoms to the NE of the industrial site on basis of SCUBA diver surveys, and also reports on earlier similar studies. The local marine benthic habitat types may be classified into 4 groups, all typical of the southern Arabic Gulf region.

- Fine open sand with a range of typical infauna (polychaetes, molluscs, crustaceans, pennatulaceans).
- Coarse sand and shell/rock fragments with sparsely scattered epifauna (sponges, ahermatypical corals, molluscs and ophiuroids).
- Mixed epibenthic community on bedrock, dominated by molluscs, gorgonians, and various types of coral species, reflecting the occasional periods of reasonably high current velocity.
- Seagrass beds with up to 100 % cover by 3 different *Halophila* species.

The species richness of macrofauna ranged from 1 to 19 species per station across the 23 Atkins stations, the poorest sites being in the lagoon area. The URS study, analysing sediment macrofauna (> 0,5 mm) at 9 stations sampled in triplicate by either bottom grab or scooped up from within a frame by divers, gave a similar macrofauna richness: 1-22 species per station. Number of species and biodiversity (Shannon-Wiener index) in the URS study was considered high compared to an earlier corresponding survey at Abu Harmour, but seem not to deviate from the typical range for near shore sediments in this region. Apart from the poor lagoon there was no clear local spatial pattern in diversity or in overall similarity of fauna structure among the stations, other than the northern stations being slightly poorer than the southern. This is explained by differences in sediment characteristics.

Sediment species composition showed a typical pattern with dominance of polychaete worms followed by crustaceans, molluscs (gastropods and bivalves), and sipunculid worms. The seagrass beds were dominated by epifauna such as gastropods, ascidians (sea squirts) and sponges.

3.5 Ecological elements of concern

The marine biotopes of particular concern in the area are the seagrass beds. These are most dense at the 2-6 m depth range, with lower depth distribution limited by the seasonal turbidity. Atkins recorded the densest seagrass beds to the north of the industrial site outside the lagoon. These beds support high productivity and species diversity. According to Hydro there are no seagrass beds closer to the MIC channel outlet point than about 500 m due to earlier bottom sediment dredging to obtain a harbour depth of about 10 m. Also Atkins (2006) states that there are no known significant or sensitive habitats within 500 m of the channel discharge point. However, both Atkins and URS recorded sea grass occurrence in or close to the dredged area, but only scattered sea grass plants. We have received no other registration of important, environmentally sensitive, or protected areas in the vicinity of the industrial site.

3.6 Pollution status

Atkins (2006) presents data on total hydrocarbons, heavy metals and PCB in the local sediments. The URS study from July 2008 covers analysis of selected heavy metals and organic contaminants in water and sediments across the dredged area outside the industrial berths. These are the only sets of data being available to us. They are briefly outlined below.

3.6.1 Sea water

Heavy metals

A range of metals have been analysed from the water samples by URS. Levels of chromium, cadmium, copper, lead, zinc, iron, manganese, and cobalt, could be quantified, and were all well within the standards given by the Qatar MoE. They also correspond to the background range for Norwegian coastal waters. No traces of arsenic, nickel, vanadium, selenium, mercury or tin were detected.

BTEX (Benzene, Toluene, Ethylbenzene, and Xylene) and PAH₁₆ (polyaromatic hydrocarbons)

The levels of all these aromatic hydrocarbon compounds were below a satisfactory analytical limit of detection (LoD = 0,01 µg/l) in all samples and hence considered to be of no environmental concern.

PCBs

Atkins (2006) refers to an earlier study detecting 1,7 and 2,5 µg/l of PCB (as Arochlor 1254) in the surface waters, suggesting some risk to higher marine life through bioaccumulation. We have no other data that substantiate this.

Oil and grease

The levels of oil and grease were in the range 2 – 34 mg/l, the lowest value seen at the reference station. Several samples exceeded the water quality guideline of 10 mg/l given by the MoE. Atkins (2006) on the other hand reported TPH (total petroleum hydrocarbons) levels from 0,07 to 0,66 mg/l (average 0,2 mg/l). In comparison with background levels in the Gulf of 0,0004 – 0,006 mg/l they characterised the waters as clearly oil contaminated probably from many sources. Since the gravimetric method used by URS (SM 5520B) is not sufficiently sensitive to measure hydrocarbons reliably in recipient seawater, we would put most emphasis on the Atkins data.

Free residual chlorine (FRC)

Chlorine may enter the recipient with cooling water discharges since chlorine is used as anti-fouling agent in most seawater cooling water systems. FRC does not occur naturally in seawater, but in the URS survey levels from 0 to 0,25 mg/l (average 0,07 mg/l) were found, which is somewhat surprising. There was no apparent spatial pattern that could link the ambient FRC levels directly to the existing cooling water outlet from the MIC channel (both the reference site and the site closest to the outlet had no chlorine), but this may be due to the highly dynamic current pattern in the area. Available information does not suggest any other local source for FRC.

3.6.2 Surface sediments

Heavy metals

Atkins (2006) refers to other studies showing occasional slight elevation in sediment levels of iron, lead, mercury, nickel, cobalt, cadmium, and zinc, but not chromium or copper. The same range of metals was analysed by URS. Apart from zinc and vanadium the levels were equal to or lower than recorded in previous studies. The metal levels showed no spatial pattern.

Total petroleum hydrocarbons (TPH)

Levels of TPH are given as µg/kg in the URS report, which is probably a misprint for mg/kg considering the likely LoD for the method used (GC/FID). Still the levels encountered seemed to be within the typical background range for marine sediments (<10 mg/kg) and with no clear spatial pattern except that the lowest level was found at the reference site. Earlier studies referred to by Atkins (2006) showed some sporadically high levels of TPH (140 mg/kg), but generally much lower (<5 mg/kg), and concluded that the distribution of TPH was very patchy.

PAH and PCB (polychlorinated biphenyls)

None of the sediment samples analysed by URS had levels of PAH or PCB above the reported LoD (0,01 µg/kg). This is too low for harbour sediments to be realistic and also far below what is normally encountered in offshore sandy sediments (around 40 µg/kg). One explanation may be that the notation should read mg/kg here as well.

Radio isotopes

Samples from 4 stations were screened for alpha, beta, and gamma radiation without finding levels exceeding background levels with the exception of U238 exceeding a referred standard slightly. This was thought to be due to proximity to the Gabbro berth since the gabbro mineral is known to be enriched in several radioactive elements including U238.

4. Environmental impact evaluation principle

The principle adopted for the impact assessment is a typical PEC/PNEC approach. This compares Predicted Environmental Concentrations (PEC) of each discharge component with a Potential No Effects Concentration (PNEC) of the same component to determine the spatial extent of an environmental impact zone in the recipient. An impact zone is defined as the area or water volume where PEC exceeds PNEC, resulting in a ratio $PEC/PNEC > 1$ (Figure 6). Under such condition there will be a risk of environmental effects from that component. The overall impact zone will correspond to the maximum impact zone of individual components. The size of the impact zone will have to be evaluated against either agreed acceptance criteria or presence of particularly valuable ecological units (e.g. protected biotopes or species) to assess if the impact of the discharge is acceptable or not to the authorities/public.

There is always an uncertainty linked to the establishment of PEC and PNEC values for a given situation. The PEC is dependent on the reliability of the ambient dispersion and dilution modelling of the discharge plume. The PNEC is a global entity for each component derived from toxicity data and with safety application factors to account for lack of such data. This implies that the PNEC is stricter for compounds for which there are little toxicity data. Where there is a range in likely values for these entities, we have taken a conservative approach by choosing PEC values on the high side and PNEC values on the strict side. This is to ensure that we do not conclude wrongly that the $PEC/PNEC$ ratio is below 1, and hence underestimate the extent of an impact zone.

A PEC/PNEC approach is only possible for compounds where it is safe to apply a PNEC which is above the ambient level of that compound. If not a $PEC/PNEC < 1$ will never be reached. However, it is reasonable to assume that the local organisms in question are able to tolerate some fluctuation in the ambient levels, especially in shallow water where the organisms must be adapted to varying environmental conditions in general.

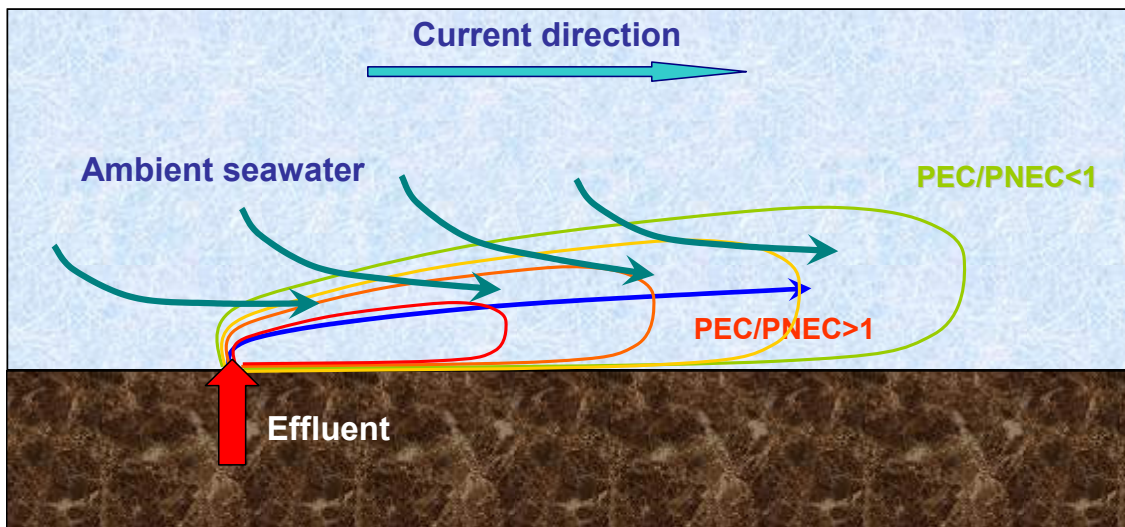

Figure 6. Schematic “bird’s eye” view of the ambient dispersion/dilution and PEC/PNEC pattern of an effluent plume. The limit of the impact zone is indicated by the green outline.

5. Environmental quality standards

5.1 Derivation of environmental quality standards (EQS) values

We have defined PNEC values necessary for a PEC/PNEC impact assessment (cf Chapter 4) as equivalent with environmental quality standards (EQS). The EQS of a compound is the concentration below which there is no risk of environmental effects from chronic exposure, hence this equals the PNEC. We have generated EQS values for the effluent parameters on basis of several sources (in order of priority):

- Specific EQS values requested from the MoE for the present assessment
- Ratified or proposed national EQS values for Qatar
- Internationally agreed EQS values
- Other national EQS values
- EQS values developed for the present purpose on basis of scientific literature.

It is emphasised that the EQS values used in this assessment are either representative for tropical waters in general or universally valid. There is no empirical basis that enables EQS values to be generated specifically for the local marine recipient outside Qatalum. The proposed EQS values are, however, conservative in order to safeguard the marine environment in general from chronic exposure. They should therefore also safeguard the marine life outside Qatalum even at the most sensitive season of the year as required by the MoE. Chronic exposure is relevant for the typical operational Case 1A. The other cases are expected to last for shorter periods, and hence EQS values for acute exposure would be more appropriate (normally based on 48 to 96 hour exposure tests). Acute EQS values should in principle be higher than for chronic exposure since organisms are expected to tolerate higher exposure for shorter periods of time, but have only in rare cases been developed. We have therefore taken the conservative approach of using chronic EQS values in all cases.

5.2 EQS for factors of environmental concern

Based on the reactions described in Chapter 2 the main factors of environmental concern directly influenced by the change in water quality from wet scrubbing are pH, alkalinity, DO, and residual sulphide expressed as COD. Additional factors of concern due to the cooling water use are temperature, FRC as antifouling agent, and scale inhibitor. The requirements given by the Qatari MoE for the Qatalum environmental studies state that also sodium (Na^+ from NaOH neutralization), sulphate (SO_4^{2-}) and sulphide (S^{2-}) are to be assessed. In this chapter the EQS or PNEC values used in the environmental assessment are derived.

5.2.1 Temperature

Discharge of cooling water with elevated temperature may cause stress to the organisms in the recipient. For tropical regions the danger of exceeding the upper tolerance limits is most relevant since many organisms already live close to this limit. There are no agreed international EQS for overtemperature, but certain countries have set national standards. The strictest standard has been set by the US EPA for marine tropical regions of +1°C above ambient, and the European Community for designated fishing grounds at +1,5°C above ambient. In Venezuela an Effluent Quality Decree states an EQS of +3°C for Venezuelan waters. Also the Qatar regulations set an EQS for overtemperature in cooling water at +3 °C. This standard is also recommended by the World Bank. An EQS of +3°C above ambient is therefore used as the target PNEC in the present assessment.

Figure 7 gives the necessary dilution of an effluent with ambient water to obtain an overtemperature less than an EQS ranging from 0,5°C to 3°C, and for a temperature increase (ΔT) in the effluent

varying from 2 to 10 °C. This is the relevant ΔT range in the present situation (maximum 8,2 °C, cf Table 4 - Table 6). The figure shows e.g. that even with a ΔT as high as 10 °C in the effluent only 3 times ambient dilution is required to comply with a PNEC of +3 °C.

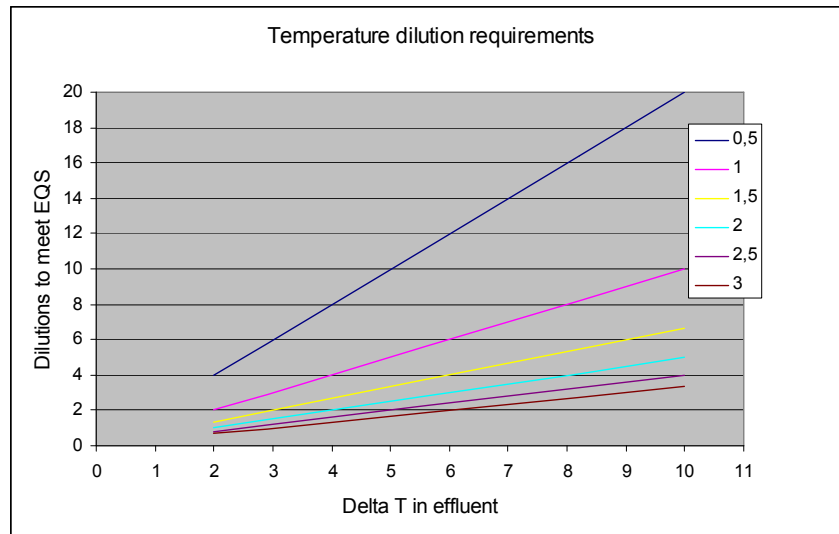

Figure 7. Dilution factors required to meet various EQS values for overtemperature (from 0,5 to 3 °C) as function of ΔT in effluent.

5.2.2 pH

Current research indicates that impact of seawater acidification on marine organisms will largely be negative, and the impacts may differ from one life stage to another. There may be interactions between CO₂ hypersaturation, temperature, and other stressors which are not fully understood. Reduction in pH (ocean acidification) is forecasted to reduce calcification rates in corals as well as economically important shellfish species such as oysters, scallops, mussels, clams, sea urchins, crabs, and lobsters, but to what degree this may be caused by the decreased pH alone or is a direct effect of increase in dissolved CO₂ causing pH reduction, is not clear, nor is how this may affect marine biodiversity in general (Widdicombe and Spicer 2008). Apart from gastropods and bivalves none of ‘calcifying’ types of organisms are important in the ecosystem outside MIC.

Table 2 shows some national EQS values for pH. The Qatari seawater quality standard is in line with these, defining a lower EQS value of 6,5. US EPA's current recommended criterion for marine pH states: pH range of 6.5 to 8.5 for marine aquatic life (but not varying more than 0.2 units outside of the normally occurring range). Review of literature on pH tolerance indicates that there is little evidence of harm to marine organisms from a decrease of 0,5 – 1 pH units from ambient (Knutzen 1981). It is also suggested that marine organisms are more sensitive to a rise in pH than a decrease (Wolff et al 1988). The majority of the effects observed in laboratory studies have occurred at pH levels beyond the USEPA allowed variability of 0.2 units, only one study describing effects at pH changes of less than 0.2 units (sublethal effect on squid metabolism). Considering also the fact that natural pH in marine waters may fluctuate considerably over time at one site (cf Figure 8) in spite of the buffering capacity of seawater it is reasonable that the impact analysis applies the Qatar EQS of 6,5. We have however also included an assessment of the impact zone necessary to comply to the EPA conservative criterion which will give an EQS of $7,9 - 0,2 = 7,7$.

Table 2. Examples of national environmental quality standards (EQS) for pH in marine waters (From Wolfe et al 1988).

| Source | EQS value |
|---|--------------|
| US EPA | 6,5 – 8,5 1) |
| Australia | 6,5 – 8,5 |
| China | 7,5 – 8,3 |
| Japan | 7,8 – 8,3 |
| Qatar | 6,5 – 8,3 |
| UK Water Research Centre, protection of shellfish | 7,0 – 8,5 |
| UK Water Research Centre, protection of fish | 6,0 – 8,5 |

1) but not more than 0,2 units outside normally occurring range.

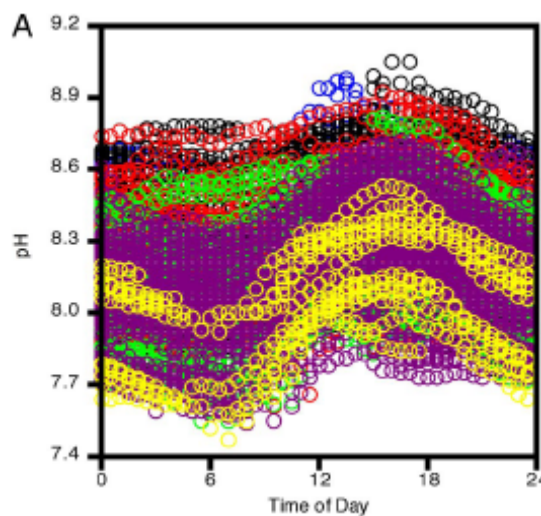

Figure 8. Daily cycle of seawater pH at Tattosh Island (48.32°N, 124.74°W) arising from primary production at various months of the year (indicated by color). From Wootton et al. (2008).

5.2.3 Dissolved oxygen (DO)

Oxygen is necessary for all plant and animals. Tolerance to reduced DO varies greatly in different parts of the marine environment. Organisms which normally live in oxygenated water, e.g. close to the surface, and with high activity such as fish, are most vulnerable. Sediment living organisms may tolerate very low levels for long periods of time. In general oxygen levels above 4,8 mg/l are considered safe to marine life in temperate regions, and below 2,7 mg/l to be critical (Bakke et al 2002). Bull et al. (1982) consider organisms in tropical waters to be stressed at DO < 4 mg/l. The Qatar seawater quality standard for DO is also 4 mg/l. The typical shallow water range in DO locally is 5,5 – 6,5 mg/l (Chapter 3.3). On basis of the above we consider an EQS of 4,5 mgDO/l to be sufficiently conservative in the present assessment. However, in compliance to a request from MoE an EQS of 5 mg/l has also been included in the assessment. This may however be too conservative being within the normal ambient range outside Qatalum (cf Chapter 3.3).

5.2.4 Sulphite as chemical oxygen demand (COD)

The potential impact of sulphite from the seawater scrubbing at Qatalum is not due to sulphite toxicity but to the effect that oxidation to sulphate may have on the DO level. Chemical oxygen demand (COD) expresses the amount of oxygen required to oxidize all compounds in the seawater that can be

chemically oxidised by reaction with the DO. It shows the potential for oxidation, not what is really oxidised. As shown in Chapter 3.3 an ambient COD of 100 mgDO/l has been found outside Qatalum. Many countries have discharge limits for COD mostly in the range 100 – 150 mgDO/l, (Bakke et al 2002). The Qatar regulations, Annex 4,1 states a limit of 100 mg/l for discharges into water bodies. We have not for any country found any established EQS values. This is reasonable since COD in itself is not an environmental factor of concern, only how the oxidation of the COD may influence the DO. The assessment evaluates to what extent the COD due to the sulphite may prevent that the EQS for DO is achieved and in compliance with requirement from the MoE we have applied a zero EQS for this.

5.2.5 Free residual chlorine (FRC)

To prevent biofouling in cooling water systems the inlet seawater is normally injected with hypochlorite produced by electro-chlorination, so also at the Qatalum plant. A total chlorine analyzer makes sure the total residual chlorine is kept between 0.1 – 0.5 mg/l in the seawater distribution network. Additional chlorine is added to the power plant cooling seawater (max 0.15 – 0.3 mg/l) as the water here is re-circulated in the cooling towers.

Frequently there will be an excess of chlorine relative to what is needed in the antifouling process and the effluent may therefore contain FRC. As mentioned earlier Qatari regulations include discharge standards for FRC in cooling water (0,05 mgCl₂/l), but no EQS. We have not found any national EQS value for FRC in other countries. We have therefore defined an EQS value on basis of ecotoxicological literature. Appendix-table A shows some of the representative data from marine species used as basis. The most sensitive organisms appear to be phytoplankton and fish which have NOEC¹ around 0,01 – 0,02 mgCl₂/l. For benthic organisms there is little information on NOECs, but the available literature gives LC₅₀ values from 0,1 mgCl₂/l and upwards. For tropical biofouling mussels sublethal effects may take place at levels below 0,25 mgCl₂/l (Rajagopal et al. 2003).

In risk assessment guidelines established by the European Union (EU 2003) an application factor of 10 should be used on the chronic NOEC from the literature, which would give an EQS of 0,001 mgCl₂/l. However, the half life of FRC in water, especially in tropical waters, is relatively short, ranging from less than an hour to a few days (CEPA 1988), hence chronic effects on fish and phytoplankton moving with the waters are unlikely. Also benthic organisms, which are those that will have to endure FRC exposure for longer periods of time, are apparently somewhat more tolerant than phytoplankton and fish. We therefore consider it safe to use 0,01 mgCl₂/l as the EQS for the present assessment. With an average ambient FRC level of 0,07 mgCl₂/l, the target PNEC will be 0,08 mgCl₂/l (Table 8).

5.2.6 Scale inhibitor

There is a risk that gypsum (CaSO₄) and calcite (CaCO₃) may precipitate to form scale in the system upstream of the scrubber units, in particular in the power plant cooling towers (NALCO in Hydro 2010), but mass balance calculations conclude that there is little risk of this happening in or downstream of the scrubber. The risk of upstream scale formation calls for anti scaling treatment to be implemented. The recommended means is to use Depositrol BL5301, supplied by GE Water & Process Technologies, which is an aqueous acidic solution of phosphonates and polymer. The product is not classified as dangerous to the environment (GE Infrastructure 2008). The active agents are two phosphonic acids (CAS no 2809-21-4 and 13598-36-2) which are also used in a range of household cleaning products. Biodegradation tests of phosphonates have shown the compounds to be moderately degradable, but stimulated by sunlight (HERA 2004). HERA (2004) summarises the available chronic toxicity tests into typical PNEC values ranging from 0,1 to 2,3 mg/l (average 1 mg/l) for the various compounds.

¹ No Observed Effects Concentration: the highest concentration showing no short or long term effects in relevant ecotoxicological studies.

5.2.7 Other components

Sodium ions

The neutralization with NaOH will contribute with sodium (Na⁺) ions to the recipient. Evaporation in the cooling tower and scrubber will also increase the concentration of Na⁺ somewhat. Hence the effluent will be slightly enriched in Na⁺ when discharged. Na⁺ is one of the major elements of seawater. No universal EQS values can be defined for Na⁺, since the tolerance is dependent on the salinity range that varies from a few PSU in brackish water to more than 40 PSU in tropical waters. Temporal salinity variation is a stronger environmental stressor than salinity level itself. Lowest tolerance to variation is found where the natural salinity variation is low.

Sulphate ions

As shown in chapter 2.1.2 the scrubber process produces sulphate (SO₄²⁻) ions that follow the effluent. Sulphate is also a natural element in seawater, and contributes to 7.7 % of the total seawater salinity. Hence the concentration varies proportionally with the salinity. There are no toxicological data that can be used to establish an EQS for SO₄²⁻.

Sulphide ions

The scrubber process may theoretically generate sulphide ions (S²⁻) in absence of oxygen. Sulphide as H₂S occurs naturally in the marine ecosystem, but is extremely toxic to all aquatic organisms except for certain strains of bacteria. However, sulphide will only be present in seawater where there is no DO and hence no organisms apart for anaerobic microbes, and derivation of an EQS is thus irrelevant

Alkalinity

There are no data on toxicity of alkalinity itself in seawater and an EQS cannot be established.

5.3 EQS values applied

Table 3 summarizes the EQS values used in the present assessment

Table 3. EQS values used in the impact assessment.

| Parameter: | EQS = PNEC |
|-----------------------------------|------------------------------|
| Overtemperature | +3°C |
| pH | 6,5 (7,7) |
| DO | 4,5 (5,0) mg/l |
| Sulphite expressed as COD | 0,0 mg/l |
| Residual chlorine (FRC) | 0,08 mg/l |
| Scale inhibitor Depositrol BL5301 | 0,1 – 2,3 mg/l ¹⁾ |

¹⁾ Depending on phosphonate composition

6. Operational cases

The revised EIA covers 3 operational cases for the scrubber effluent treatment described in the SoW:

Case 1: Normal operation with NaOH neutralization giving an effluent with pH=6, DO¹=2 mg/l, and COD=0 mg/l at the outlet from the aeration basin.

This is the base case where the scrubber effluent is neutralized with NaOH prior to aeration. At the end of the aeration channel the effluent has pH = 6, DO = 2 mg/l, and COD = 0 mg/l. It is then mixed with cooling water effluents from Qatar Steel in the MIC channel before discharge to the sea. Further dilution will take place in the sea. This is identified as Case 1A.

The evaluation also covers a Case 1B which is an exceptional situation where the NaOH neutralized Qatalum effluent is aerated and discharged through the MIC channel to the sea alone. The situation may arise if the Qatar Steel effluent is not available in the channel for some reason (e.g. maintenance shut-down). According to information from Qatar Steel a planned shut-down occurs for 1 day every year. In addition unplanned shut-downs may occur. It is anticipated that these events will last for short periods only. The physical and chemical characteristics of the effluent entering the sea from Case 1A and 1B are given in Table 4.

Table 4. Physical and chemical characteristics of the effluent to the sea in Subcase 1A (combined Qatalum and Qatar Steel effluents entering the sea) and Subcase 1B (Qatalum effluent entering the sea alone), and EQS values applied. n.a.: not applicable.

| Parameter: | Level in Qatalum effluent (Case 1B) | Level in Qatar Steel effluent | Level in combined effluent (Case 1A) | EQS = PNEC applied |
|--|-------------------------------------|-------------------------------|--------------------------------------|--------------------|
| Flow rate | 16 380 m ³ /h | 44 000 m ³ /h | 60 380 m ³ /h | n.a. |
| Temperature (min – max) | 27 – 43 °C | 26 – 42 °C | 26 – 42 °C | n.a. |
| Overtemperature relative to ambient (ΔT) | 2,9 – 8,2 °C 1) | 5,6 °C | 4,9 – 6,3 °C | +3 °C |
| Salinity | 47 PSU | 47 PSU | 47 PSU | n.a. |
| pH | 6,0 | 8,2 | 7,2 - 8,0 7) | 6,5 (7,7) |
| Alkalinity | 0,0 meq/l 2) | 2,4 meq/l | 1,8 meq/l | n.a. |
| Dissolved oxygen (DO) | 4,0 mg/l 3) | 5,0 mg/l | 4,7 mg/l | 4,5 (5,0) mg/l |
| Sulphite expressed as COD | 0,0 mg/l | 0,0 mg/l | 0,0 mg/l | 0,0 mg/l |
| Net sulphate produced from wet scrubbing | 182 mg/l | 0 mg/l | 49 mg/l | n.a. |
| Total sulphate in effluent 4) | 4216 mg/l | 3550 mg/l 5) | 3731 mg/l | n.a. |
| Residual chlorine (FRC) | 0,0 mgCl ₂ /l 6) | < 0,1 mgCl ₂ /l | <0,07 mgCl ₂ /l | 0,08 mg/l |

1) From Qatalum EIA, Table 6.5

2) All alkalinity is consumed in the scrubber

3) According to CtO conditions

4) When natural sulphate from intake seawater is included

5) Assuming no evaporation in Qatar Steel condensers

6) According to Hydro (2010).

7) Based on the experimental results for pH change during dilution with seawater of a simulated scrubber effluent having pH=6 after neutralization with seawater and with purging. The value 7,2 is from the NIVA trials, 8,0 from the ESC trials.

¹ Dissolved oxygen

Case 2: As Case 1A, but with failure of NaOH neutralization giving an effluent with pH-conditions as described from the ESC experiments, DO= 0 mg/l, and COD= 25,3 mg/l.

In this case the 16,000 m³/h Qatalum effluent will go directly to aeration without any treatment with NaOH. The effluent entering the MIC channel will have a pH as described from the ESC experiments (Appendix C), DO = 0 mg/l, and COD = 25,3 mg/l. In the MIC channel it will be mixed with Qatar Steel cooling water prior to discharge to the sea.

Case 2 is not strictly covered by the NIVA (Appendix B) or ESC (Appendix C) experiments. The best simulation of what happens in the MIC channel in Case 2 is a combination of the experiment where the scrubber effluent of pH=3 was neutralised with seawater without air purging and the experiment with subsequent dilution of this mixture with additional seawater. The first experiment showed that 185 ml seawater were needed to raise 300 ml of test effluent from pH=3 to pH=6. In proportion to this the processing of 16 000 m³/h of Qatalum effluent demands 9 900 m³/h of the Qatar steel water. This leaves 34 100 m³/h for the subsequent dilution giving in a dilution factor of $34100/(16000+9900) = 1,3$. According to the ESC results from the second experiment such dilution will raise the pH from 6 to 8,02, which will then be the overall pH at discharge to the sea. From the corresponding NIVA experiment a dilution factor of 1,3 results in a somewhat lower end pH of 6,9. Some of this is explained by the lower natural pH (7,85) in the dilution seawater used in the NIVA experiments compared to the ESC experiments (8,23), but even after adjustment for that the NIVA experiment gave a slower initial increase in pH with dilution than the ESC experiment (Figure 9). The physical and chemical characteristics of the combined effluent entering the sea are given in Table 5.

Table 5. Physical and chemical characteristics of the effluent to the sea in Case 2 (combined Qatalum and Qatar Steel effluents entering the sea, without NaOH neutralization), and EQS values applied. n.a.: not applicable.

| Parameter: | Level in Qatalum effluent | Level in Qatar Steel effluent | Level in combined effluent | EQS = PNEC applied |
|--|-------------------------------------|-------------------------------|----------------------------|--------------------|
| Flow rate | 16 000 m ³ /h | 44 000 m ³ /h | 60 000 m ³ /h | n.a. |
| Temperature (min – max) | 27 – 43 °C | 26 – 42 °C | 26 – 42 °C | n.a. |
| Overtemperature relative to ambient (ΔT) | 2,9 – 8,2 °C 1) | 5,6 °C | 4,9 – 6,3 °C | +3 °C |
| Salinity | 47 PSU | 47 PSU | 47 PSU | n.a. |
| pH | 6,0 | 8,2 | 6,9 - 8,0 5) | 6,5 (7,7) |
| Alkalinity | 0,0 meq/l 2) | 2,4 meq/l | 1,8 meq/l | n.a. |
| Dissolved oxygen (DO) | 4,0 mg/l 3) | 5,0 mg/l | 4,7 mg/l | 4,5 (5,0) mg/l |
| Sulphite expressed as COD | 25,3 mg/l | 0,0 mg/l | 6,7 mg/l | 0,0 mg/l |
| Net sulphate produced from wet scrubbing | 182 mg/l | 0 mg/l | 49 mg/l | n.a. |
| Total sulphate in effluent | 4216 mg/l | 3550 mg/l | 3731 mg/l | n.a. |
| Residual chlorine (FRC) | 0,00 mgCl ₂ /l 4) | < 0,1 mgCl ₂ /l | <0,07 mgCl ₂ /l | 0,08 mg/l |

1) From Qatalum EIA, Table 6.5

2) All alkalinity is consumed in the scrubber

3) According to CtO conditions.

4) According to Hydro (2010).

5) Based on the experimental results for pH change during dilution with seawater of a simulated scrubber effluent having pH=6 after neutralization with seawater and with purging. The value 6,9 is from the NIVA trials, 8,0 from the ESC trials.

Case 3: As Case 1A with additional mixing with QPCC process water in the aeration channel.

In this case the 16,000 m³/h Qatalum effluent will be mixed with 15 000 m³/h of process water from Qatar Petrochemicals Complex (QPCC) in the aeration basin and the combined effluent from the basin will join the 44,000 m³/h Qatar Steel cooling water in the MIC channel prior to discharge to the sea. The QPCC effluent is expected to be on line 3-4 years after Qatalum. Information on the expected quality of the QPCC effluent has not been available, but if the source is only cooling water it is reasonable to expect the same quality as for the Qatar Steel cooling water effluent in Case 1 and 2. This has been used in the present assessment. We have also conservatively assumed that aeration of the QPCC water will not change the water quality. The physical and chemical characteristics of the combined effluent entering the sea are given in Table 6.

Table 6. Physical and chemical characteristics of the effluent to the sea in Case 3 (combined Qatalum, QPCC, and Qatar Steel effluents entering the sea), and EQS values applied. Characteristics for the Qatar Steel effluent are shown in Table 4. n.a.: not applicable.

| Parameter: | Level in Qatalum effluent | Level in QPCC effluent | Level in combined effluent | EQS = PNEC applied |
|--|---------------------------|-----------------------------|---------------------------------------|---------------------------|
| Flow rate | 16 380 m ³ /h | 15 000 m ³ /h | 75 380 m ³ /h | n.a. |
| Temperature (min – max) | 27 – 43 °C | 26 – 42 °C | 26 – 42 °C | n.a. |
| Overtemperature relative to ambient (ΔT) | 2,9 – 8,2 °C | 5,6 °C | 5,0 – 6,2 °C | +3 °C |
| Salinity | 47 PSU | 47 PSU | 47 PSU | n.a. |
| pH | 6,0 | 8,2 | 7,1 - 8,0 2) | 6,5 (7,7) |
| Alkalinity | 0,0 meq/l | 2,4 meq/l | 1,9 meq/l | n.a. |
| Dissolved oxygen (DO) | 4,0 mg/l 1) | 5,0 mg/l | 4,7 mg/l | 4,5 (5,0) mg/l |
| Sulphite expressed as COD | 0,0 mg/l | 0,0 mg/l | 0,0 mg/l | 0,0 mg/l |
| Net sulphate produced from wet scrubbing | 182 mg/l | 0 mg/l | 39 mg/l | n.a. |
| Total sulphate in effluent | 4216 mg/l | 3550 mg/l 3) | 3694 mg/l | n.a. |
| Residual chlorine (FRC) | 0,00 mgCl ₂ /l | < 0,05 mgCl ₂ /l | < 0,07 mgCl ₂ /l 4) | 0,08 mgCl ₂ /l |

1) According to CtO conditions

2) Based on the experimental results for pH change during dilution with seawater of a simulated scrubber effluent having pH=6 after neutralization with seawater and with purging. The value 7,1 is from the NIVA trials, 8,0 from the ESC trials.

3) Assuming no evaporation in the QPCC condensers.

4) The FRC in the QPCC effluent will rapidly (< 1 min) be consumed in oxidation of excess bisulphite in the Qatalum effluent when the two effluents are mixed. This leaves 31 000 m³ with no FRC to be mixed with the 44 000 m³ of Qatar Steel effluent having <0,1 mgCl₂/l.

7. Change in pH during neutralization and ambient dilution

Calculation of pH dilution is not straightforward as it involves a range of complex chemical interactions co-occurring with the physical mixing with ambient seawater. In the previous version of the Qatalum scrubber effluent impact assessment the pH dilution was based on two different model calculations, one by AE&E Lentjes, Germany (Hydro information) made specifically for the Qatalum effluent and one by NIVA using a simplified model directly based on the thermodynamics of the carbonate/bicarbonate/ CO_2 system taking into account also the buffering properties of natural acids of boron.

Since there was a considerable discrepancy between the results of the two models Hydro decided to base the prediction of pH changes of the scrubber effluent on empirical data generated through neutralization and dilution experiments with the appropriate types of water. These experiments, done initially by NIVA by use of a Norwegian seawater source, and finally by ESC using 5 different seawater sources outside Qatalum (cf Table 7 and Figure 10) forms the basis for the dilution pattern used to calculate the necessary ambient dilution factors for pH. The experiments (cf. Appendix B and C) had a two-step approach. First the pH change was recorded when an artificial seawater effluent acidified with sulphuric acid to $\text{pH}=3$ was neutralised with NaOH or seawater to $\text{pH}=6$. Thereafter this water was subjected to stepwise dilution with seawater and the pH change followed until ambient level was reached. Results from the latter part of the experiment are given in Figure 9.

The two experiments show a discrepancy in pattern with a somewhat slower initial pH increase during dilution in the NIVA experiments (Figure 9). The reason for this is not clear and in the impact assessment we have applied the most conservative pattern (slowest increase) represented by the blue lines in the bottom graph in Figure 9.

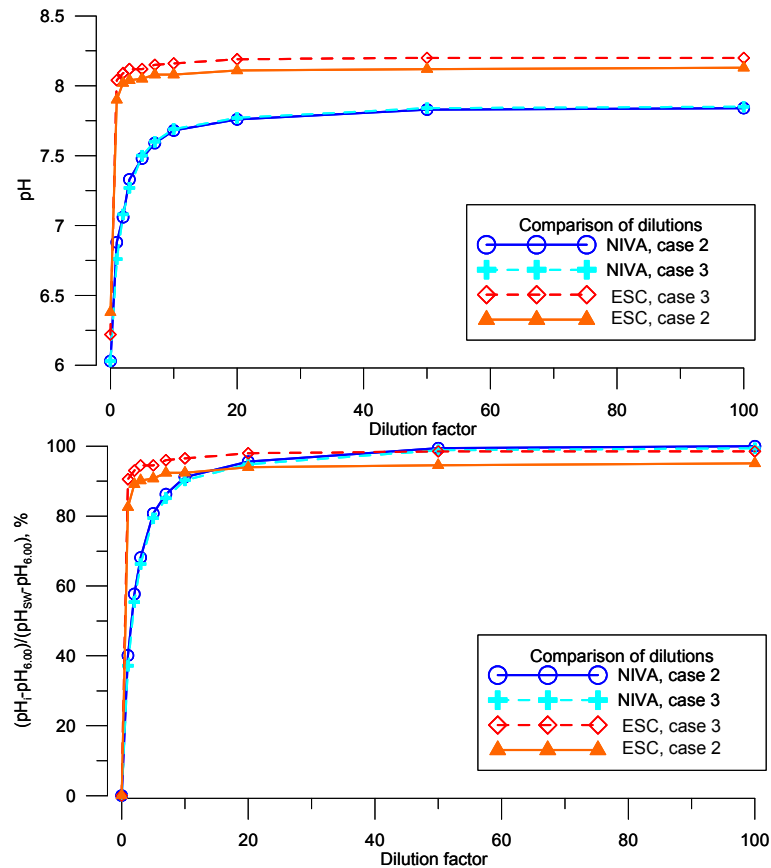

Figure 9. Top: change in pH of an experimental effluent with initial pH=6 as function of dilution with ambient seawater in the NIVA (blue) and ESC (red) experiments. The difference in endpoint pH is due to different pH in the dilution seawater used by the two consultants. Bottom: same results but normalized for this difference to facilitate the comparison¹.

7.1 Estimated supply of NaOH required for effluent neutralization

The protocol developed by NIVA requires that ESC uses a 0,05N NaOH solution in their neutralization experiments, which is equivalent to a NaOH concentration of 2 g/l. The amount of this solution necessary to raise the pH of 300 ml simulated scrubber effluent from 3 to 6 as found by ESC is shown in Table 7. Scaling these figures to the total Qatalum scrubber effluent flow of 16 000 m³/h, shows a demand of pure NaOH at a rate of 660-768 kg/h with simultaneous air purging and 757-992 kg/h without purging.

A corresponding estimate based on the design values in Figure 4 and Chapter 2.1.3 gives a net addition of 874 kg/h (380 m³/h of neutralization liquid containing a net addition of 2,3 kg/m³ of Na⁺ ions (0,1 mol/l) from the NaOH). The two estimates are in reasonable correspondence.

¹ The difference between the pH of the test effluent and the seawater used for dilution was set to 100 %. The pH increase is then scaled within this range.

Table 7. Amounts (ml) of 0,05N NaOH solution required to raise the pH from 3 to 6 in 300 ml of simulated scrubber effluents made from various local sources of seawater. The results are taken from the ESC titration experiments. The sampling points are shown in Figure 10.

| Water source for preparing simulated effluent | Amount of NaOH solution (ml) used for neutralization | |
|---|--|---------------------|
| | with simultaneous air purging | without air purging |
| Loc 1 (at Berth 8) | 6,7 | 8,1 |
| Loc 2 (at Berth 8) | 6,5 | 8,5 |
| Loc 3 (at Gabbro Berth) | 6,2 | 8,6 |
| Loc 4 (at Gabbro Berth) | 6,3 | 7,1 |
| Loc 5 (in Qatalum SW intake) | 7,2 | 9,3 |

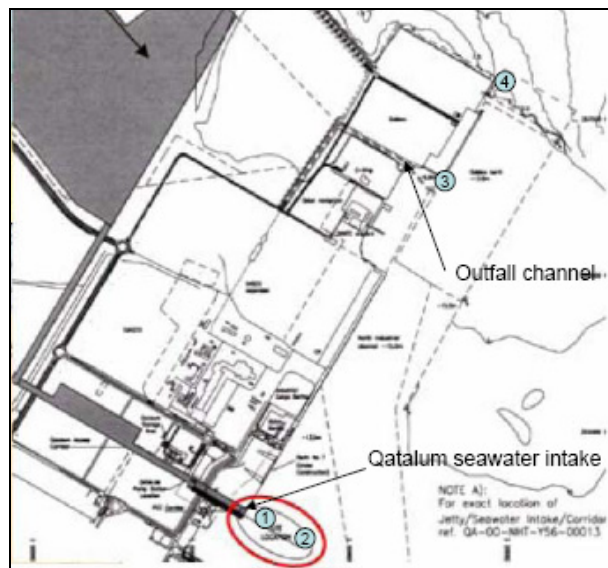

Figure 10. Sampling points for seawater samples for the ESC experiments (see also Table 7).

8. Environmental impact assessment

8.1 Ambient effluent dispersion and dilution dynamics

When the effluent from the MIC channel enters the sea a gradual mixing of the plume with ambient water will start immediately (Figure 6). In this process the levels of the various compounds and characteristics gradually approach ambient levels. If the ambient seawater has lower concentrations of chemicals of concern than the effluent, the overall concentration will gradually be reduced. The mixing and transport processes are most often described through numeric modelling, but could also be based on empirical data. In the present assessment we have used previous modelling results from d'Appolonia made available to us to estimate the change in PEC¹ levels of the various parameters with distance and time.

Often the velocity of the effluent at discharge will cause near zone turbulence and a phase of rapid turbulent primary mixing just outside the discharge point. However in less than a minute, normally, the jet driven movement of the effluent ceases and the plume will move with the ambient currents. During this secondary phase the plume will be further mixed with ambient seawater and at the same time transported away from the outlet. At a certain stage the mixing causes the PEC levels of the parameters of concern to equal the EQS or PNEC (ratio PEC/PNEC = 1), and beyond this point there is no further risk of environmental effects from that parameter. The geographical position where $PEC/PNEC \leq 1$ for all parameters is defined as the outer boundary of the impact zone. The volume increase of the effluent-ambient mixed plume necessary to reach the $PEC/PNEC=1$, is defined as the mixing or dilution factor for that compound.

For the dispersion modelling d'Appolonia has used a well tested and appropriate model CORMIX®. Their conclusion is that dilution during the primary mixing phase is <11 times for most local current situations and <3 for stagnant currents. This can be regarded as typical for channel outlets with a relatively low effluent velocity at discharge: about 0,8 m/sec for the combined Qatum and Qatar Steel effluent and 0,2 m/sec for the Qatum effluent alone. We may therefore expect that the effluent almost immediately is mixed with at least 3 times its own volume with ambient seawater. If a $PEC/PNEC < 1$ is achieved during this phase there is no reason for environmental concern since the exposure will be for less than 1 minute.

During the secondary mixing a further dilution factor of 5 (overall factor around 15 – 55 times) is achieved within a distance of 250 – 500 m dependent on current conditions.

The overtemperature reduces water density of the effluent relative to ambient and hence reduces the vertical mixing of the effluent after discharge. According to the dispersion modelling the effluent will spread horizontally far more than vertically. With a channel outlet depth of 1,2 m this should result in a plume most often distributed within the upper 1 m. This strongly reduces any risk of encounter between the effluent and seagrass communities living mostly below 2 m depth.

In Table 8 we have summarised the effluent characteristics at the outlet to the sea for the different cases and parameters (from Table 4-Table 6), the characteristics of the ambient seawater (Chapter 3), the EQS values (Table 3), and the necessary dilution factors to reach $PEC/PNEC = 1$ for each parameter.

¹ Predicted Environmental Concentration

Table 8. Overview of effluent and ambient characteristics, EQS (=PNEC) values used, and dilution factors required to obtain PEC/PNEC=1 for the effluent parameters included in the assessment of the selected discharge cases. n.a. denotes “not applicable”.

A

| Case 1A | Level in effluent (Table 4) | Ambient levels | EQS | Dilution factor |
|--|-----------------------------|----------------|-----------|-----------------|
| Flow rate m ³ /h | 60 000 | n.a. | n.a. | n.a. |
| Temperature (min – max) °C | 26 – 42 | 20-37 | 23-40 | n.a. |
| Overtemperature relative to ambient (ΔT) °C | 4,9 – 6,3 | 0 | 3 | 0,6 |
| Salinity PSU | 47 | 40-47 | n.a. | |
| pH | 7,2 - 8,0 | 8,3 | 6,5 (7,7) | 0 (0-1) |
| Alkalinity meq/l | 1,8 | 2,4 1) | n.a. | |
| Dissolved oxygen (DO) mg/l | 4,7 | 5,5-6,5 | 4,5 (5,0) | 0 (0,2-0,5) |
| Chemical oxygen demand (COD) mg/l | 0,0 | 0,0 2) | 0,0 | 0,0 |
| Total sulphate mg/l | 3731 | 3200-3650 | n.a. | |
| Residual chlorine (FRC) mgCl ₂ /l | <0,07 | 0,07 | 0,08 3) | 0,0 |

B

| Case 1B | Level in effluent (Table 4) | Ambient levels | EQS | Dilution factor |
|--|-----------------------------|----------------|-----------|-----------------|
| Flow rate m ³ /h | 16 000 | n.a. | n.a. | n.a. |
| Temperature (min – max) °C | 27 – 43 | 20-37 | 23-40 | n.a. |
| Overtemperature relative to ambient (ΔT) °C | 2,9 – 8,2 | 0 | 3 | 0 – 1,7 |
| Salinity PSU | 47 | 40-47 | n.a. | |
| pH | 6,0 | 8,3 | 6,5 (7,7) | 0 (3) |
| Alkalinity meq/l | 0,0 | 2,4 | n.a. | |
| Dissolved oxygen (DO) mg/l | 4,0 | 5,5-6,5 | 4,5 (5,0) | 0,3-0,5 (1-2.0) |
| Chemical oxygen demand (COD) mg/l | 0,0 | 0,0 | 0,0 | 0,0 |
| Total sulphate mg/l | 4216 | 3200-3650 | n.a. | |
| Residual chlorine (FRC) mgCl ₂ /l | 0,00 | 0,07 | 0,08 | 0,0 |

Continues.

C

| Case 2 | Level in effluent (Table 5) | Ambient levels | EQS | Dilution factor |
|---|-----------------------------|----------------|-----------|-----------------|
| Flow rate m ³ /h | 60 000 | n.a. | n.a. | n.a. |
| Temperature (min – max) °C | 26 – 42 | 20-37 | 23-40 | n.a. |
| Overtemperature relative to ambient (ΔT) °C | 4,9 – 6,3 | 0 | 3 | 0,6 – 1,1 |
| Salinity PSU | 47 | 40-47 | n.a. | |
| pH | 6,9 - 8,0 | 8,3 | 6,5 (7,7) | 0 (0-2) |
| Alkalinity meq/l | 1,8 | 2,4 | n.a. | |
| Dissolved oxygen (DO) mg/l | 4,7 | 5,5-6,5 | 4,5 (5,0) | 0 (0,2-0,5) |
| Chemical oxygen demand (COD) mg/l | 6,7 | 0,0 | 0,0 | 3-7 (5-14) 4) |
| Total sulphate mg/l | 3731 | 3200-3650 | n.a. | |
| Residual chlorine (FRC) mgCl ₂ /l | < 0,07 | 0,07 | 0,08 | 0,0 |

D

| Case 3 | Level in effluent (Table 6) | Ambient levels | EQS | Dilution factor |
|---|-----------------------------|----------------|-----------|-----------------|
| Flow rate m ³ /h | 75 000 | n.a. | n.a. | n.a. |
| Temperature (min – max) °C | 26 – 42 | 20-37 | 23-40 | n.a. |
| Overtemperature relative to ambient (ΔT) °C | 5,0 – 6,2 | 0 | 3 | 0,7 – 1,1 |
| Salinity PSU | 47 | 40-47 | n.a. | |
| pH | 7,1 - 8,0 | 8,3 | 6,5 (7,7) | 0 (0-1) |
| Alkalinity meq/l | 1,9 | 2,4 | n.a. | |
| Dissolved oxygen (DO) mg/l | 4,7 | 5,5-6,5 | 4,5 (5,0) | 0,2-0,5 |
| Chemical oxygen demand (COD) mg/l | 0,0 | 0,0 | 0,0 | 0,0 |
| Total sulphate mg/l | 3694 | 3200-3650 | n.a. | |
| Residual chlorine (FRC) mgCl ₂ /l | < 0,07 | 0,07 | 0,08 | 0,0 |

- 1) Expected, not measured
- 2) Omitting the ambient COD representing slowly degradable matter.
- 3) EQS + ambient level
- 4) Calculated from a net DO deficit of 4,7-6,7 = -2 mg/l. Dilution required to raise DO from -2 mg/l to +5 mg/l.

8.2 Degree of impact from the factors of concern

8.2.1 Temperature

Dilution factor necessary to comply with the EQS of +3 °C will be 1,7 or less (Table 8) for the expected effluent ΔT range. This shows that for all the cases the EQS will be reached during primary mixing, i.e. at short distance and in less than 1 minute for both scenarios. This implies that the environmental effect of overtemperature will be insignificant in all the cases.

8.2.2 pH

The dilution requirements to obtain the EQS for pH has been based on the empirical data generated in the experiments described in Chapter 7 and Appendix B and C.

As shown by Table 4 - Table 6 the lowest pH expected in the effluent from any of the cases when entering the sea is 6,0 (Case 1B). All other cases comply with the Qatari EQS before any ambient dilution has occurred. For Case 1B less than 1:1 dilution with the typical local seawater will comply with the Qatari EQS. To comply with the EQS of the US EPA 3 times dilution is sufficient in case 1B and 0 – 2 times dilution in the other cases. This implies that a pH well within the range that gives no risk to marine life, is achieved during the rapid primary mixing phase for all the cases in the evaluation, even for Case 2 involving a failure of the NaOH neutralization.

The two experiments show a discrepancy in pattern with a somewhat slower initial pH increase during dilution in the NIVA experiments (Figure 9). If the rate found by NIVA is the case also for dilution with the local ambient seawater, a dilution factor of about 5 would be required to obtain pH=7,7 in the effluent plume from Case 1A and less than this in all other cases. This dilution will be achieved well within a distance of 250 dependent on current conditions. In this zone pelagic organisms may be exposed to pH between 6 and 7,7 for a maximum period of about 15 minutes (based on the average current velocity). This is too short to elicit any effects of significance. There is little risk that benthic organisms, e.g. the seagrass beds, should encounter reduced pH since the plume will be dispersed in the upper waters.

8.2.3 Dissolved oxygen (DO) and sulphite expressed as COD

In Case 1A the DO at the outlet will be 4,7 mg/l, and there will be no COD. A dilution factor of less than 1 is required to obtain the EQS of 5 mgDO/l and even less for an EQS of 4,5 mg/l (Table 8A). According to the d'Appolonia modelling this will be reached during the primary mixing. Effluent impact on ambient oxygen conditions in Case 1A is therefore insignificant, and will cause no environmental effects.

In Case 1B the DO at the outlet will be 4,0 mg/l and there will be no COD. The necessary dilution will be less than 1 to reach the EQS of 4,5 mgDO/l and 2 or less for an EQS of 5 mgDO/l. These dilutions are also obtained during primary mixing.

In Case 2 the DO will be 4,7 mg/l and the COD 6,7 mg/l at the outlet. The DO itself would require a dilution factor of less than 1 to reach the EQS as in Case 1A. However, assuming conservatively that the sulphite is oxidised immediately, the effluent entering the sea will in the worst case have a DO deficit of -2 mg/l. A dilution factor of 3-7 is required to raise this to the EQS of 4,5 mgDO/l (Table 8C) and 5-14 if the EQS is 5 mgDO/l. The d'Appolonia model suggests that a 7 dilution in most cases will be obtained within 250 m from the outlet and 14 times within 500 m. This implies that pelagic organism encountering the effluent plume during a Case 2 may be exposed to DO levels less than 4,5 mg/l within the 250 m distance and (based on the average current velocities) for a maximum period of about 15 minutes. There is little risk that benthic organisms, e.g. the seagrass beds, should encounter reduced DO since the plume will be dispersed in the upper waters, but if it happens no impact is expected since the duration of a Case 2 will be short.

In Case 3 the DO will be 4,7 mg/l and the COD 0,0 mg/l at the outlet. This is the same as for Case 1A and the EQS will be reached during the primary mixing.

In summary the greatest ambient mixing to obtain EQS compliance for DO is 7 times during a Case 2 giving an impact zone with reduced DO out to about 250 m distance and an exposure time of about 15 minutes for pelagic organisms. This situation, reflecting a failure in the NaOH neutralization, must be expected to last for short periods only. Under normal operation a DO concentration that is not harmful will be reached within less than a minute and there will be no effects on local organisms. Relative to an EQS of 5 mgDO/l the impact zone in Case 2 is extended to 500 m.

8.2.4 Free residual chlorine (FRC)

According to Hydro (2010) the probability that the effluent from Qatalum contains FRC is very small. This is due to the reaction of the chlorine with a large excess of sulphite and especially bisulphite produced in the scrubber process:

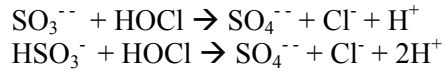

These reactions will also speed up the conversion of sulphite and bisulphite to sulphate. In fact bisulphite is used to dechlorinate treated sewage. These reactions are completed within about one minute after the effluent leaves the scrubber and hence well within the 18 minutes the effluent takes to reach the aeration chamber. Hence, if the Qatar Steel and potential QPCC effluents do not contain FRC the effluent to the sea will have no FRC in any of the treated cases. If the Qatar Steel or QPCC effluents contain FRC, and provided they comply with the regulative discharge limit of 0,1 and 0,05 mgCl₂/l for existing and new effluents respectively, the combined effluent to the sea will have a maximum FRC level of 0,07 mgCl₂/l in all the cases, and no further dilution is required to comply with the EQS (Table 8). Hence, there is little reason to expect any environmental impact from the FRC.

8.2.5 Salinity

From Chapter 2.1.3 and Figure 4 it can be estimated that the neutralization with NaOH and evaporation of the seawater in cooling towers and scrubbers give a 12% increase in concentration of Na⁺ ions in the water entering the aeration chamber relative to what is in the intake seawater. After mixing with the Qatar Steel water the effluent to the sea will have a 3% higher concentration of Na⁺ ions than the ambient seawater. Nearly all of this is due to the evaporation. Since local organisms are adapted to a salinity variation in the range 40 – 47 PSU (18 % change), this addition is insignificant.

8.2.6 Alkalinity

Reduced seawater alkalinity is not in itself of environmental concern. It should however be mentioned that a combined effect of low pH and low alkalinity can significantly increase the dilution of carbonate, and hence reduce carbonate saturation level. There is a general concern that this might reduce the ability of calcification in e.g. marine bivalves, snails and corals. These aspects are presently subjected to considerable research motivated by the general concern for seawater acidification (e.g. Widdicombe and Spicer 2008).

8.2.7 Sulphate

The typical range in natural content of SO₄²⁻ in the ambient seawater is 3200 – 3650 mg/l as function of salinity fluctuation. Complete absorption and conversion of the SO₂ in the flue gas to SO₄²⁻, assuming no limitation on oxygen availability for oxidation, will give a net contribution of combustion derived SO₄²⁻ of 181 mg/l. In addition evaporation in cooling towers and scrubbers will increase the concentration of natural SO₄²⁻ in the same way as for Na⁺, and contribute to an elevation in SO₄²⁻ concentration compared to ambient seawater. As shown in Table 8B the highest overconcentration relative to the ambient will occur in Case 1B: 4216 mg/l. Since seawater sulphate is of no general environmental concern (no EQS established) and the local organisms are adapted to a salinity variation in the range 40 – 47 PSU (18 % variability in sulphate), and since Case 1B will be of short duration, this elevation of SO₄²⁻ is not expected to cause any environmental effect.

8.2.8 Sulphide

The electrolysis process may theoretically generate sulphide ions (S²⁻) which then may absorb in the scrubber water. There is little reason to expect chemical reduction of sulphur compounds from the

scrubbing to sulphide. This will only occur under anaerobic conditions, which is unlikely in the short period from the scrubber to the aeration basin. The risk of H₂S entering the marine environment with the effluent is therefore insignificant in all the cases covered, and no sulphide impact is therefore expected. Since it is doubtful if H₂S is produced at all during flue gas scrubbing Qatalum has initiated a measurement program to provide evidence.

8.2.9 Scale inhibitor

The recommended injection of scale inhibitor to the cooling towers is 3 – 3,5 mg/l, and the concentration in the effluent will be close to 1 mg/l provided that no phosphonate is consumed in the scale inhibition process. This is equivalent to the EQS outlined in Chapter 5.2.6 and hence no dilution is required to eliminate the risk of environmental impact.

9. Conclusions

In Case 1A (neutralization and aeration of the Qatalum scrubber effluent with subsequent mixing with the Qatar steel cooling water before discharge) the pH is the effluent quality factor that determines the overall geographical zone of impact within which the ratio $PEC/PNEC \geq 1$ for one or more of the factors of concern. In the worst case pH requires a 5 times ambient dilution to comply with the PNEC or EQS. If the rate found by NIVA is the case also for dilution with the local ambient seawater, a dilution factor of about 5 would be required to obtain $pH=7,7$ in the effluent plume from Case 1A and less than this in all other cases. This dilution will be achieved well within a distance of 250 dependent on current conditions. In this zone pelagic organisms may be exposed to pH between 6 and 7,7 for a maximum period of about 15 minutes, which is too short to elicit significant effects. There is little risk that benthic organisms are exposed since the plume will be dispersed in the upper waters.

In Case 1B (Case 1A, but without the Qatar Steel cooling water available) the dilution to obtain $PEC/PNEC < 1$ is about the same for pH, overtemperature and DO (2-3 times). This will be achieved during primary mixing. The maximum duration where organisms are exposed to a $PEC/PNEC$ slightly above 1 is less than 1 minute. Furthermore, the exposure will be episodic each time only lasting for a few days.

In Case 2 (Case 1A without NaOH neutralization) the factor determining the impact zone will be COD from oxidation of sulphite. In the worst case a dilution factor of 7 is required for $PEC/PNEC$ to be less than 1 (14 if a very conservative EQS of 5 mgDO/l is used). This dilution will be achieved within 250 m from the outlet. It is confined to the zone already strongly influenced by the ship traffic to the Mesaieed Industrial City (Figure 11). Pelagic organism drifting with the water may be exposed to DO between 0 and 4,5 mg/l for a maximum period of about 15 minutes. This is hardly sufficient to damage individual plankton organisms, and will certainly not cause any significant impact on the local pelagic ecosystem. There is little risk that sea bottom organisms within the impact zone should encounter reduced DO since the plume will be dispersed in the upper waters until sufficiently diluted. This situation will only occur if the sulphite oxidation is spontaneous. A more likely situation is that the sulphite is gradually oxidised in the recipient. In that case there is no risk of a DO deficit and $PEC/PNEC < 1$ will be obtained during primary mixing.

In Case 3 (Case 1A with additional mixing of a future QPCC cooling water into the overall effluent) a dilution factor of maximum 1 is needed to achieve $PEC/PNEC < 1$ for pH and overtemperature and less than this for all the other factors of concern. Necessary dilution will be achieved during primary mixing, and the impact zone and exposure duration will be as in Case 1B.

The impact of elevated level of the ions Na^+ , SO_4^{2-} , and S^{2-} , FRC, scale inhibitor, gypsum, and calcite in the effluents has also been evaluated. There is reason to believe that FRC, gypsum, and calcite will not be present in the effluent in any of cases, and none of the others will determine the extent of an impact zone for the effluent. It is also expected that alkalinity reduction will not cause any environmental damage, although there is a general concern that chronically reduced alkalinity and lowered pH may act together to hamper development of calcareous structures in shellfish and corals. However such organisms have not been recorded and are probably not present within the impact zone.

In conclusion the maximum extent of potential environmental effects from any of the discharge cases evaluated will be a water body limited to 250 m from the channel outlet and to the upper 1 m of the water column. According to available environmental information there are no significant or sensitive habitats within this zone. Seagrass beds, which are regarded as the most valuable of the local marine ecosystems, are only found beyond 500 m distance due to earlier dredging of the harbour seafloor to

10 m depth (Figure 11). The typical depth range of the seagrass beds is from 2 to 6 m, which also is below the impact zone.



Figure 11. Satellite view of the MIC channel marine recipient. The yellow line shows the border of the potential impact area within a 250 m perimeter from the Qatalum effluent outlet (Image source: Google Earth).

10. References

- Atkins (2006). Qatalum EIA Report. Doc Ref: QA-00-ATK-F15-00001-FINAL
- Bakke T, Braaten B, Molvær J, Schaanning MT (2002). Seawater flue gas desulfurization FGD may require new regulations on ambient dissolved oxygen. Paper 71226 CEPSI Conference 2002.
- Bull JH, et al. 1982. Baseline environmental study and predictive water quality modelling, Amuay Bay, Venezuela. Prepared for Lagoven SA by AWARE Inc., Nashville, Tennessee, US.
- CEPA (1988). Chlorinated Wastewater Effluents - PLS1. Canadian Environmental Protection Act. Environment Canada – Health Canada. http://www.hc-sc.gc.ca/ewh-semt/pubs/contaminants/psl1-lsp1/chlorinated_wastewater_effluents_eaux_chlorees/index-eng.php.
- Environment Canada (1985). "Environmental Codes of Practice for Steam Electric Power Generation - Design Phase", Conservation and Protection, Hull, Que., Report EPS 1/PG/1
- Environment Canada (1992). A Survey of Chlorination Practices at the Eleven Major Power Utilities in Canada. Commercial Chemicals Branch, Conservation & Protection, Hull, Que. (unpublished).
- EU (2003) Technical guidance document on risk assessment (EU TGD). Part II. European Commission Joint Research Centre. EUR 20418 EN/2.
- GE Infrastructure (2008). Safety Data Sheet DEPOSITROL BL5301. GE Infrastructure Water & Process. Version 1.0 dated 03/04/2008.
- HERA (2004). Human & Environmental Risk Assessment on ingredients of European household cleaning products. Phosphonates (CAS 6419-19-8; 2809-21-4; 15827-60-8). Draft dated 6/09/2004. 114 pp.
- Hydro (Børgund M) (2010). Qatalum Project. Scrubber effluents environmental aspects. Report dated 14.04.2010.
- Knutzen J (1981). Effects of decreased pH on marine organisms. *Mar.Poll.Bull.*, 12, 25-29.
- Rajagopal S, Venugopalan VP, der Velde GV, Jenner HA (2003). Tolerance of five species of tropical marine mussels to continuous chlorination. *Mar. Env. Res.*, 55, 277-291.
- URS 2008. Marine Environmental Baseline Survey. URS Qatar LLC Report ref.. 44139906-REP-004 (Draft).
- Widdicombe, S, Spicer, JI, 2008. Predicting the impact of ocean acidification on benthic diversity: What can animal physiology tell us? *J.Exp.Mar.Biol.Ecol.*, 366, 187-197.
- Wolff EW. et al 1988. Proposed environmental quality standards for List II substances in water. pH. WRC Technical Report TR 259. Water Research Centre UK. 66pp.
- Wootton, JT, Pfister, CA, Forester, JD. 2008. Dynamic pattern and ecological impacts of declining ocean pH in a high-resolution multi-year dataset. *Proc. Nat. Acad. Sci.*, 105, 18848-18853.

Appendix A. Technical drawing of the scrubber effluent treatment system

Attachment 1

| | | | | | |
|------|------------|------------|----------|------|-------------------------------|
| Name | Wenzel | Kehrmann | | 04 | Issued for Detail Engineering |
| Date | 02.06.2009 | 02.06.2009 | | | |
| | Designed | Checked | Approved | Rev. | Revision Remarks |

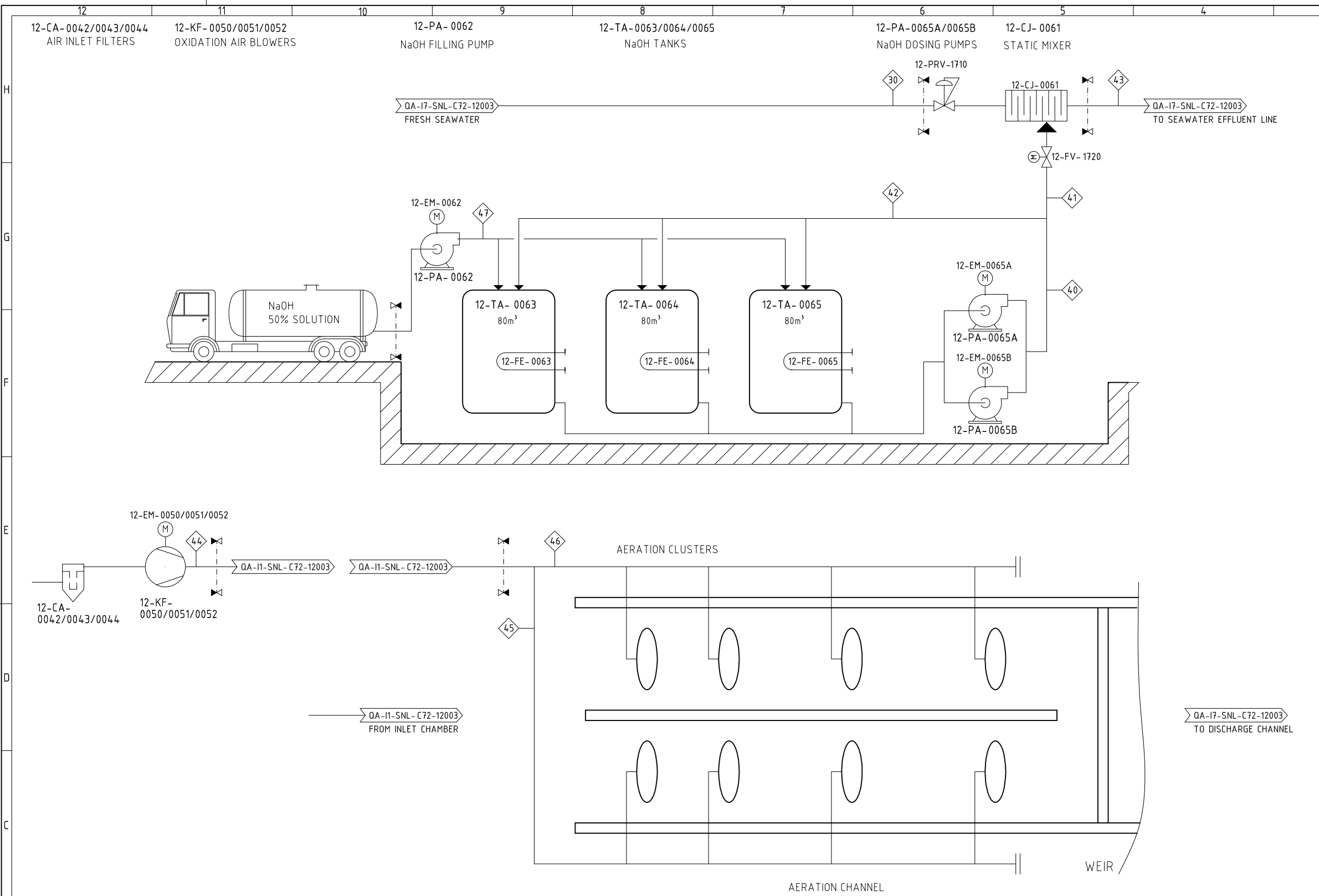

NOTE 1 STD. DRY VOLUME AIR FLOW INDICATED (0°C, 1 ATM.)

| MATERIAL BALANCE | | | | | | | | | |
|--------------------------|-------------------------------------|--------------------|------------------------------------|-------------------------|--|--|--|---|-------------------|
| Stream Number | 30 | 40 | 41 | 42 | 43 | NOTE 1 44 | NOTE 1 45 | NOTE 1 46 | 47 |
| DESCRIPTION | Flow fresh seawater to static mixer | Flow NaOH solution | Flow NaOH solution to static mixer | Flow NaOH recirculation | Flow seawater effluent to collection chamber | Flow oxidation air to aeration channel | Flow oxidation air to right side of aeration channel (in flow direction) | Flow oxidation air to left side of aeration channel (in flow direction) | Flow NaOH filling |
| FLOW RATE PHASE 1 | | | | | | | | | |
| Minimum [m³/h] | 0 | 3 | 0 | 0 | 0 | 3660 | 1880 | 1880 | 0 |
| Normal [m³/h] | 380 | 3 | 3 | 3 | 383 | 18300 | 9150 | 9150 | 15 |
| Maximum [m³/h] | 380 | 3,25 | 3,25 | 3,25 | 383,25 | 18300 | 9150 | 9150 | 15 |
| Design [m³/h] | 800 | 7 | 7 | 7 | 807 | 27460 | 23730 | 23730 | 15 |
| FLOW RATE PHASE 2 | | | | | | | | | |
| Minimum [m³/h] | 0 | 3 | 0 | 0 | 0 | 3600 | 1880 | 1880 | 0 |
| Normal [m³/h] | 380 | 3 | 0,25 | 3 | 380 | 36600 | 18300 | 18300 | 15 |
| Maximum [m³/h] | 760 | 6,5 | 6,5 | 6,5 | 766,5 | 36600 | 18300 | 18300 | 15 |
| Design [m³/h] | 800 | 7 | 7 | 7 | 807 | 45760 | 22880 | 22880 | 15 |
| TEMPERATURE [°C] | 20-35 | 20-60 | 20-60 | 20-60 | 20-35 | 95-110 | 95-110 | 95-110 | 20-60 |
| PRESSURE [bara] | 7,2 | 3,5 | 2,8 | 1,1 | 2,0 to 2,5 | 1,42 | 1,36 | 1,1 | 3,6 |

REVIEW DOES NOT CONSTITUTE ACCEPTANCE OF DESIGN DETAILS, CALCULATIONS, TEST METHODS OR MATERIALS DEVELOPED OR SELECTED BY VENDOR, NOR DOES IT RELIEVE VENDOR FROM FULL COMPLIANCE WITH CONTRACTUAL OR OTHER OBLIGATIONS.

QATALUM PROJECT
SERVICE AREA AND POTROOM BUILDING CONTRACT

VENDOR NAME: **AE&E LENTJES**

PACKAGE DESCRIPTION:
**OXIDATION AIR BLOWER STATION
NaOH DOSING STATION**

TAG: _____ MODEL TYPE: _____

CLASSIFICATION: _____ OTHER VORL CODES: _____

| | | | | |
|----------------|-----------|--------------|----------|--------|
| PURCHASE ORDER | VORL CAT. | COMPANY CODE | SEQUENCE | SUBMIT |
| 1040320 | | 72 | 0002 | 04 |

PROJECT: **5332165** DOCUMENT REFERENCE: **QA-I1-SNL-C72-1040320-0002**

| | | | | | |
|----|--------|------------|-------------------------------|----------|------------|
| 04 | WENZEL | 2009.06.02 | ISSUED FOR DETAIL ENGINEERING | KEHRMANN | 2009.06.02 |
| 03 | WENZEL | 2009.02.04 | GENERAL REVISION | KEHRMANN | 2009.02.04 |
| 02 | WENZEL | 2009.01.29 | GENERAL REVISION | KEHRMANN | 2009.01.29 |
| 01 | WENZEL | 2009.01.15 | INITIAL VERSION | KEHRMANN | 2009.01.15 |

COPYING OF THIS DOCUMENT, AND GIVING IT TO OTHERS AND THE USE OR COMMUNICATION OF THE CONTENTS THEREOF, ARE FORBIDDEN WITHOUT EXPRESS AUTHORITY BY AE&E LENTJES GbH. OFFENDERS ARE LIABLE TO THE PAYMENT OF DAMAGES. ALL RIGHTS ARE RESERVED IN THE EVENT OF THE GRANT OF A PATENT OR THE REGISTRATION OF A UTILITY.

PROJECT: **QATALUM**

AE&E LENTJES

PREPARED: 05.12.2008 WENZEL
CHECKED: 05.12.2008 KEHRMANN
APPROVED: _____

SCALE: % ORIGINAL SIZE: **A1**

IDENTIFICATION: **P21001** JOB NO. **0** UNIT **-** GROUP **-** PSP **-** DOC. TYP **PD** PREPARED NO. **AEL 0002** REVISION NO. **04**

JOB NAME: **QATALUM PROJECT** BASIS DOCUMENT: **QA-I1-SNL-C72-1040320-0002**

Attachment 2

| | | | | | |
|------|----------|---------|----------|------|-------------------------|
| Name | | | | 06 | Issued for Construction |
| Date | Designed | Checked | Approved | Rev. | Revision Remarks |

GENERAL NOTES:

- 1.- SNC-LAVALIN STRONGLY RECOMMENDS USING EXTREME CAUTION WHEN INSTALLING/CONNECTING PHASE II OR THIRD PARTY (MAPP & QPCC) PIPING. PROPER EXCAVATION AND PROTECTION PROCEDURES ARE TO BE DEVELOPPED AND IMPLEMENTED TO PREVENT DAMAGES TO BURIED PIPING.
 - 2.- QATALUM SHALL ELABORATE AND IMPLEMENT, SAFE, DETAILED AND EFFECTIVE SEALING PROCEDURES AND METHODS BEFORE CONNECTING THIRD PARTY (QPCC AND MAPP) LINES TO INSURE NO LEAKAGE ONCE THE BLIND FLANGE IS REMOVED FOR CONNECTION.
- FAILURE TO DO SO MAY RESULT IN CATASTROPHIC FLOODING OF THE EXCAVATION AND PREVENT FUTURE PIPE CONNECTIONS AND/OR CAUSE INJURIES.
- EXTREME CAUTION IS ADVISED TO INSURE AN EFFECTIVE SEAL IS ACHIEVED BEFORE LOOSENING AND REMOVAL OF THE BLIND FLANGE BOLTS.

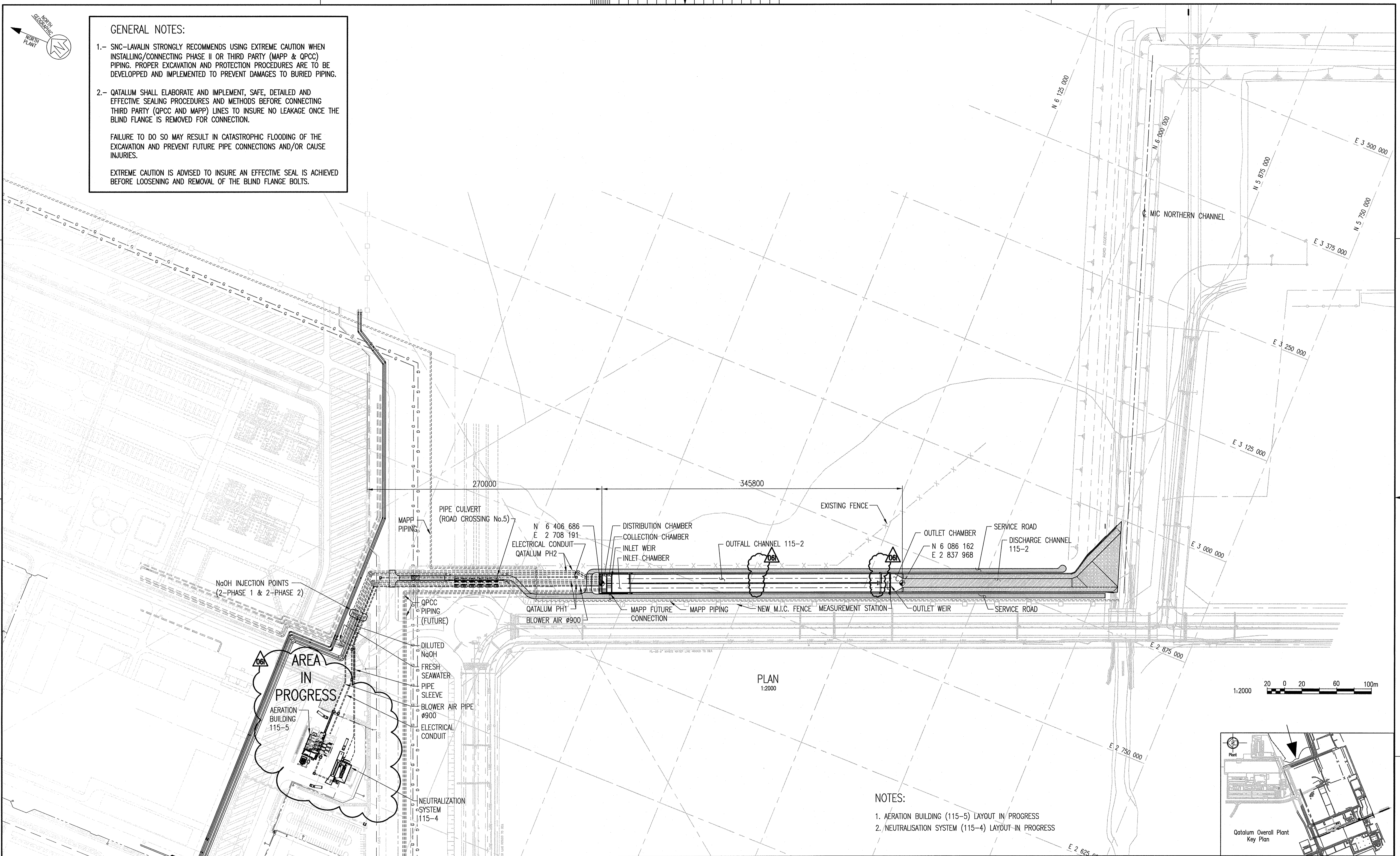

PLAN
1:2000

- NOTES:**
1. AERATION BUILDING (115-5) LAYOUT IN PROGRESS
 2. NEUTRALISATION SYSTEM (115-4) LAYOUT IN PROGRESS

| ISSUE No | REV. | DATE (Y/M/D) | PURPOSE OF ISSUE | TRANSMISSION LETTER No | ISSUE No | REV. | DATE (Y/M/D) | PURPOSE OF ISSUE | TRANSMISSION LETTER No |
|----------|------|--------------|---------------------------------|------------------------|----------|------|--------------|------------------|------------------------|
| 6 | 061 | 09/04/30 | ISSUED FOR CONSTRUCTION | | | | | | |
| 5 | 051 | 09/04/08 | ISSUED FOR CONSTRUCTION | | | | | | |
| 4 | 041 | 09/04/01 | ISSUED FOR CONSTRUCTION | | | | | | |
| 3 | 031 | 09/03/11 | ISSUED FOR CONSTRUCTION | | | | | | |
| 2 | 021 | 09/03/02 | ISSUED FOR CONSTRUCTION | | | | | | |
| 1 | 01F | 09/02/16 | ISSUED FOR DETAILED ENGINEERING | | | | | | |

| REVISION No | REVISION DESCRIPTION | DATE (Y/M/D) | INITIALS: * DESIGNED ** APPROVED | REVISION No | REVISION DESCRIPTION | DATE (Y/M/D) | INITIALS: * DESIGNED ** APPROVED |
|-------------|--|--------------|----------------------------------|-------------|----------------------|--------------|----------------------------------|
| 061 | CENTRAL SLUICE GATE RELOCATED, CENTRAL ACCESS PLATFORM DELETED, POTABLE & FIRE WATER LINES ADDED | 09/04/30 | SL | | | | |
| 051 | ELEC. ROOM IN BLOWER BUILDING, ELEC. CONDUITS & BLOWER AIR TRENCH, MODIFIED | 09/04/08 | S.C. P.T. | | | | |
| 041 | SERVICE ROAD, BLOWER BUILDING AND NEUTRALIZATION SYSTEM, MODIFIED | 09/04/01 | S.C. P.T. | | | | |
| 031 | MEASUREMENT STATION ADDED | 09/03/11 | S.C. P.T. | | | | |
| 021 | GENERAL REVISION | 09/03/02 | S.C. P.T. | | | | |

| | |
|----------------------------|---|
| PROFESSIONAL SEAL | |
| | SNC-LAVALIN International Inc. 455, Boulevard de l'Énergie Blvd. West Montréal (Québec) Canada H2Z 1Z3 |
| PREPARATION S. CIGERONE | APPROVAL P. TURCOTTE |
| DRAWN S. CIGERONE | ENGINEERING MANAGER J. VALENTE |
| CHECKED P. TURCOTTE | AREA MANAGER M. HLIVKA |
| DATE 09/02/16 | CLIENT |
| QATALUM No. | 5332165 |
| SCALE 1:2000 | |

| | |
|----------------|---|
| CLIENT | QATALUM |
| PROJECT | QATALUM PROJECT |
| TITLE | ALUMINIUM PLANT SEAWATER OUTFALL CHANNEL OVERALL LAYOUT GENERAL PLAN |
| DRAWING NUMBER | QA-S1-SNL-M56-00200 |
| REV. | 061 |

LAST SAVE: 2009/04/30 - 7:3 am
 PATH: W:\3532165\Seawater Outfall\QA-S1-SNL-M56-00200.dwg

Attachment 3

| | | | | | |
|------|----------|----------|----------|------|----------------------------|
| Name | Benthele | Kehrmann | | 06 | Actual piping and concrete |
| Date | 09.10.09 | 09.10.09 | | | |
| | Designed | Checked | Approved | Rev. | Revision Remarks |

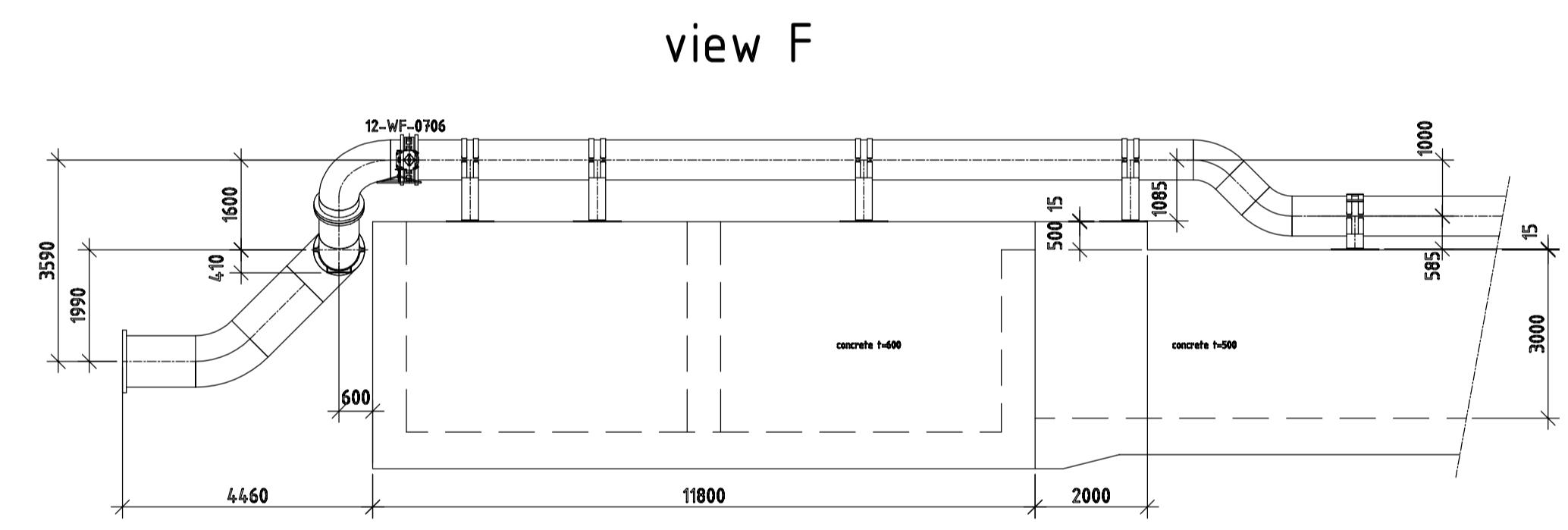
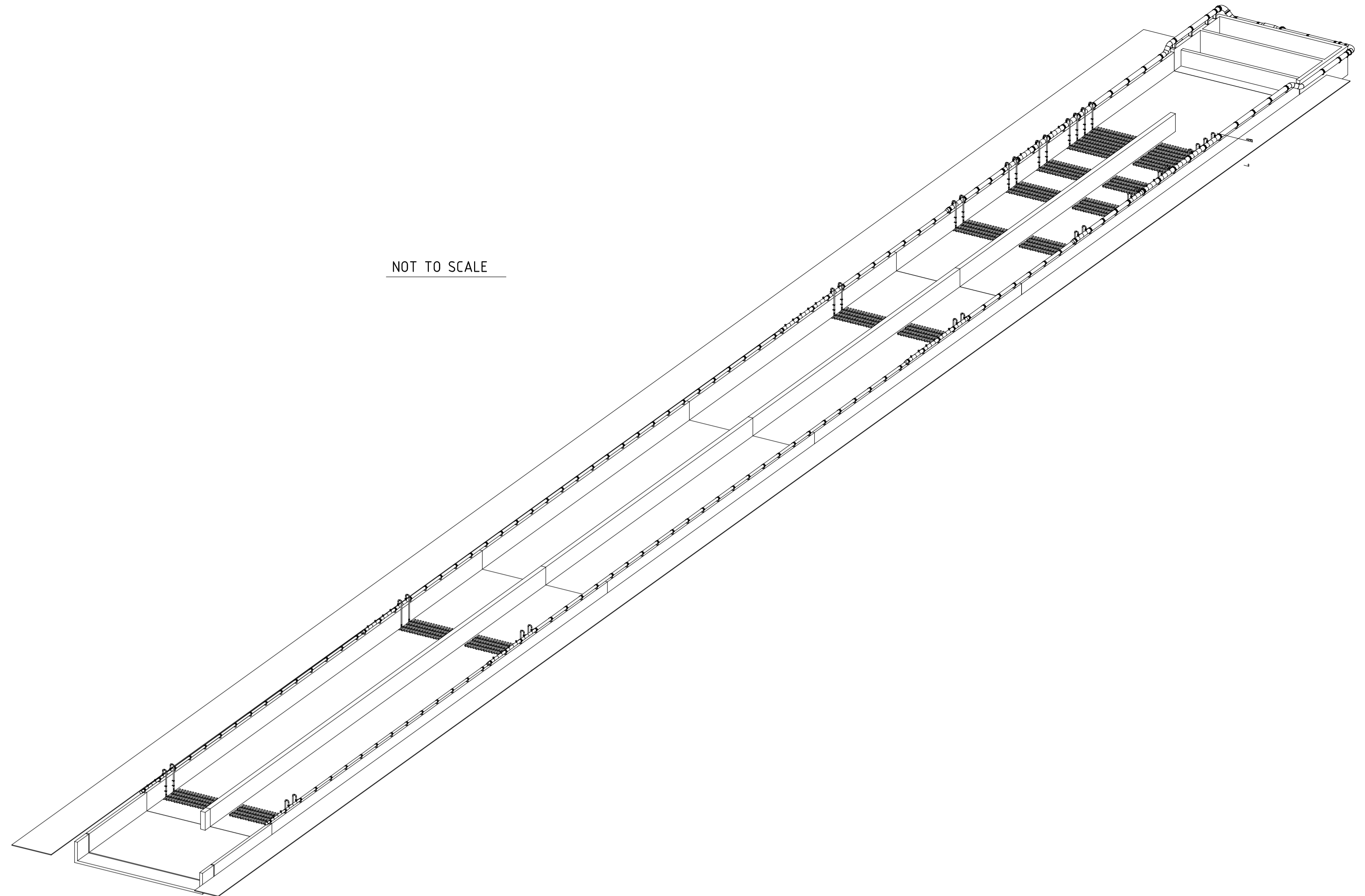
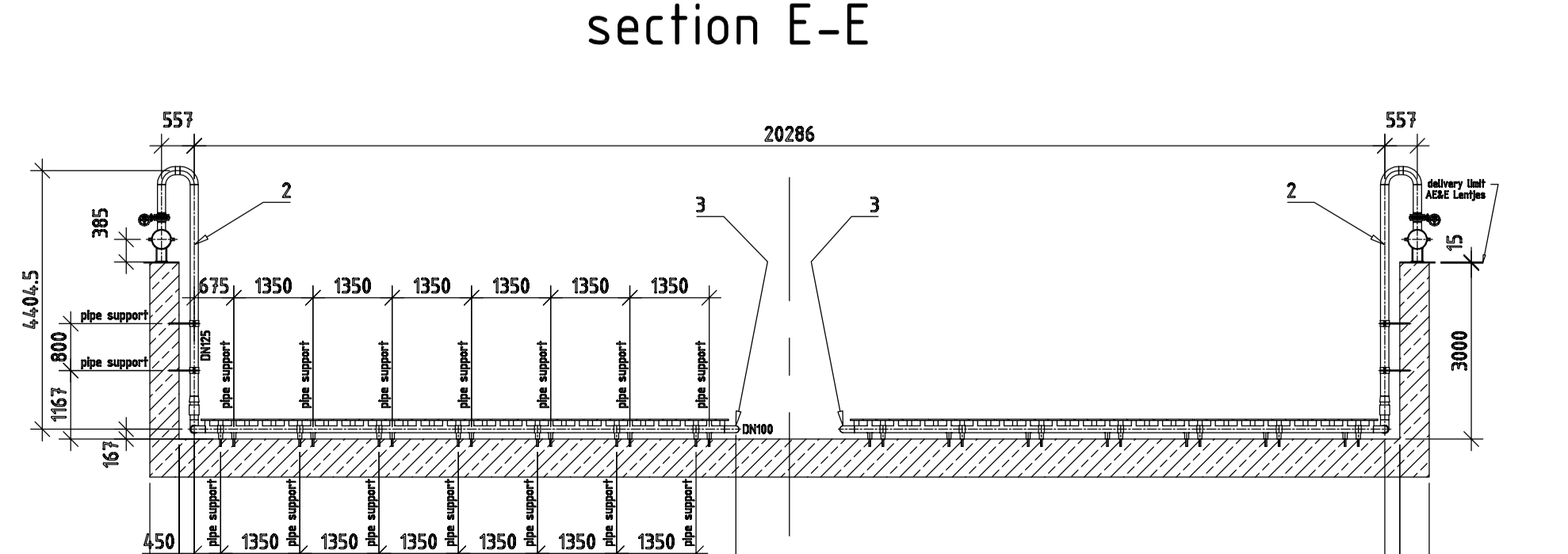
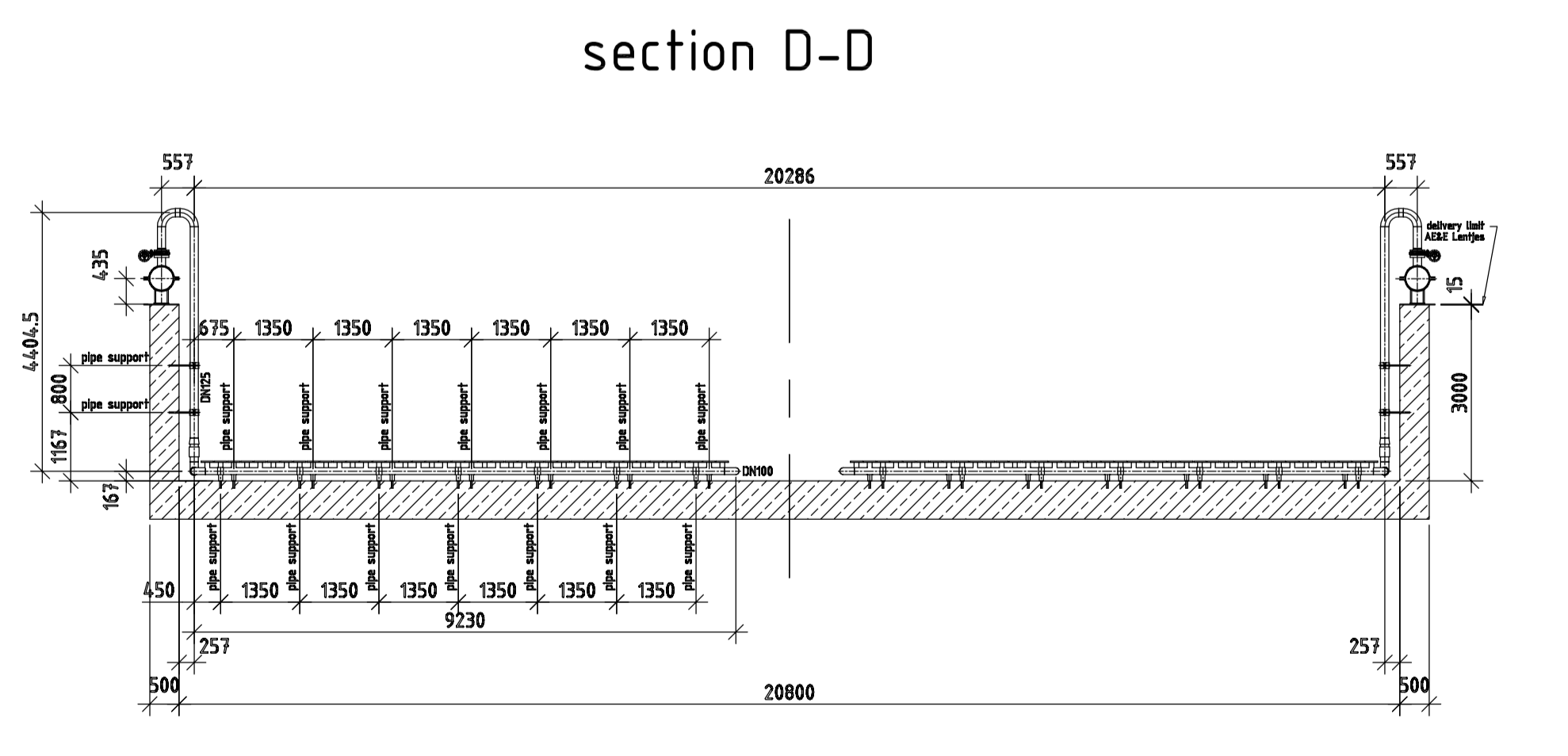
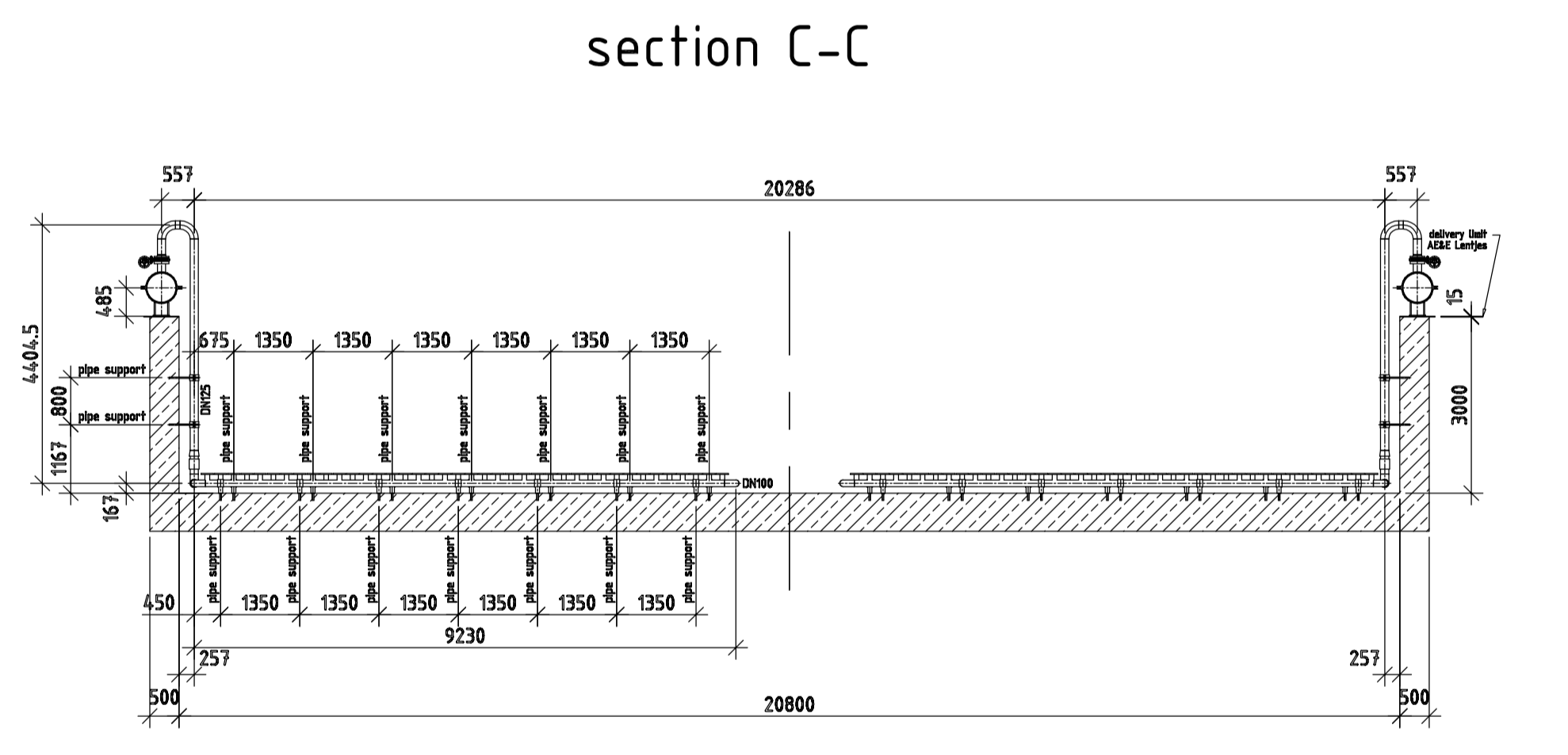
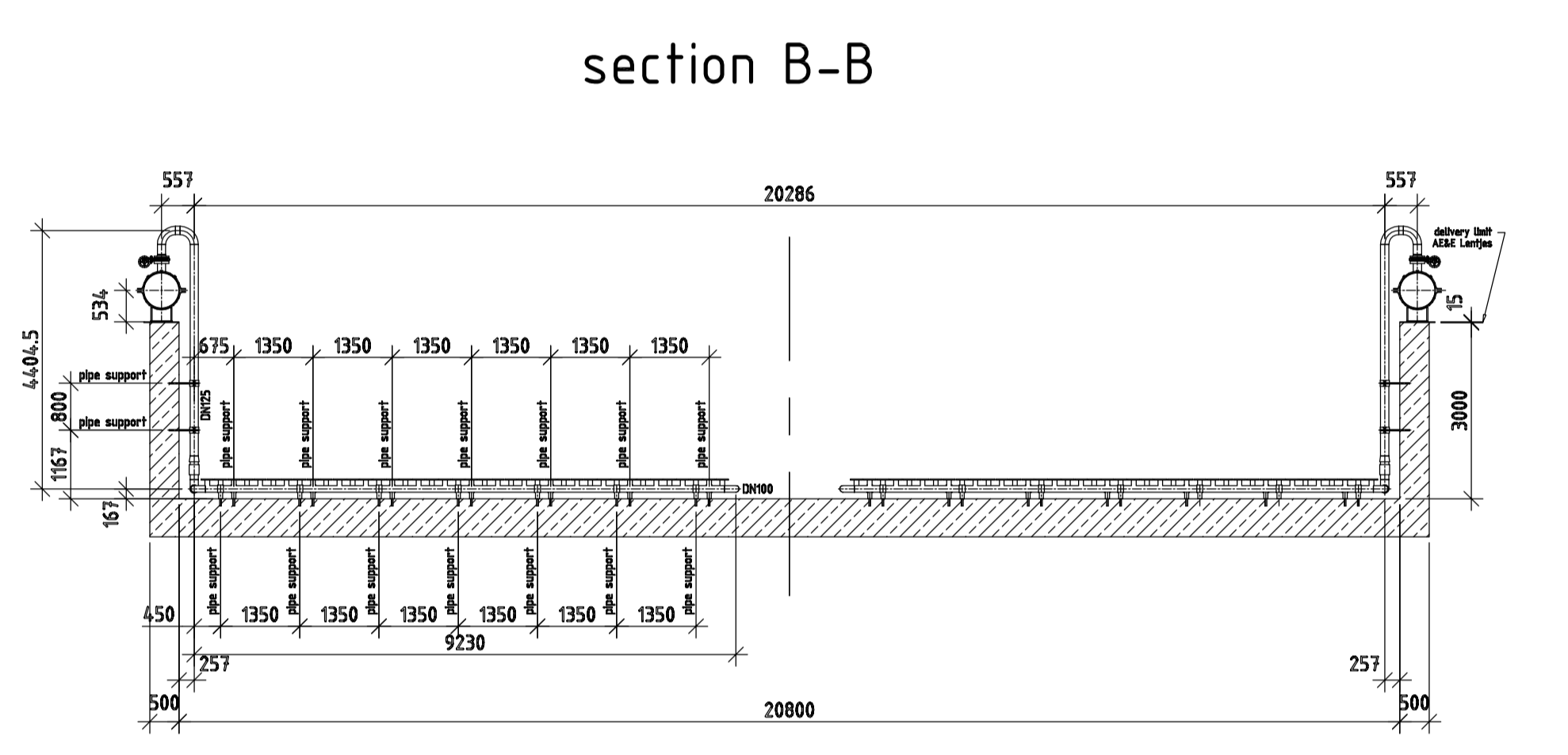
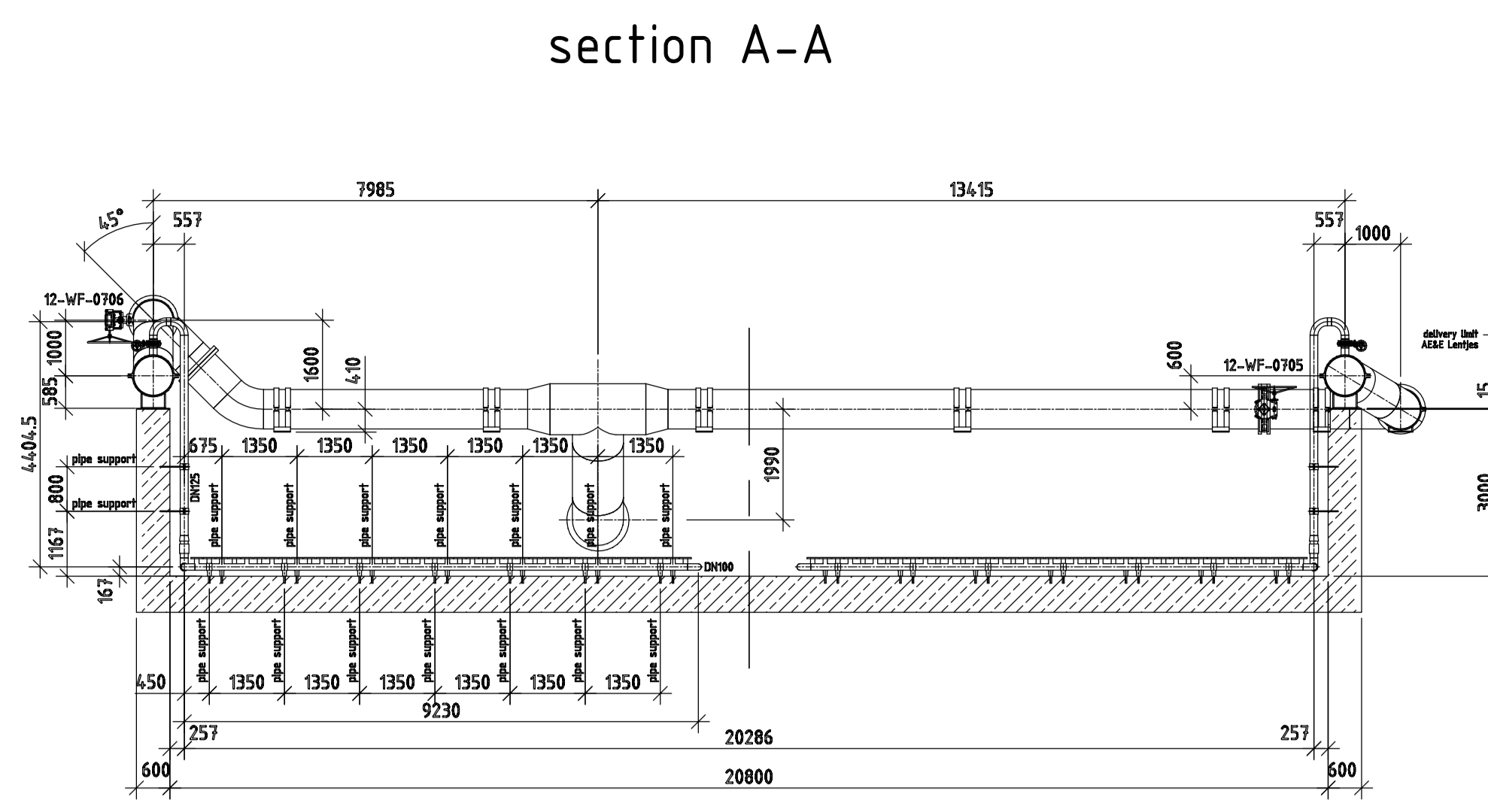
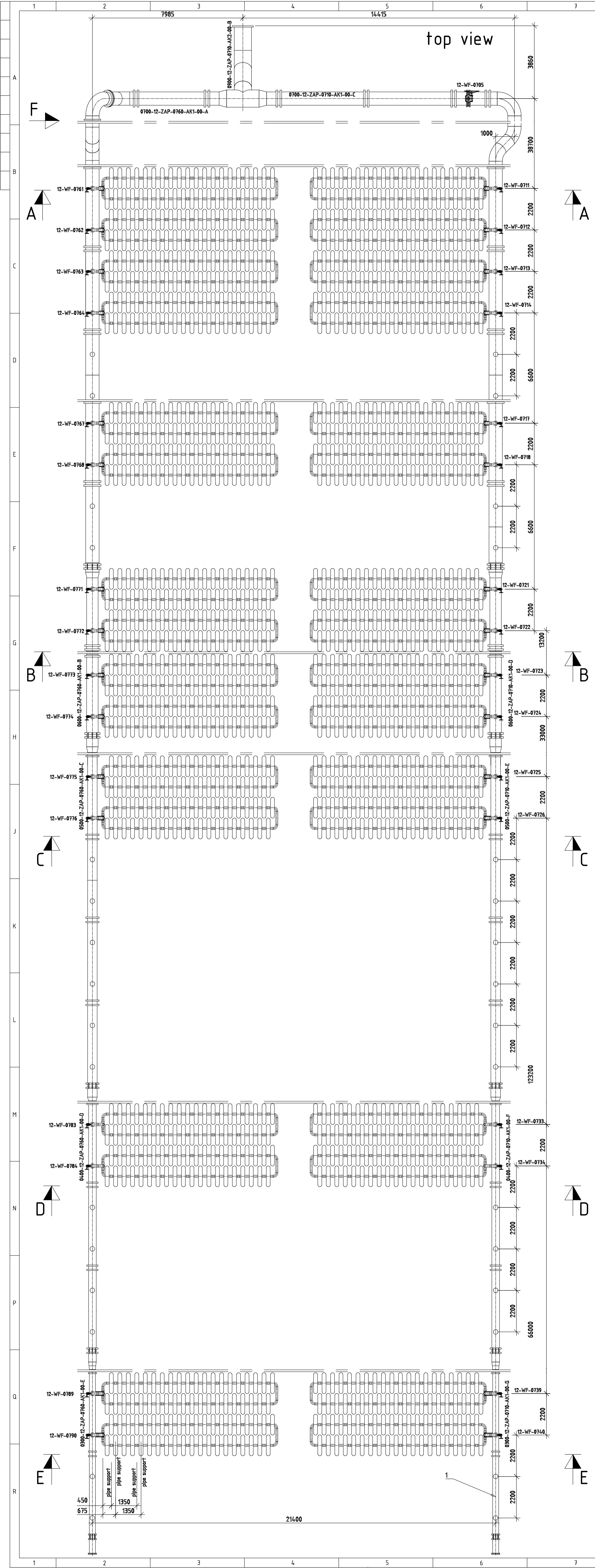

NOT TO SCALE

| COMPONENT LIST | |
|----------------|---------------------------------|
| ITEM | NOMINATION |
| 1 | Oxidation main pipe DN300-DN900 |
| 2 | Oxidation fall pipe DN125 |
| 3 | Oxidation cluster DN100 |

| | | | |
|--|--|--|--|
| REVIEW DOES NOT CONSTITUTE ACCEPTANCE OF DESIGN DETAILS, CALCULATIONS, TEST METHODS OR MATERIALS DEVELOPED OR SELECTED BY VENDOR, NOR DOES IT RELIEVE VENDOR FROM FULL COMPLIANCE WITH CONTRACTUAL OR OTHER OBLIGATIONS. | | QATALUM PROJECT SERVICE AREA AND POTROOM BUILDING CONTRACT | |
| <input type="checkbox"/> 1. REVIEWED, NO COMMENTS. RESUBMIT CERTIFIED PRINT PER VDR/L. <input type="checkbox"/> 2. REVIEWED, PROCEED WITH WORK. INCORPORATE COMMENTS AND RESUBMIT. <input type="checkbox"/> 3. NOT ACCEPTED. WORK MAY NOT PROCEED. REVISE AND RESUBMIT. <input type="checkbox"/> 4. FOR INFORMATION ONLY. | | VENDOR NAME: AE&E LENTJES | |
| NAME: _____ | | PACKAGE DESCRIPTION: ARRANGEMENT DRAWING AERATION CHANNEL | |
| DATE: _____ | | TAG: nnnn-12-ZAP-nnnn-AK1-00 | |
| SIGNATURE: _____ | | MODEL TYPE: _____ | |
| PROJECT: 5332165 | | CLASSIFICATION: _____ OTHER VDR/L CODES: _____ | |
| DOCUMENT REFERENCE: QA-H-SNL-M58-1040320-0002 | | PURCHASE ORDER: 1040320 VDR/L CAT. CODE: C.1 COMPANY CODE: 58 SEQUENCE: 0002 SUBMIT: 01 | |

| REV. | DATE | REVISED | CHECKED | APPROVED | DESCRIPTION OF CHANGE |
|------|----------|----------|----------|----------|---|
| 01 | 02.07.08 | Tschent | | | COMPRESSED AIR STATION MOVED, PIPING CHANGED |
| 02 | 25.11.08 | Pickman | | | New concept with double rectangular canal |
| 03 | 14.01.09 | Pickman | | | Size and layout of aeration plates changed, piping enlarged |
| 04 | 16.03.09 | Benthale | Kehrmann | | Oxpipe placed on top of wall |
| 05 | 01.04.09 | Benthale | Kehrmann | | Oxpipe completed at seawater inlet side |
| 06 | 09.10.09 | Benthale | Kehrmann | | actual piping and concrete |
| 07 | | | | | |
| 08 | | | | | |
| 09 | | | | | |
| 10 | | | | | |

| | | | |
|--|--|---|--|
| PROJECT: 5332165 | | DOCUMENT REFERENCE: QA-H-SNL-M58-1040320-0002 | |
| QATALUM PROJECT SEAWATER EFFLUENT TREATMENT | |  | |
| DATE: 23.06.08 NAME: Wiffkop | | SEA WATER OUTFALL OXIDATION STATION | |
| SCALE: 1:250 ORIGINAL SIZE: A0 | | JOB NO: P.21001 DRAWING NO: 00-50-001 REVISION: 06 | |
| JOB NAME: QATAR | | BASIS DOCUMENT | |

Attachment 4

| | | | | | |
|------|----------|----------|----------|------|---------------------------------|
| Name | Mib | Benthele | | 09 | Air inlet filter and compressor |
| Date | 01.10.09 | 01.10.09 | | | |
| | Designed | Checked | Approved | Rev. | Revision Remarks |

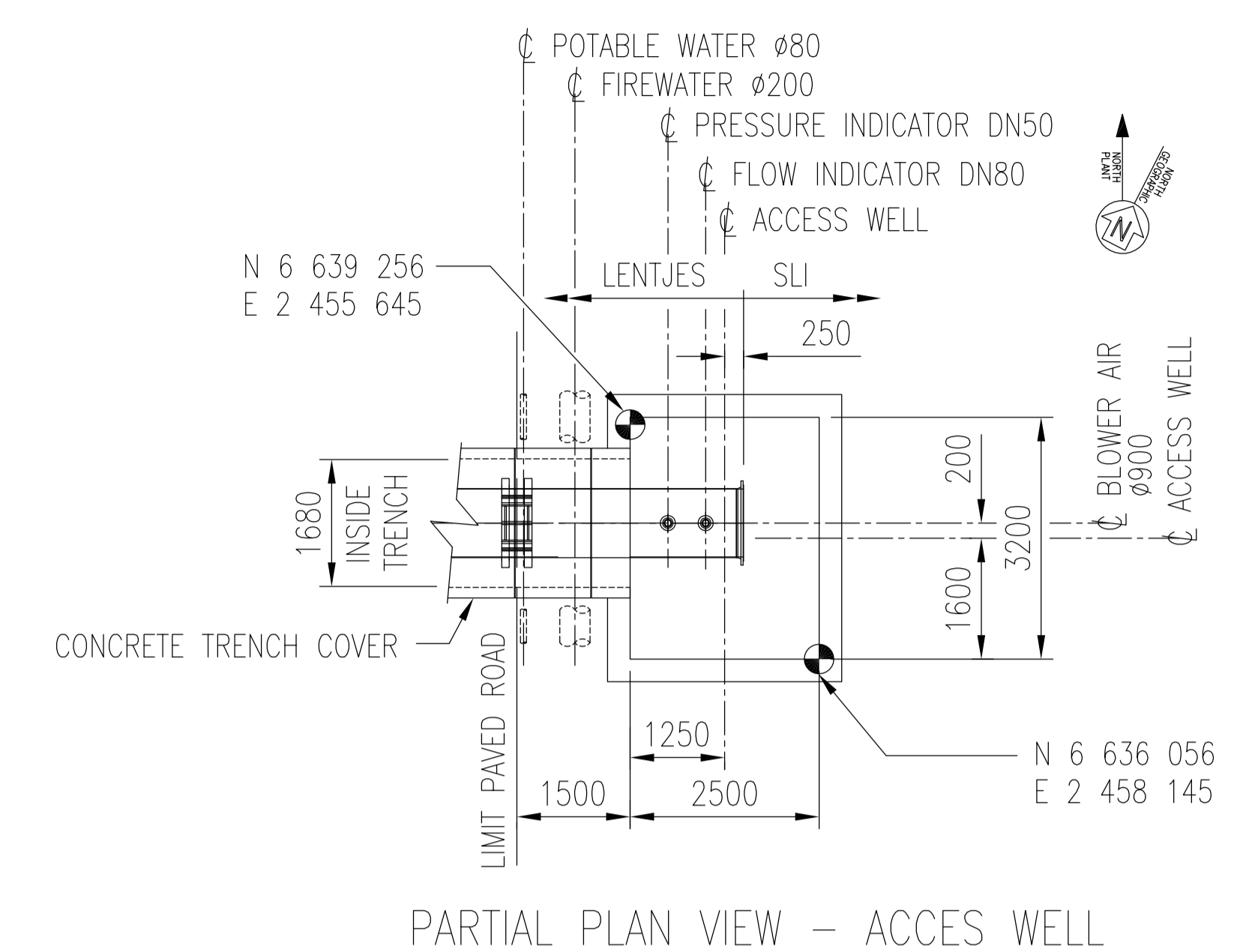
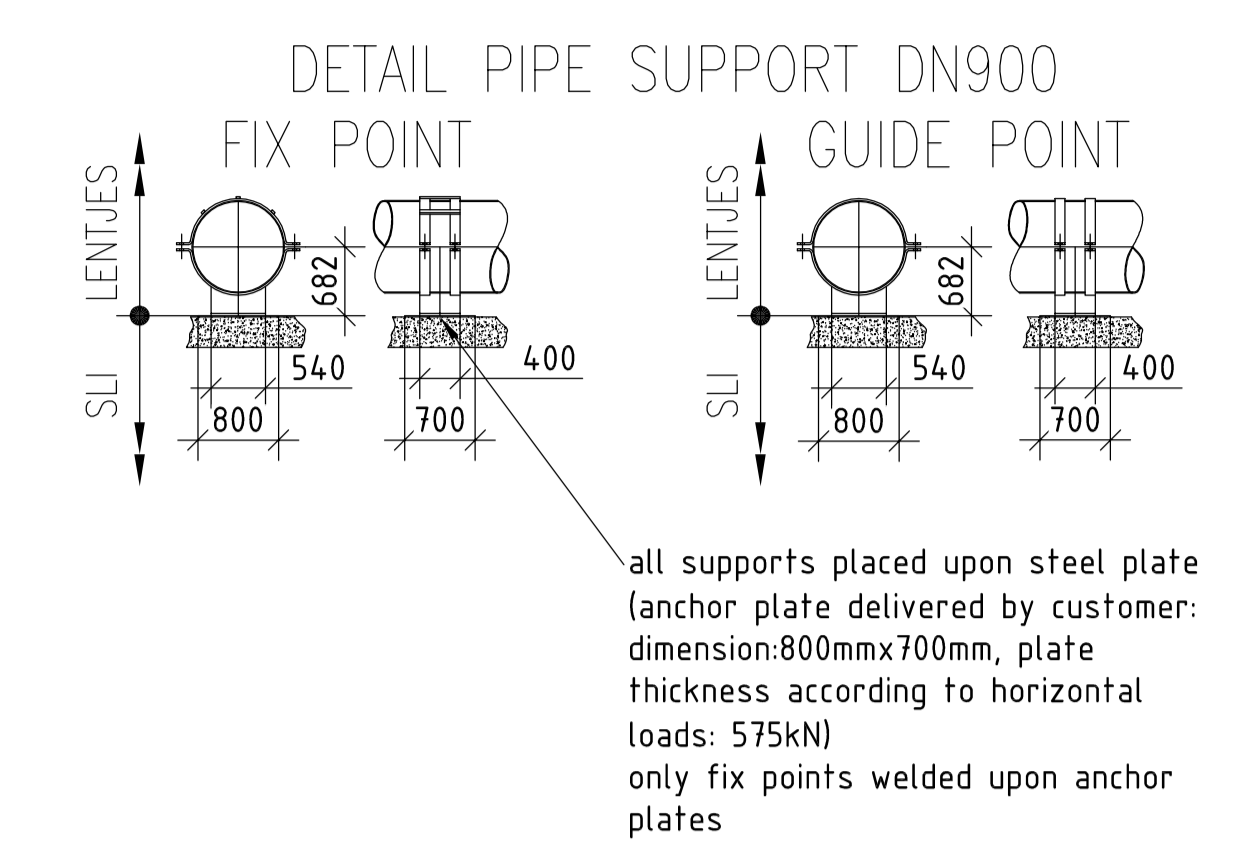
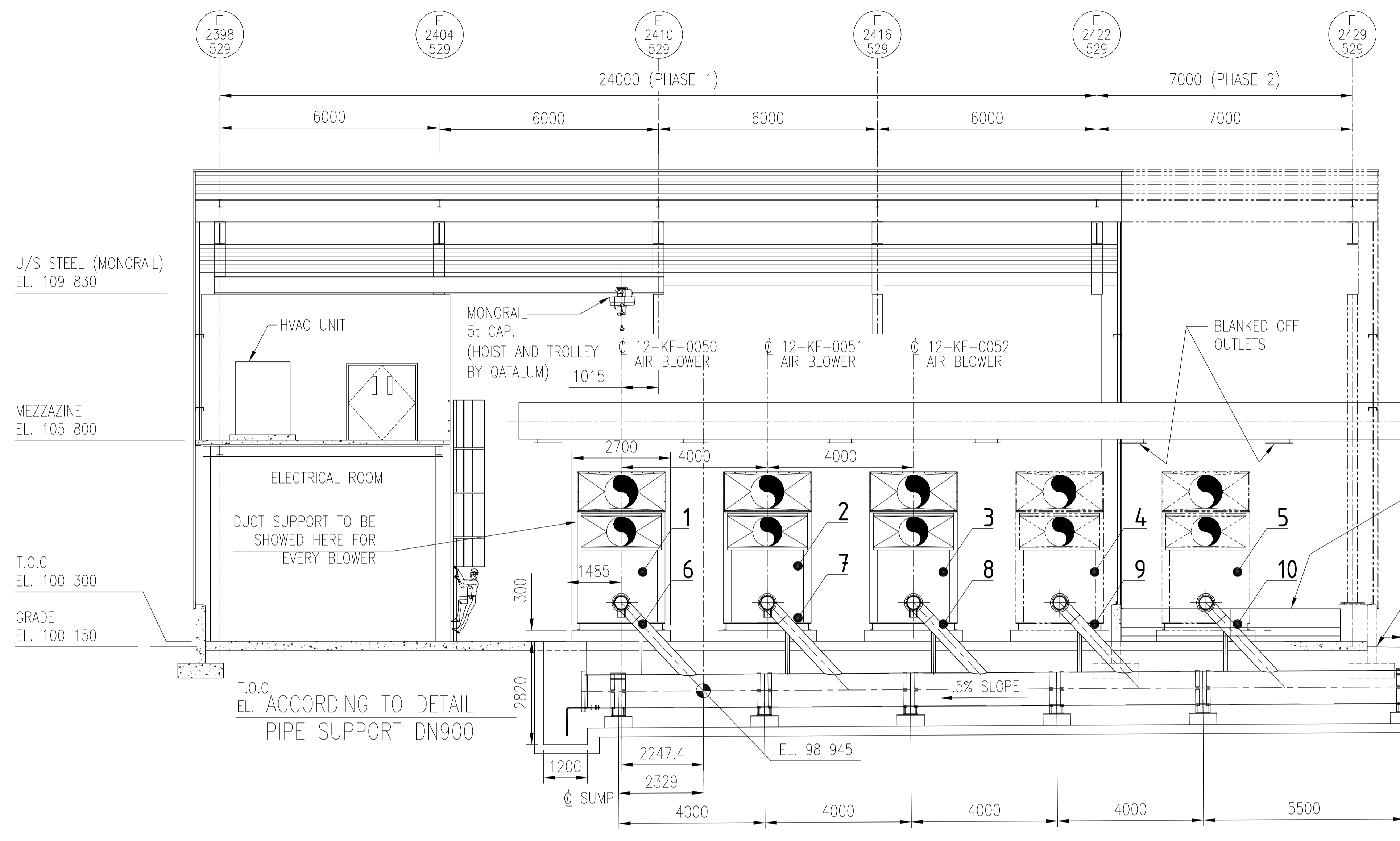

| COMPONENT LIST | | |
|----------------|------------------|---------------------------|
| ITEM | NOMINATION | PRA-CODE |
| 1 | OXYBLOWER 1 | 12-KF-0050 |
| 2 | OXYBLOWER 2 | 12-KF-0051 |
| 3 | OXYBLOWER 3 | 12-KF-0052 |
| 4 | OXYBLOWER 4 | 12-KF-0053 |
| 5 | OXYBLOWER 5 | 12-KF-0054 |
| 6 | OXY-PIPE DN350 | 0350-12-ZAP-0701-AK1-01-A |
| 7 | OXY-PIPE DN350 | 0350-12-ZAP-0702-AK1-01-A |
| 8 | OXY-PIPE DN350 | 0350-12-ZAP-0703-AK1-01-A |
| 9 | OXY-PIPE DN350 | 0350-12-ZAP-0704-AK1-01-A |
| 10 | OXY-PIPE DN350 | 0350-12-ZAP-0705-AK1-01-A |
| 11 | OXY-PIPE DN900 | 0900-12-ZAP-0710-AK1-00-A |
| 12 | AIR INLET FILTER | 12-CA-0042 |
| 13 | AIR INLET FILTER | 12-CA-0043 |
| 14 | AIR INLET FILTER | 12-CA-0044 |
| 15 | AIR RECEIVER | 12-TC-0041A |
| 16 | AIR RECEIVER | 12-TC-0041B |
| 17 | COMPRESSOR | 12-KE-0040A |
| 18 | COMPRESSOR | 12-KE-0040B |

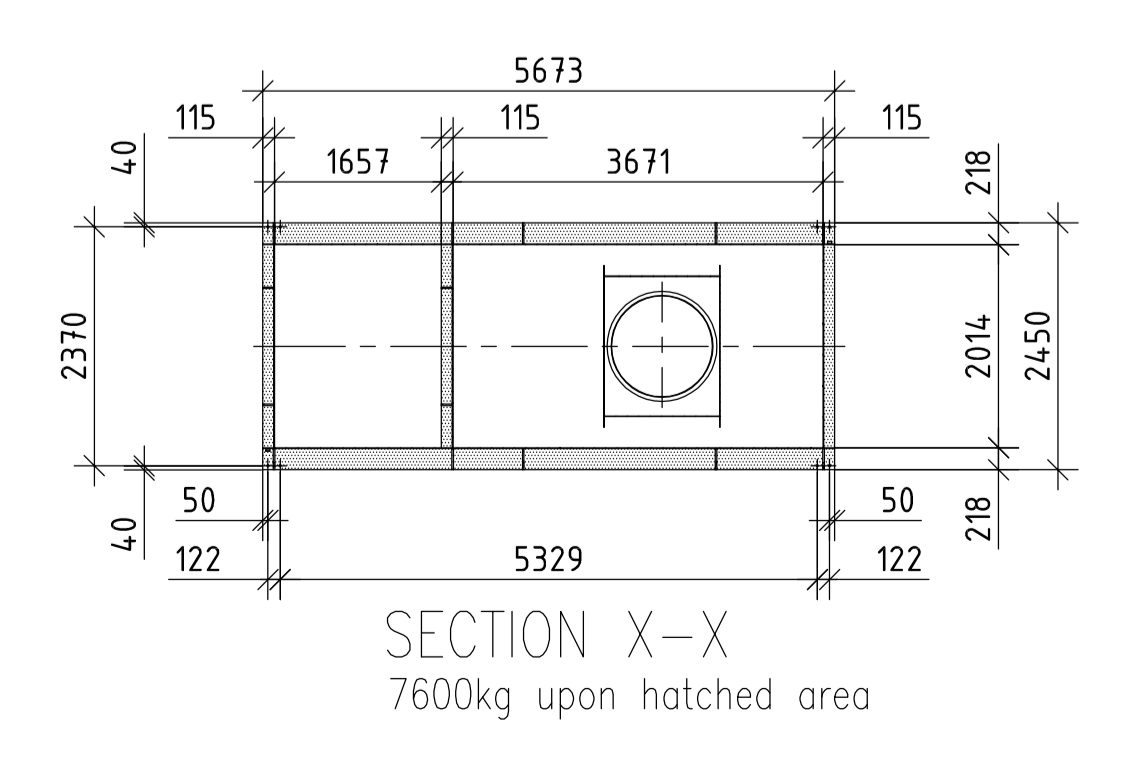
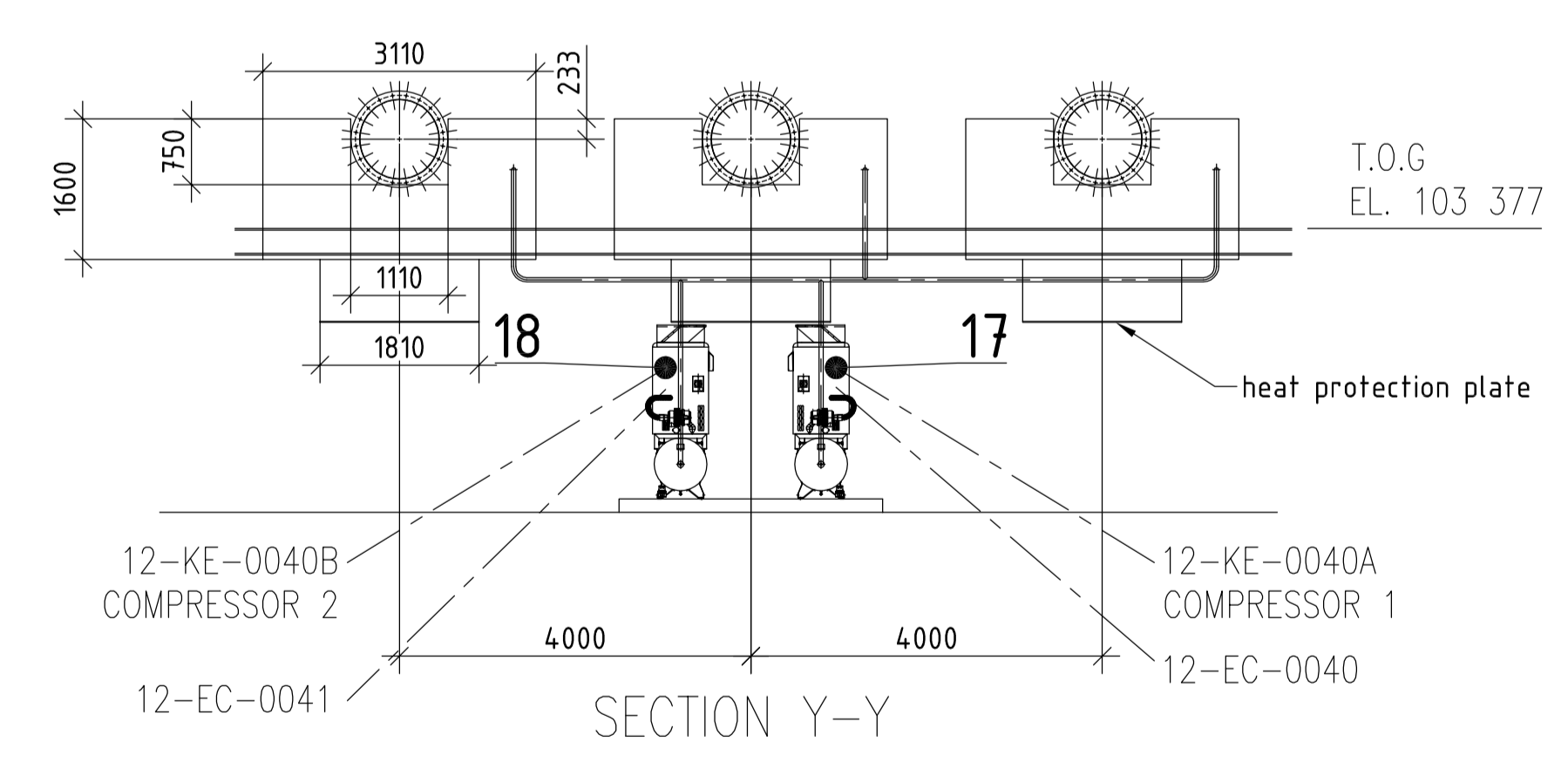
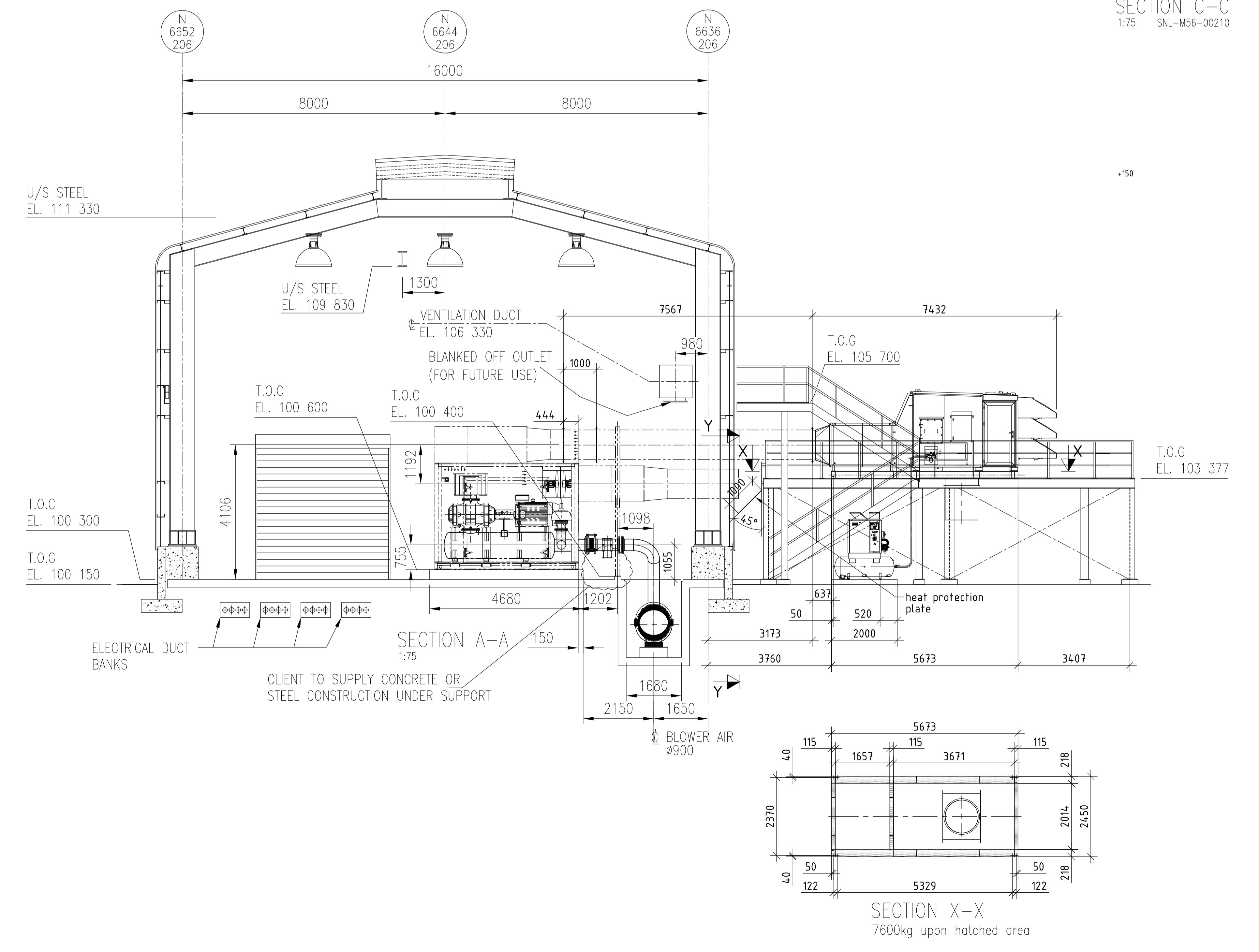

REVIEW DOES NOT CONSTITUTE ACCEPTANCE OF DESIGN DETAILS, CALCULATIONS, TEST METHODS OR MATERIALS DEVELOPED OR SELECTED BY VENDOR, NOR DOES IT RELIEVE VENDOR FROM FULL COMPLIANCE WITH CONTRACTUAL OR OTHER OBLIGATIONS.

QATALUM PROJECT
SERVICE AREA AND POTROOM BUILDING CONTRACT

VENDOR NAME: **AE&E Lentjes**

PACKAGE DESCRIPTION: **QATALUM OUTFALL EFFLUENT TREATMENT SYSTEM T-320**

TAG: _____ MODEL TYPE: _____

CLASSIFICATION: _____ OTHER VDR CODES: _____

| PURCHASE ORDER | VDR CAT. | COMPANY CODE | SEQUENCE | SUBMIT |
|----------------|----------|--------------|----------|--------|
| 1040320 | C1 | 58 | 0004 | 02 |

PROJECT: **5332165** DOCUMENT REFERENCE: **QA-11-SNL-M58-1040320-0004**

| NO | DATE | REVISION | BY | DESCRIPTION |
|----|----------|----------|----------|--|
| 09 | 01.10.09 | Mib | Benthele | AIR INLET FILTER AND COMPRESSOR |
| 08 | 07.07.09 | Peikman | Kehrmann | Cooling air supply duct height corrected, support note added |
| 07 | 07.07.09 | Mib | Benthele | dimensions added, elevation +9905 |
| 06 | 23.06.09 | Mib | Benthele | new sumps-elevation and concrete-channel |
| 05 | 08.06.09 | Benthele | Kehrmann | Support Detail for DN900 |
| 04 | 03.06.09 | Benthele | Kehrmann | Support DN900 |
| 03 | 29.05.09 | Benthele | | oxy-pipes DN900 flow meter access well |
| 02 | 13.01.09 | Benthele | | VERSION WITH ERANE AND PHOD RAIL |
| 01 | 09.01.09 | Peikman | | Ingersoll Rand Compressors |

REV. DATE. REVISION. CHECKED. APPROVED. DESCRIPTION OF CHANGE.

COPYING OF THIS DOCUMENT AND GIVING IT TO OTHERS AND THE USE OR COMMUNICATION OF THE CONTENTS THEREOF, ARE FORBIDDEN WITHOUT EXPRESS AUTHORITY BY AE&E LENTJES. OFFENDERS ARE LIABLE TO THE PAYMENT OF DAMAGES. ALL RIGHTS ARE RESERVED IN THE EVENT OF THE GRANT OF A PATENT OR THE REGISTRATION OF A UTILITY.

QATALUM PROJECT
SEAWATER EFFLUENT TREATMENT

ARRANGEMENT DRAWING
BLOWER AND INLET AIR FILTER

IDENTIFICATION: **P.21001** **00-50-008** **09**

JOB NAME: **QATAR** BASIS DOCUMENT

Attachment 5

| | | | | | |
|------|----------|----------|----------|------|------------------|
| Name | Benthele | Kehrmann | | 01 | General Revision |
| Date | 08.10.09 | 08.10.09 | | | |
| | Designed | Checked | Approved | Rev. | Revision Remarks |

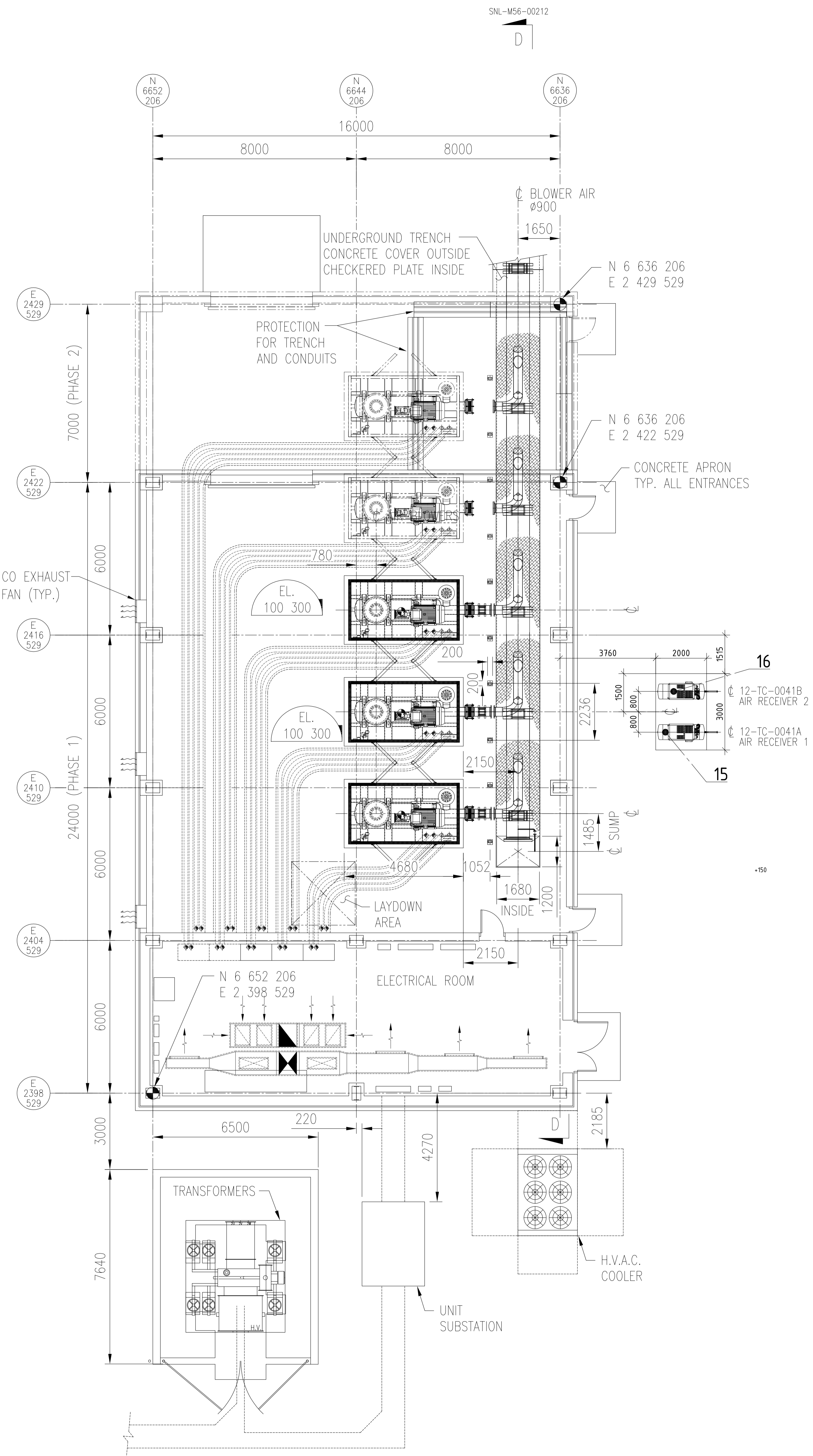

PLAN - OPERATING FLOOR @ EL. 100 300

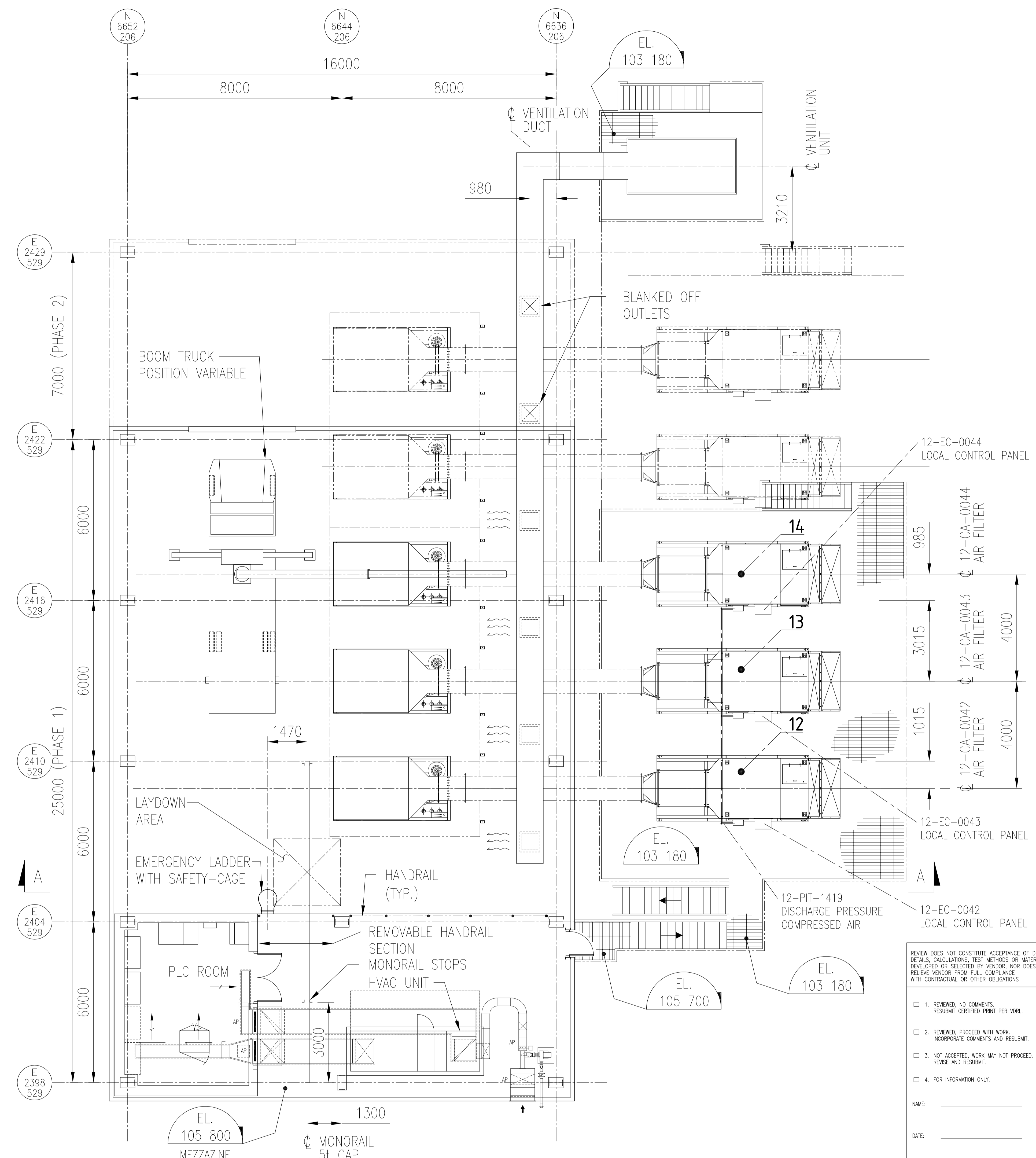

PLAN - MEZZANINE @ EL. 105 800

| | | | |
|--|--|--|--|
| REVIEW DOES NOT CONSTITUTE ACCEPTANCE OF DESIGN DETAILS, CALCULATIONS, TEST METHODS OR MATERIALS DEVELOPED OR SELECTED BY VENDOR, NOR DOES IT RELIEVE VENDOR FROM FULL COMPLIANCE WITH CONTRACTUAL OR OTHER OBLIGATIONS. | | QATALUM PROJECT SERVICE AREA AND POTROOM BUILDING CONTRACT | |
| <input type="checkbox"/> 1. REVIEWED, NO COMMENTS. RESUBMIT CORRECTED DRAWING PER VORL. | | VENDOR NAME: AE&E Lentjes | |
| <input type="checkbox"/> 2. REVIEWED, PROCEED WITH WORK. INCORPORATE COMMENTS AND RESUBMIT. | | PACKAGE DESCRIPTION: QATALUM OUTFALL EFFLUENT TREATMENT SYSTEM T-320 | |
| <input type="checkbox"/> 3. NOT ACCEPTED, WORK MAY NOT PROCEED. RE-REVIEW AND RESUBMIT. | | TAG: _____ MODEL TYPE: _____ | |
| <input type="checkbox"/> 4. FOR INFORMATION ONLY. | | CLASSIFICATION: _____ OTHER VORL CODES: _____ | |
| HWL: _____ | | PURCHASE ORDER: 1040320 VORL CAT: C1 COMPANY CODE: 58 SEQUENCE: 0005 SUBMIT: 02 | |
| DATE: _____ | | PROJECT: 5332165 DOCUMENT REFERENCE: QA-II-SNL-M58-1040320-0005 | |

| | | | |
|--|----------|---------|--------|
| 00 | | | |
| 01 | 08.10.09 | BenHale | Kernam |
| GENERAL REVISION | | | |
| (COPYING OF THIS DOCUMENT, AND GIVING IT TO OTHERS AND THE USE OR COMMUNICATION OF THE CONTENTS THEREOF, ARE FORBIDDEN WITHOUT EXPRESS AUTHORITY BY AE&E LENTJES GERM. OFFENDERS ARE LIABLE TO THE PAYMENT OF DAMAGES. ALL PROFITS ARE RESERVED IN THE EVENT OF THE GRANT OF A PATENT OR THE REGISTRATION OF A UTILITY.) | | | |

| | | | |
|--|--|---|--|
| QATALUM PROJECT SEAWATER EFFLUENT TREATMENT | | | |
| PREPARED: 19.06.09 CHECKED: BenHale APPROVED: _____ SCALE: 1:75 IDENTIFICATION: _____ | DATE: _____ NAME: BenHale ORIGINAL SIZE: _____ JOB NO.: P.21001 JOB NAME: QATAR | DESCRIPTION OF CHANGE: _____ APPROVED: _____ ORIGINAL SIZE: _____ JOB NO.: 00-50-007 DRAWING NO.: 00-50-007 REVISION: 01 BASIS DOCUMENT: _____ | ARRANGEMENT DRAWING BLOWER AND INLET AIR FILTER PLAN VIEWS |

Attachment 6

| | | | | | |
|------|----------|----------|----------|------|------------------|
| Name | Benthele | Kehrmann | | 01 | General Review |
| Date | 22.06.09 | 22.06.09 | | | |
| | Designed | Checked | Approved | Rev. | Revision Remarks |

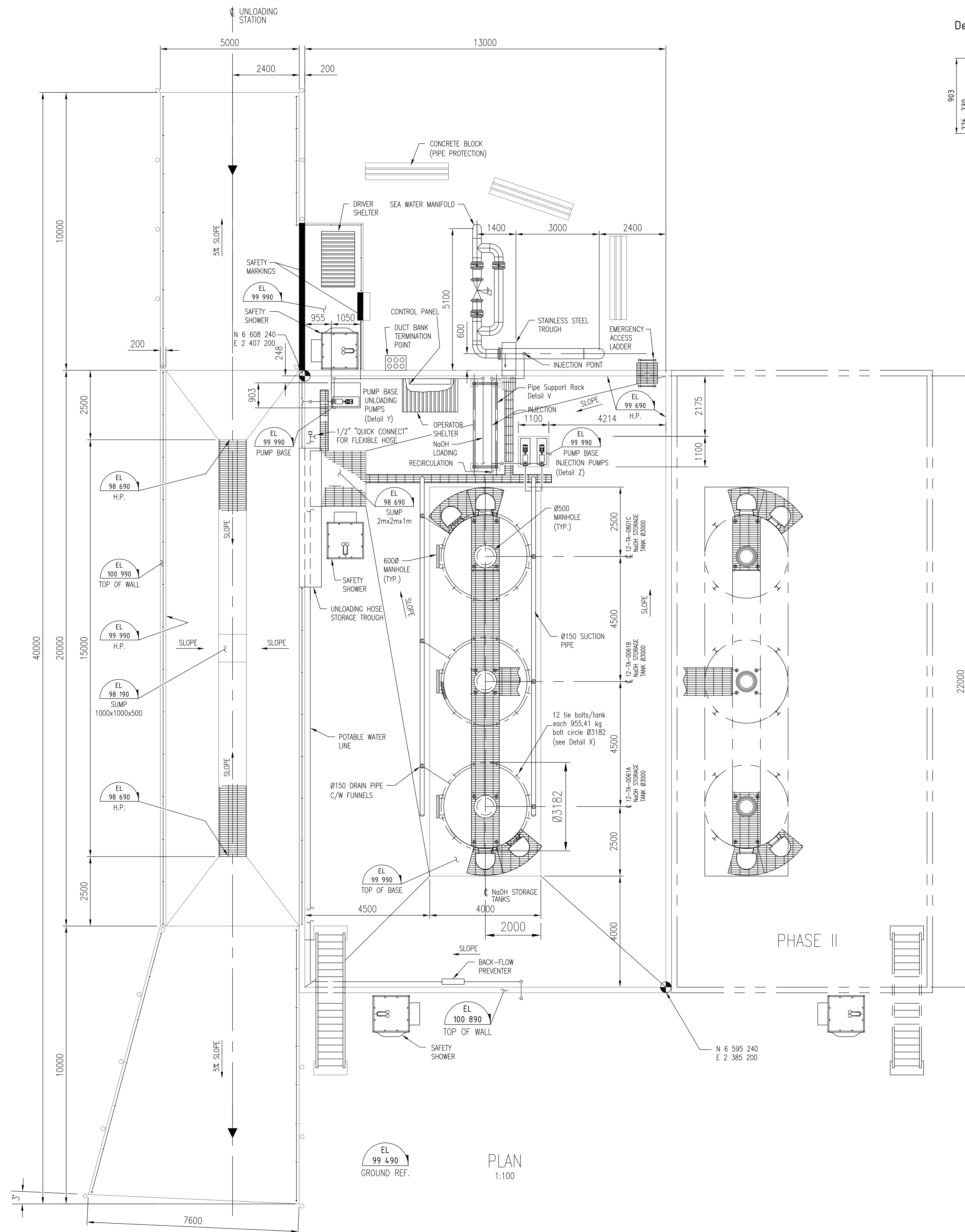

Detail Y Unloading Pump base (1:20)

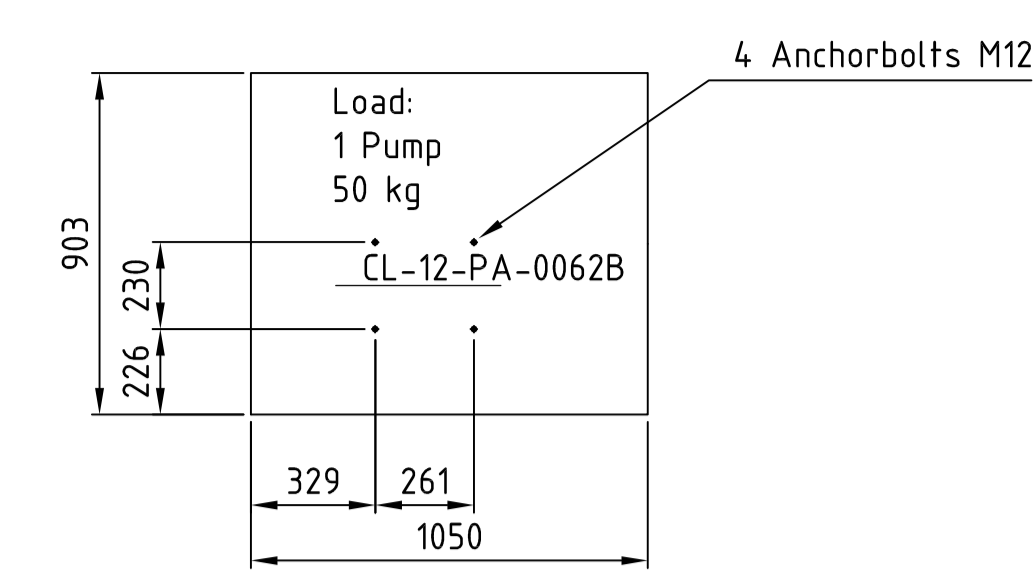

Detail Z Injection Pumps base (1:20)

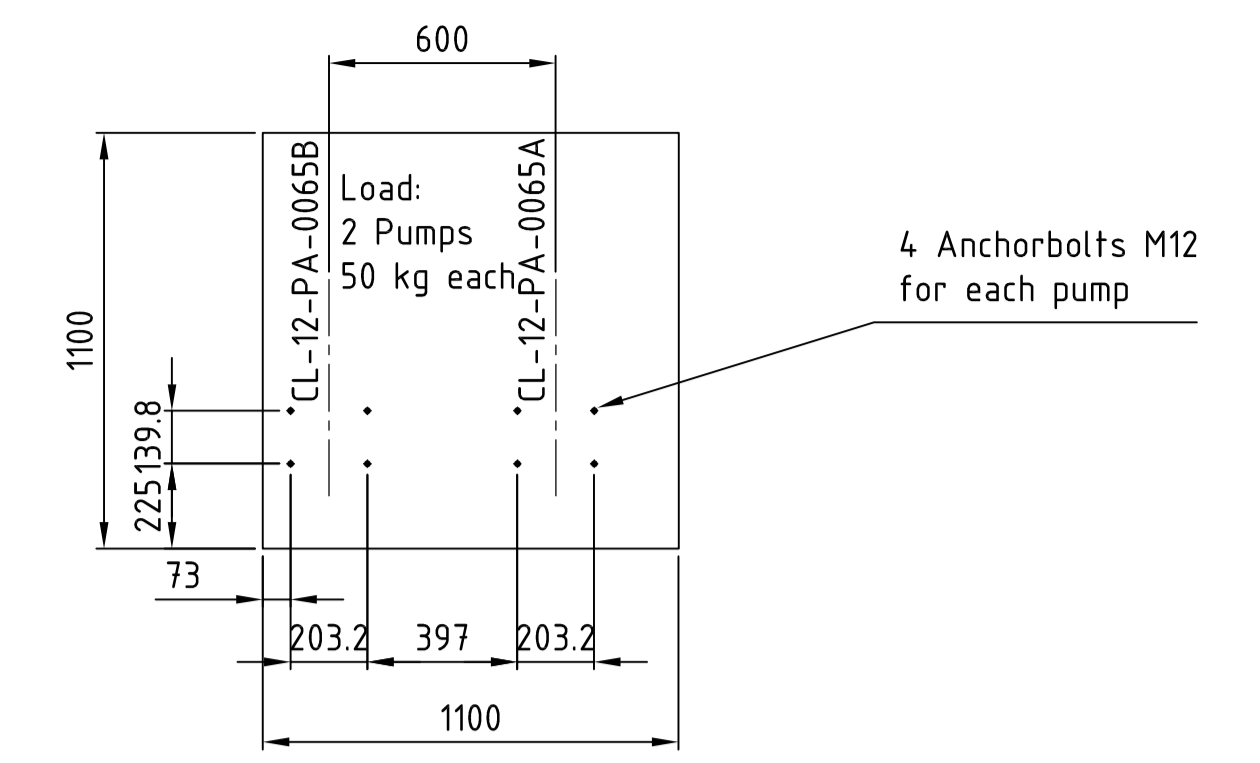

Detail V Pipe Support Rack (1:20)

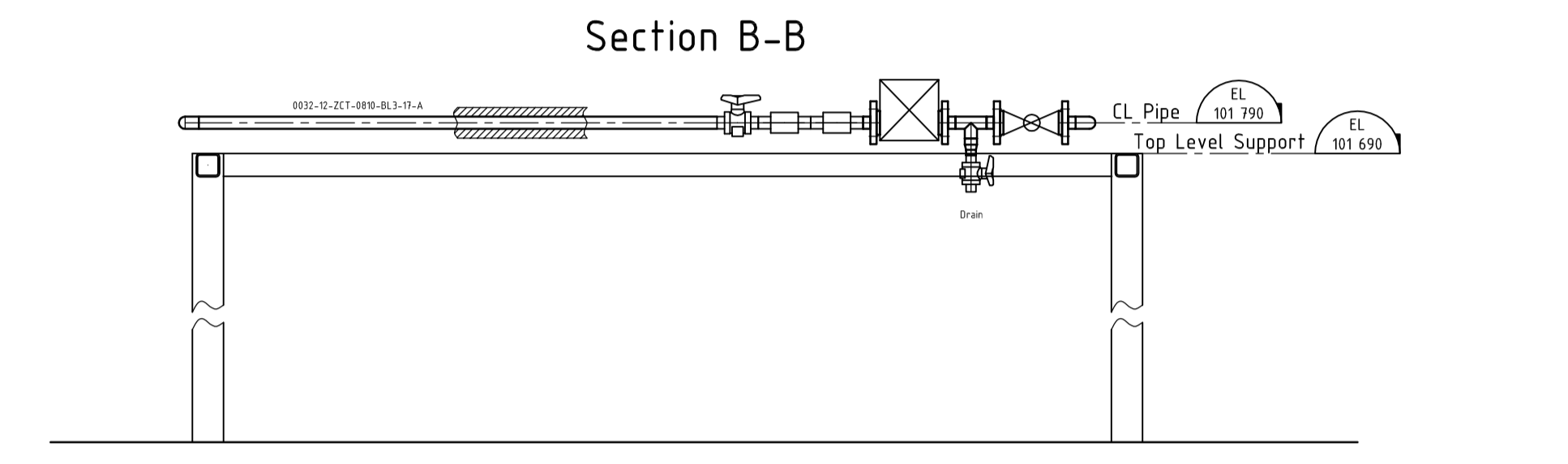

View A

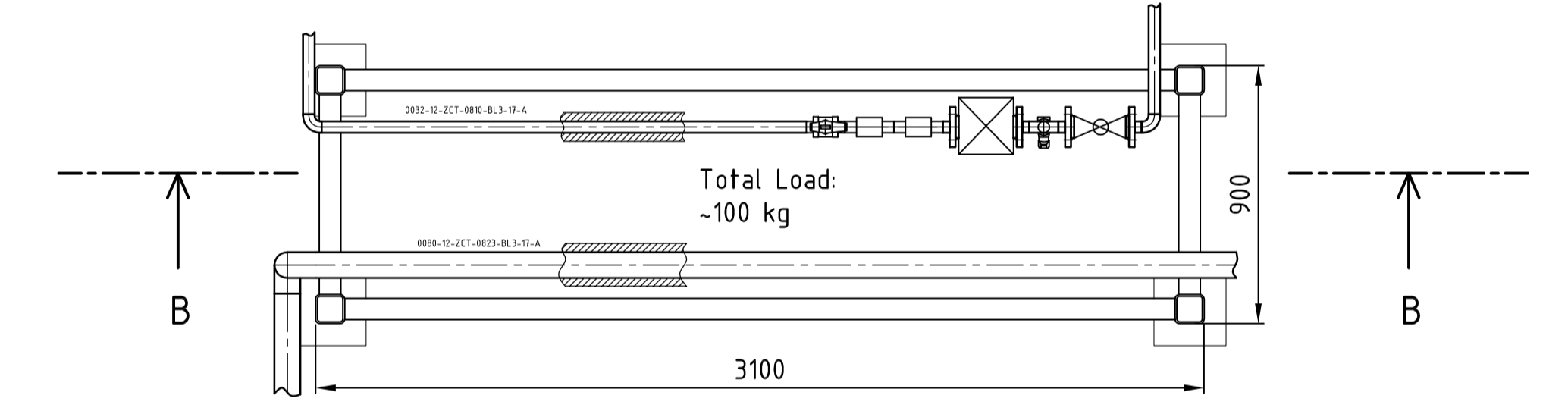

Detail X Position of Tie Bolts for Tanks

Detail drawing for tie bolts will be added later

| | | | |
|---|--|--|--|
| REVIEW DOES NOT CONSTITUTE ACCEPTANCE OF DESIGN DETAILS, CALCULATIONS, TEST METHODS OR MATERIALS DEVELOPED OR SELECTED BY VENDOR, NOR DOES IT RELIEVE VENDOR FROM FULL COMPLIANCE WITH CONTRACTUAL OR OTHER OBLIGATIONS | | QATALUM PROJECT SERVICE AREA AND POTROOM BUILDING CONTRACT | |
| <input type="checkbox"/> 1. REVIEWED, NO COMMENTS. RESUBMIT CERTIFIED PRINT PER VORL. <input type="checkbox"/> 2. REVIEWED, PROCEED WITH WORK. INCORPORATE COMMENTS AND RESUBMIT. <input type="checkbox"/> 3. NOT ACCEPTED, WORK MAY NOT PROCEED. REVISE AND RESUBMIT. <input type="checkbox"/> 4. FOR INFORMATION ONLY. | | VENDOR NAME: AE&E Lentjes | |
| NAME: _____ DATE: _____ SIGNATURE: _____ | | PACKAGE DESCRIPTION: QATALUM OUTFALL EFFLUENT TREATMENT SYSTEM T-320 | |
| PROJECT: _____ | | TAG: _____ MODEL TYPE: _____ | |
| PURCHASE ORDER: 1040320 | | CLASSIFICATION: C1 OTHER VORL CODES: _____ | |
| VORL CAT. CODE: C1 | | COMPANY CODE: 58 | |
| SEQUENCE CODE: 0003 | | SUBMIT CODE: 03 | |
| DOCUMENT REFERENCE: QA-11-SNL-Y58-1040320-0003 | | | |

| REV | DATE | REVISION | CHECKED | APPROVED | DESCRIPTION OF CHANGE |
|-----|----------|------------------|---------|----------|-----------------------|
| 01 | 22.06.09 | Bethelie Kehrman | | | General Review |

| | | | |
|---|-----------|------------|----------|
| QATALUM PROJECT SEAWATER EFFLUENT TREATMENT | | | |
| ARRANGEMENT DRAWING NaOH-TANK-STATION | | | |
| IDENTIFICATION | JOB-NO | DRAWING NO | REVISION |
| 1:60 | 73-160001 | 00-50-010 | 01 |
| JOB NAME: QATAR | | | |

Attachment 7

| | | | | | |
|------|----------|---------|----------|------|------------------|
| Name | | | | | |
| Date | | | | | |
| | Designed | Checked | Approved | Rev. | Revision Remarks |

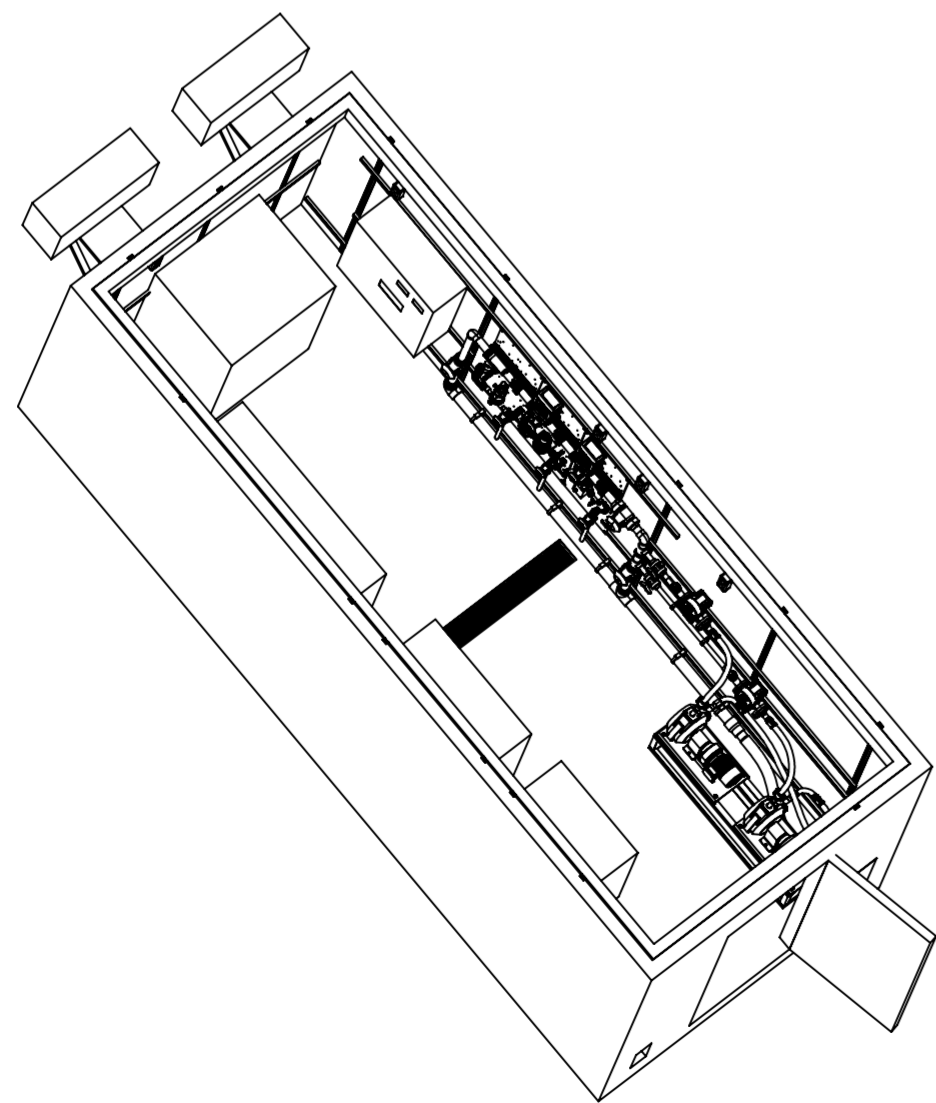
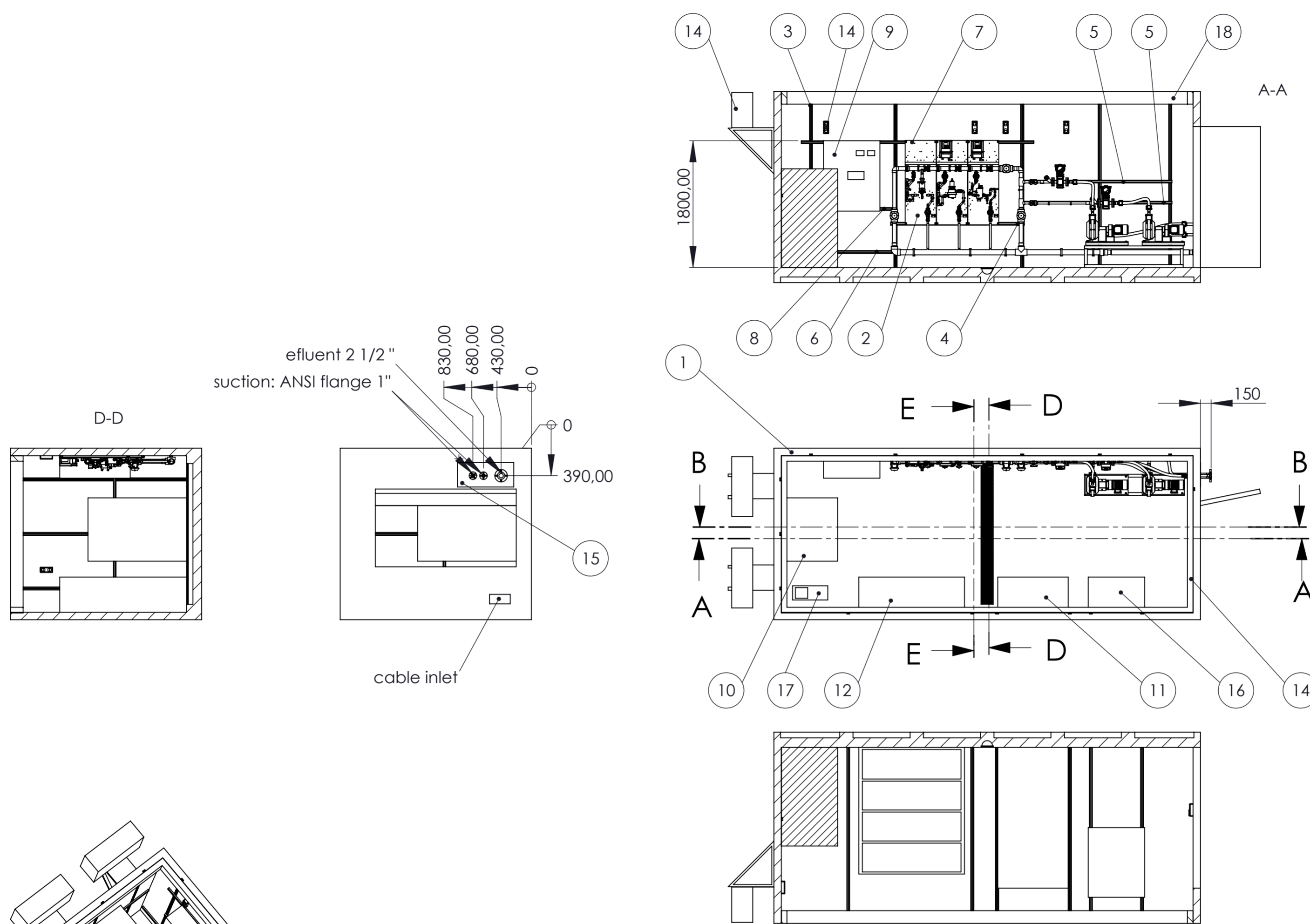

| | | | | | | |
|--|--|--|------------------|---------------------|------------------|--------------|
| REVIEW DOES NOT CONSTITUTE ACCEPTANCE OF DESIGN DETAILS, CALCULATIONS, TEST METHODS OR MATERIALS DEVELOPED OR SELECTED BY VENDOR, NOR DOES IT RELIEVE VENDOR FROM FULL COMPLIANCE WITH CONTRACTUAL OR OTHER OBLIGATIONS | | QATALUM PROJECT SERVICE AREA AND POTROOM BUILDING CONTRACT | | | | |
| <input type="checkbox"/> 1. REVIEWED, NO COMMENTS. RESUBMIT CERTIFIED PRINT PER VDRL. <input type="checkbox"/> 2. REVIEWED, PROCEED WITH WORK. INCORPORATE COMMENTS AND RESUBMIT. <input type="checkbox"/> 3. NOT ACCEPTED, WORK MAY NOT PROCEED. REVISE AND RESUBMIT. <input type="checkbox"/> 4. FOR INFORMATION ONLY. | | VENDOR NAME: AE&E Lentjes | | | | |
| | | PACKAGE DESCRIPTION: QATALUM OUTFALL EFFLUENT TREATMENT SYSTEM T-320 | | | | |
| NAME: _____ | | TAG | | MODEL TYPE | | |
| DATE: _____ | | CLASSIFICATION: 12-XX-0075 | | OTHER VDRL CODES: | | |
| SIGNATURE: _____ | | PURCHASE ORDER 1040320 | VDRL CAT. C.1 | COMPANY CODE 758 | SEQUENCE 0006 | SUBMIT 01 |
| PROJECT 5332165 | | M58 DOCUMENT REFERENCE QA-11-SNL-477-1040320-0006 | | | | |

Appendix B. The NIVA neutralization/dilution experiments

Background

During September 2009 NIVA performed a series of neutralization and dilution experiments to determine the pattern of pH change under various treatments of a simulated seawater scrubber effluent. The experiments aimed to simulate various treatment options of the Qatalum scrubber effluent, and covered combinations of neutralization with NaOH, dilution with seawater, and purging with air. On basis of the experiments a detailed protocol for such experiments was developed and submitted to Hydro to be used by Qatari laboratories on local seawater samples.

Technical description

The pilot experiments have been performed in the NIVA laboratories in Oslo. The volume scale of the experiments has been adjusted to compromise between volumes required to give representative results according to the objective and practical considerations for desk top laboratory tests. The tests consist of a series of neutralization and dilution experiments with seawater samples conditioned by use of sulphuric acid to simulate an effluent from the planned Qatalum flue gas scrubber.

Test 1. Neutralization with NaOH

The SoW given for this test was:

Determine the amount of NaOH required to neutralize to pH = 6. Measure initial pH in local seawater at e.g. 20 degrees C. Add 185 mg H₂SO₄ to 1 litre of seawater; measure resulting pH at e.g. 20 degrees C. Purge with air to see if stripping of CO₂ influences the pH. Titrate with NaOH to determine required amount to reach pH = 6. Take sufficient pH readings to get a good curve.

The experimental studies were organized according to the Protocol given in Appendix 1. The seawater and the solutions were conditioned to a temperature of 20°C.

A 2 litre glass beaker fitted with a magnetic stirrer was used for the preparation of an initial solution (**Sol-0**) simulating the scrubber effluent. A volume of 0.1 ml of concentrated H₂SO₄ (with the density 1.84 kg/l) was added to 1 litre of seawater (SW) obtained from 60 m depth at the NIVA Marine Research Facility Solbergstrand (with initial pH=7.86). The resulting pH for temperature 20°C was 3.06 (3.03, 3.06 in a parallel experiment). Here and below the pH is given in NBS units. The pH of this solution was stable for several days.

Further experiments were done with 300 ml samples of the **Sol-0**.

The results of titration with 0.05N NaOH without purging and with purging are shown in Figure 1.

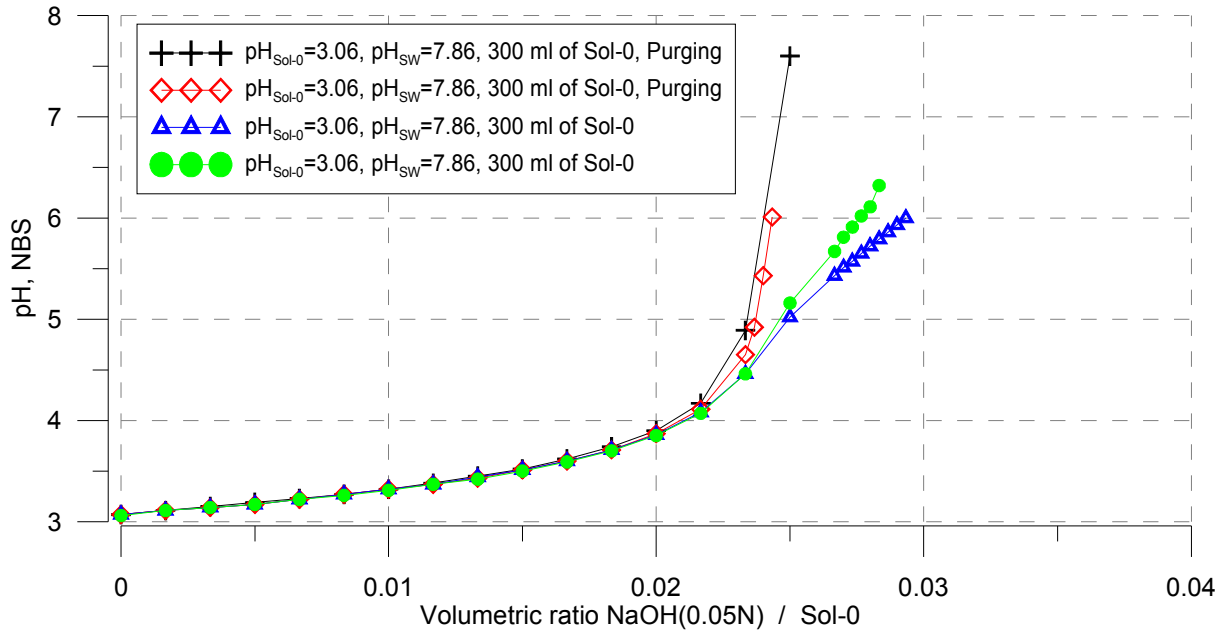

Figure 1. Ratio between the NaOH (0.05N) and initial solution Sol-0 (1.85 mg H₂SO₄ in 1 l of the SW) necessary to reach pH=6. Titration applied for 300 ml of Sol-0 with and without purging.

Under moderate mixing with a magnetic stirrer (300 rpm) and without purging the volumetric ratio between NaOH (0.05N) and **Sol-0** should be 0.025-0.029 to reach pH=6.0. In case of purging this pH value is reached at ratio 0.023-0.024.

Test 2. Neutralization with seawater

The SoW given for this test was:

Determine the amount of seawater required to neutralize to pH = 6: Initial steps as above, then titrate with seawater to determine required amount to reach pH = 6. Take sufficient pH readings to get a good curve

Under moderate mixing with a magnetic stirrer (300 rpm to avoid formation of bubbles) and without purging the volumetric ratio between SW and **Sol-0** is 1.13-1.17 when pH=6.0 is reached (Figure 2). In case of purging this pH value is reached at ratio 0.55-0.59.

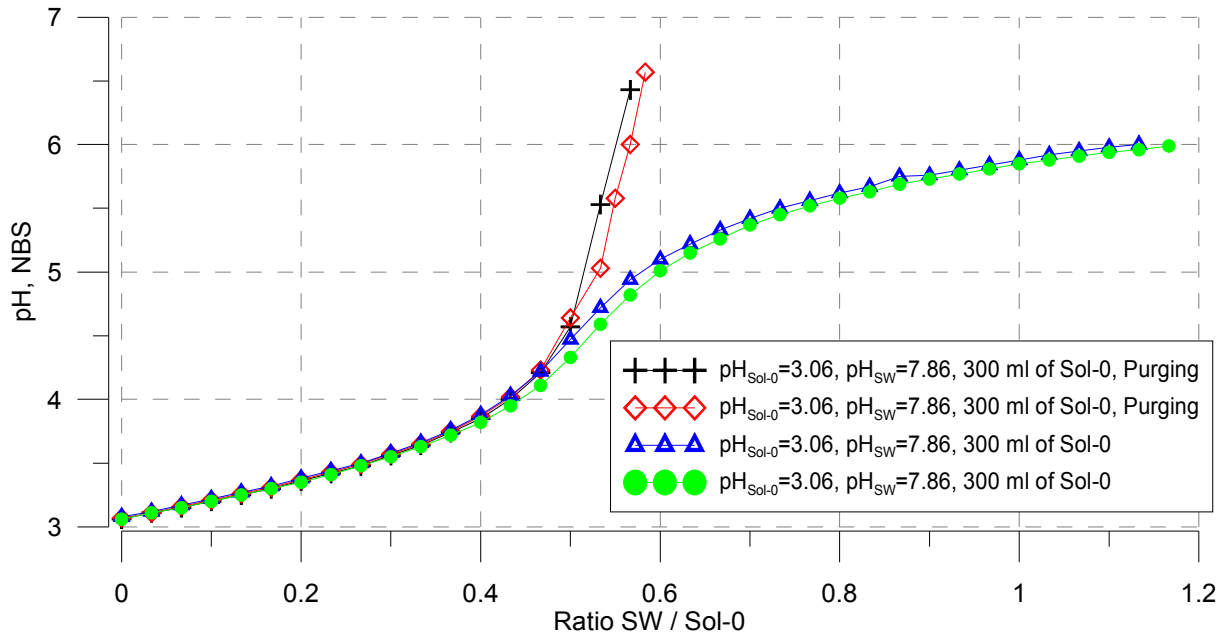

Figure 2. Ratio between the seawater (SW) and initial solution Sol-0 (1.85 mg H₂SO₄ in 1 l of the SW) necessary to reach pH=6. Titration applied for 300 ml of Sol-0 with purging and without.

The pH of this neutralized mixture solution with pH=6 was unstable. It increased from 6.03 to 6.19 in 3 hours and to more than 7.00 after 1 week. It is thus necessary to make studies directly after this solution is prepared.

The experiments above demonstrate that at pH from 4 to 5 the pH starts to increase faster with further addition of NaOH/seawater. This behaviour can be explained by the thermodynamics of the carbonate system.

Test 3. Further dilution with seawater after pH has reached 6

The SoW given for this test was:

Establish further pH – dilution relationship: Dilute the neutralized mixture (pH = 6) with more seawater to determine the relationship between dilution factor and pH in the range between pH 6 and 8. Suggested dilution factors to be measured: 1:1, 1:2, 1:3, 1:5, 1:7, 1:10, 1:20, 1:50 og 1:100. The above to be done with all parallel samples and at two temperatures.

The starting point of this test was the test solution So-0 after neutralization to pH 6 (Sol-1). The results of dilution experiment with 3 replicate samples are given in Figure 3 and Table 1. All the required dilution ratios between the SW and Sol-1 given in the SoW were included.

Table 1. Change of pH as a function of dilution factor between the SW and Sol-1

| Factor | Sample 1 | Sample 1 | Sample 1 |
|---------------|----------|----------|----------|
| 100% of Sol-1 | 6,02 | 6,03 | 6,11 |
| 100% of SW | 7,84 | 7,85 | 7,86 |
| 1 | 6,69 | 6,88 | 6,76 |
| 2 | 6,96 | 7,06 | 7,08 |
| 3 | 7,19 | 7,33 | 7,27 |
| 5 | 7,43 | 7,48 | 7,50 |
| 7 | 7,56 | 7,59 | 7,60 |
| 10 | 7,65 | 7,68 | 7,69 |
| 20 | 7,76 | 7,76 | 7,77 |
| 50 | 7,83 | 7,83 | 7,84 |
| 100 | 7,85 | 7,84 | 7,85 |

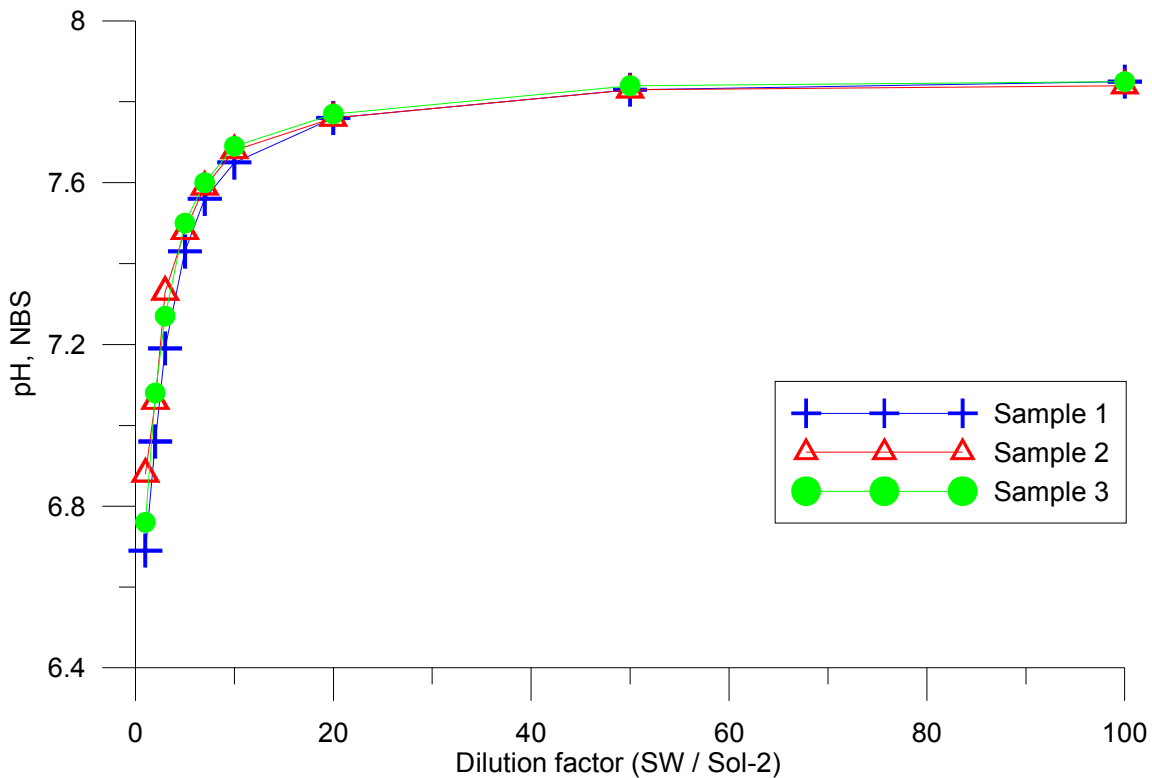

Figure 3. Change of pH as a function of dilution factor between the SW and Sol-1 (neutralized mixture with pH =6).

The low natural pH of the seawater used (7.86) does not allow us to study the whole span of values of pH from 6 to 8. A repetition of the test with the local Qatar seawater may therefore produce another curve shape, provided the natural pH of that water is higher. However, there is no reason to expect that the variability among replicate runs will be different from that shown in **Error! Reference source not found.**

Procedural protocol for tests on changes in pH of simulated Qatalum FGSWD scrubber effluents during neutralization with NaOH and/or ambient seawater

On basis of the very good correspondence between replicate runs in the above tests, they have been considered to be an adequate basis on which to build a test protocol for the Qatar experiments. The experimental protocol is given here.

Equipment

pH-meter with a combined pH electrode (with resolution 0.01 and accuracy not less than +/-0.02.

Example: ATI Orion PerpHecT Meter Model 330)

Magnetic stirrer with immersable magnet

Eppendorf Multipette Xstream manual dispenser (Figure 4) with syringes for 50 ml (2 units), 5 ml (3 units)

Calibrated pipette for 0.100 ml with tips.

Thermostat (e.g. RTE-100)

Air pump (ordinary aquarium air pump and tubing for it will do)

Tubing for air pump and the purging device

T-branch for tubing.

Glassware

2000 ml glass beakers

1000 ml glass beakers

50 ml glass beakers (2 units)

1000 ml volumetric cylinder

500 ml volumetric cylinder

1000 ml glass flask for seawater (SW) (2 units)

100 ml volumetric flask

50 ml Erlenmeyer flasks or a 50-100 ml beaker (2 units)

Washer for Distilled Water (DW)



Figure 4. Eppendorf Multipette Xstream manual dispenser with a 50 ml syringe

Reagents

Standard buffer solutions for pH meter calibration (e.g. NBS /IUPAC/NIST 4, 7, 10)

Concentrated sulphuric acid H_2SO_4

5N NaOH (Merck) solution

Distilled Water (DW)

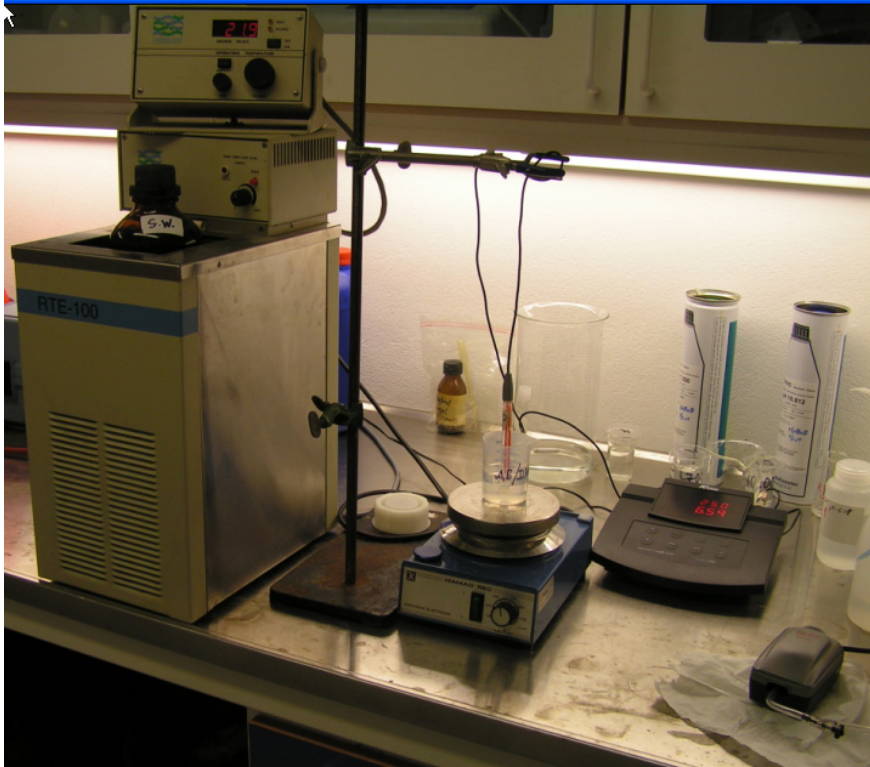
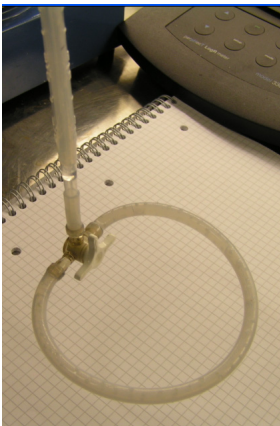

Figure 5. Thermostat, magnetic stirrer, pH meter, and air pump.

Experimental set up

The pH electrode is mounted on a laboratory stand to allow measurement of pH directly in the test beakers supplied with magnetic stirrer (Figure 5).



The calibration of the pH meters with the standard buffer solution should be made at least once a day according to the instruction for the pH meter.

To make experiments on the influence of purging with air the simplest solution is to construct an “O”-ring bubbler from a silicone hose (inner diameter about 3 mm) with holes attached to an aquarium air pump (Figure 6). The perforated ring can be immersed in the test beaker without disturbing the magnetic stirrer (Figure 8 and 9).

Figure 6. “O”-ring bubbler for air purging unit made from a silicone hose with holes (see also Figure 9)

Preparation of test sample Sol-0

Sampling and temperature adjustment of stock seawater or effluent sample.

A stock sample (minimum 10 litre volume) of the appropriate seawater to be tested should be done manually by use of clean bottles, preferably glass. These stock sample(s) should be stored refrigerated

and in darkness until use. Prior to the test 1000 ml bottles of stock should be adjusted to the required temperature in e.g. a thermostat.

Measurements of the stock sample prior to preparation of Sol-0.

Measure the pH of the stock sample to the nearest 0,01 level and take at least one 50 ml subsample for measurement of alkalinity.

Preparation of solution Sol-0.

Use a 2000 ml glass beaker supplied with a bottom magnetic stirrer. Add 1000 ml of temperature adjusted stock to the beaker with a 1000 ml volumetric cylinder. Switch on the stirrer and add 0.100 ml of concentrated H₂SO₄ carefully to the stock (use a calibrated pipette). Measure the pH. Theoretical concentration of H⁺ ions in this sample should be about 2×10^{-3} mol/l, and pH about 3 or somewhat higher depending on the seawater pH and alkalinity. This solution (**Sol-0**) is stable for several days.

Replication

To obtain an estimate of experimental variability each of the experiments described below should be repeated at least 3 times. With good laboratory practice the within experiment variability is extremely low (example in Figure 7).

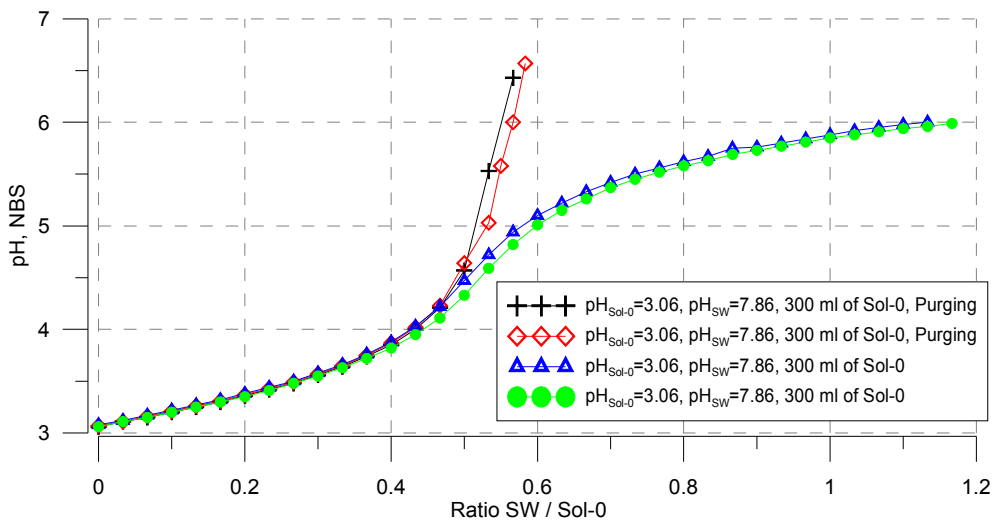

Figure 7. Example of replicate variability obtained during the NIVA pilot experiment.

Determination of the amount of NaOH required to neutralize Sol-0 to pH = 6 with and without purging with air.

Dilute 1 ml of NaOH (5N) with 100 ml DW in a volumetric flask to obtain a 0.05N solution for titration.

NaOH titration without air purging

1. Measure pH of **Sol-0** and take out subsample for analysis of alkalinity. Place a 1000 ml glass beaker on the magnetic stirrer. Add 300 ml of **Sol-0** to the beaker by use of a 500 ml volumetric cylinder. Insert the pH probe directly into the Sol-0 solution. Switch on the stirrer

and adjust to about 300 rpm. This prevents formation of bubbles which should be avoided. (Figure 8).

2. Withdraw 5 ml of the 0.05N NaOH solution into an Eppendorf Multipipette dispenser with syringe for 5 ml (or an equivalent high precision syringe) and titrate with 0.5 ml increments till pH=5.5. After each addition wait until the pH reading is stabilized before pH is recorded. After reaching pH=5.5 adjust the dispenser increment to 0.1 ml and continue to titrate until pH=6.0. Record the pH after each increment. About 6-10 ml of 0.05N NaOH is needed for the whole experiment, hence it may be necessary to refill the syringe during the titration. Take a sample for alkalinity at the end of the titration.



Figure 8. 1000 ml beaker on the magnetic stirrer with pH probe and 300 ml of **Sol-0** ready for non purged titration. Right: showing addition of NaOH.

NaOH titration with air purging

3. Establish the experimental set up as for the titration without purging. Insert the aeration system into the 1000 ml glass beaker with the perforated ring close to the bottom (Figure 9). Make sure that the ring does not disturb the stirrer. Switch on the stirrer and the air pump. Use the same stirrer rate (300 rpm). The solution shall be continuously purged during the experiment.
4. Withdraw 5 ml of the 0.05N NaOH solution into an Eppendorf Multipipette dispenser with syringe for 5 ml (or an equivalent high precision syringe) and titrate with 0.5 ml increments till pH=5.5, then change increment to 0.1 ml and continue to titrate till pH=6.0. Record the pH when stable after each increment. Take a final sample for analysis of alkalinity.

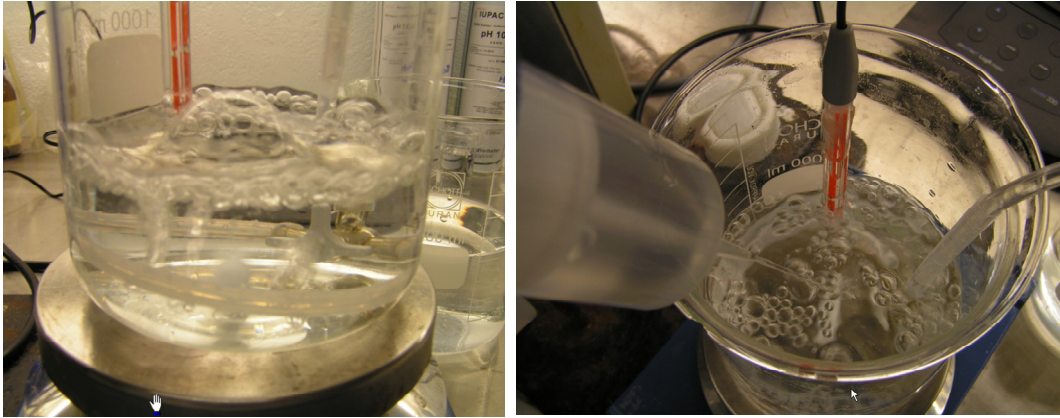

Figure 9. A 1000 ml beaker with magnetic stirrer, air purging running, pH probe and 300 ml of Sol-0 ready for titration with purging.

Determination of the amount of seawater required to neutralize the Sol-0 to pH = 6 with and without purging with air.

This test aims at determining the development in pH of the **Sol-0** during neutralization with ambient seawater or other sources of water when NaOH neutralization is not applied.

Measure the pH of the seawater (called dilution water) used for the neutralization prior to the test.

Seawater titration without air purging

5. Repeat Step 1. above.
6. Withdraw 50 ml of the dilution water into an Eppendorf Multipette dispenser with syringe for 50 ml (or an equivalent high precision pipette) and titrate with 10 ml increment till pH=5.5. After each addition wait until the pH reading is stabilized before pH is recorded. After reaching pH=5.9 adjust the dispenser increment to 5 ml and continue to titrate until pH=6.0. Record the pH after each increment. Take a sample for alkalinity at the end of the titration.

Seawater titration with air purging

7. Repeat Step 3 above.
8. Repeat Step 6 above.

Determination of pH change in the Sol-0 neutralized to pH 6 (Sol-1) during subsequent dilution with seawater

The aim of the test is to obtain data for the relationship between the change in pH and the dilution ratio during natural dilution of an effluent having pH=6 with ambient seawater. The procedure below will be the same for all end point solutions from the previous experiments (NaOH or seawater, with and without purging).

Sample a sufficient volume of ambient seawater (ca 1000 ml) in a glass bottle and store refrigerated and in darkness until use. Condition the seawater to the test temperature prior to the experiment.

Prepare min 500 ml of **Sol-0** and neutralize to pH=6 according to either step 1 and 2 (NaOH, no purging), 3 and 4 (NaOH with purging), 4 and 6 (seawater, no purging) or 7 and 8 (seawater and purging) above. This solution, called **Sol-1**, should be used within 2 hours of preparation.

Place a 50 ml Erlenmeyer flask or a 50-100 ml beaker equipped with a magnetic stirrer at the stirrer table. Add exactly 30 ml of **Sol-1** to the flask by use of the Eppendorf Xstream dispenser with a 50 ml syringe. Switch on the stirrer and adjust speed so that bubble formation is avoided (300 turns/minute). Insert the pH electrode into the **Sol-1** and record the pH when stable.

Repeat the procedure with 30 ml of the ambient seawater alone.

Subsequently repeat the procedure with mixtures of **Sol-1** and seawater according to the Table 2 below. Use a separate 50 ml syringe for **Sol-1** and for seawater.

Table 2. Volumes of Sol-1 and ambient seawater for the pH - dilution relationship establishment.

| Mixing factor | Sol-1 (pH=6), ml | SW, ml |
|---------------|------------------|--------|
| - | 30 | - |
| - | - | 30 |
| 1 | 15 | 15 |
| 2 | 10 | 20 |
| 3 | 10 | 30 |
| 5 | 5 | 25 |
| 7 | 5 | 35 |
| 10 | 2,5 | 25 |
| 20 | 2 | 40 |
| 50 | 1 | 50 |
| 100 | 0,5 | 50 |

Appendix C. The ESC neutralization/dilution experiments

Background

On contract from Qatalum the Environmental Studies centre (ESC), at Qatar University, Doha has performed a series of neutralization and dilution experiments by use of the NIVA protocol presented in Appendix A to this report. The experiments utilized seawater samples from 5 different locations in the Qatalum seawater intake channel and outside the industrial site (Figure 1). These samples were used both for preparing the simulated acidic scrubber effluent for testing and in the dilution experiments with seawater. The following is an outline of the experiments prepared by NIVA on basis of e-mail correspondence between Qatalum and ESC and on the test results submitted to NIVA in the form of in EXCEL worksheets.

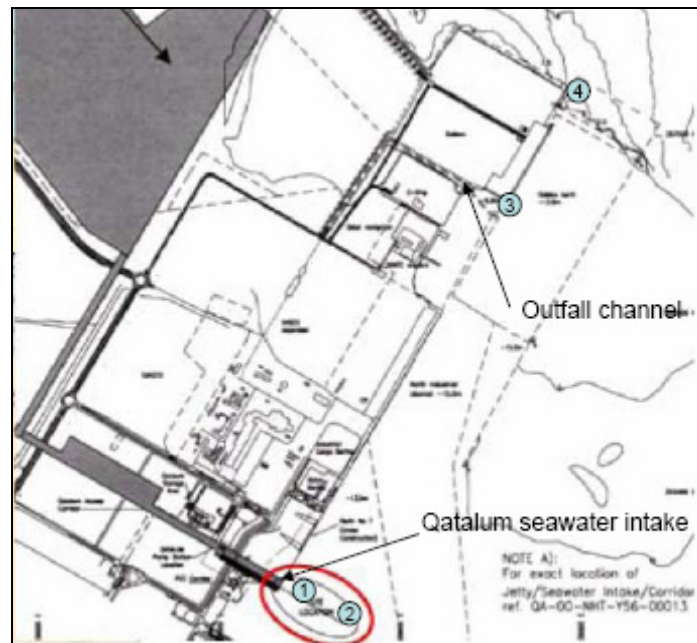

Figure 1. Sampling points for seawater samples for the ESC experiments. Location 5 is within the Qatalum seawater intake.

Technical performance

The seawater samples were taken by Qatalum. One sample was taken from each site and brought immediately to the ESC laboratory. The sample used from site 4 (the MIC channel bridge) was taken at the surface, the others at 2 m depth. Details of the sampling and sample characterization is given in Table 1. The experiments were done according to the NIVA protocol.

Table 1. Sampling locations and sample description for the seawater samples used in the ESC experiments.

| Ambient Readings done by Qatalum Personnel using Hach pH Meter | | | | | | | Readings performed at ESC as per submitted samples using YSI Environmental pH Meter. | | | |
|--|-------------------------|----------------|-----------|---------------|-------|------------|--|-----------|-------------|------|
| Location No. | Location Name | Coordinates | Type | Sampling Time | | Parameters | | Type | Temp. (°C)* | pH |
| | | | | Start | End | pH | Temp. (°C) | | | |
| 1 | Location 1 | 24° 57' 36.0"N | Surface | 10:00 | 10:24 | 8,26 | 26,71 | 2-m Depth | 19,5 | 8,19 |
| | | 51° 35' 47.1"E | 2-m Depth | | | 8,31 | 23,8 | | 34,6 | 8,03 |
| 2 | Location 2 | 24° 57' 37.6"N | Surface | 10:34 | 10:40 | 8,25 | 27,4 | 2-m Depth | 19,8 | 8,17 |
| | | 51° 35' 51.2"E | 2-m Depth | | | 8,28 | 23,6 | | 34,6 | 8,00 |
| 3 | Location 3 | 24° 57' 40.5"N | Surface | 10:43 | 10:50 | 8,26 | 25,6 | 2-m Depth | 19,5 | 8,15 |
| | | 51° 35' 53.2"E | 2-m Depth | | | 8,28 | 24,2 | | 34,8 | 8,03 |
| 4 | MIC Channel (bridge) | | Surface | 12,24 | | 8,24 | 29,8 | Surface | 19,4 | 8,19 |
| | | | 2-m Depth | | | | | | 34,7 | 8,04 |
| 5 | Qatalum Seawater Intake | 24° 57' 30.6"N | Surface | 11:10 | 11:30 | 8,3 | 24,8 | 2-m Depth | 19,8 | 8,16 |
| | | 51° 35' 13.4"E | 2-m Depth | | | 8,29 | 23,4 | | 34,5 | 8,01 |

Main results

The main results are only presented as graphs.

A

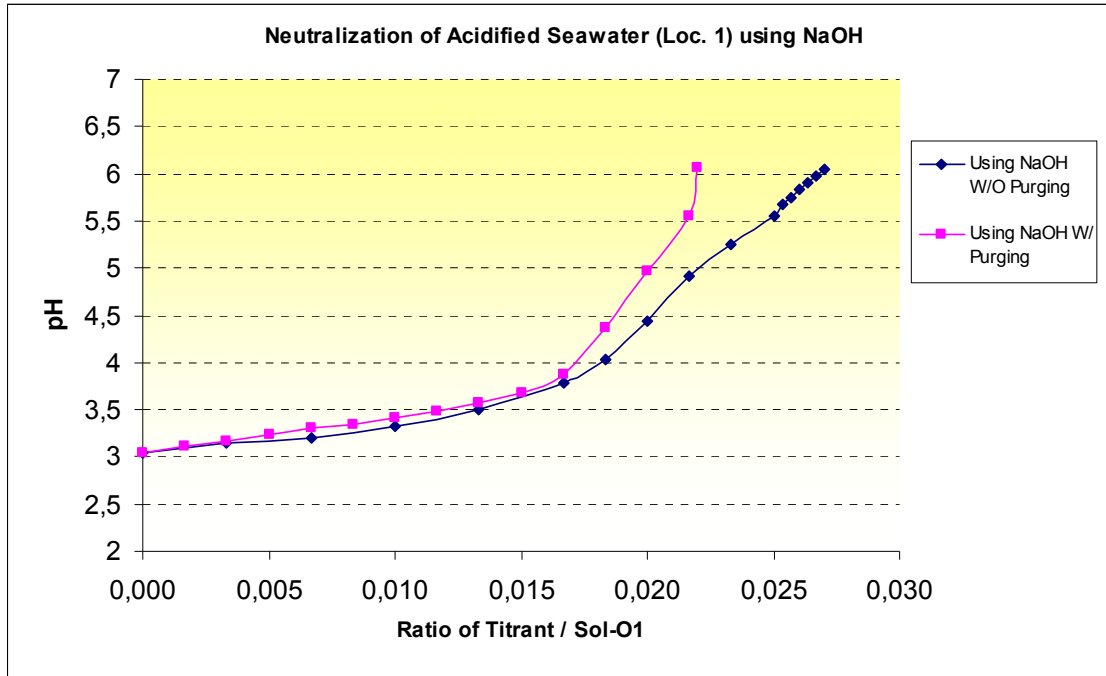

B

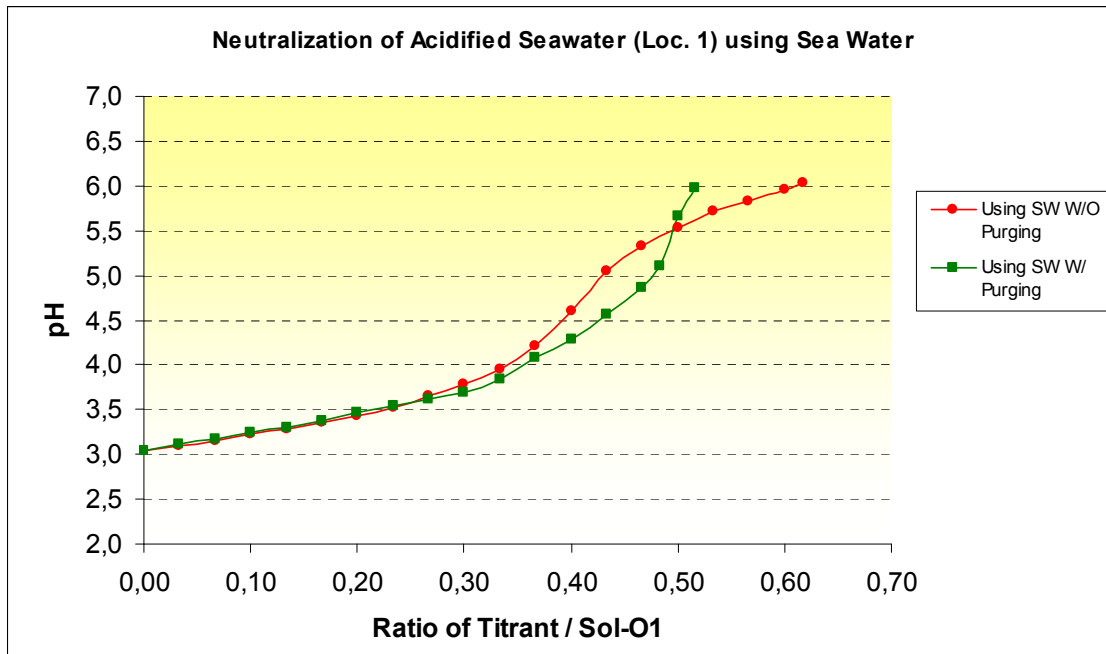
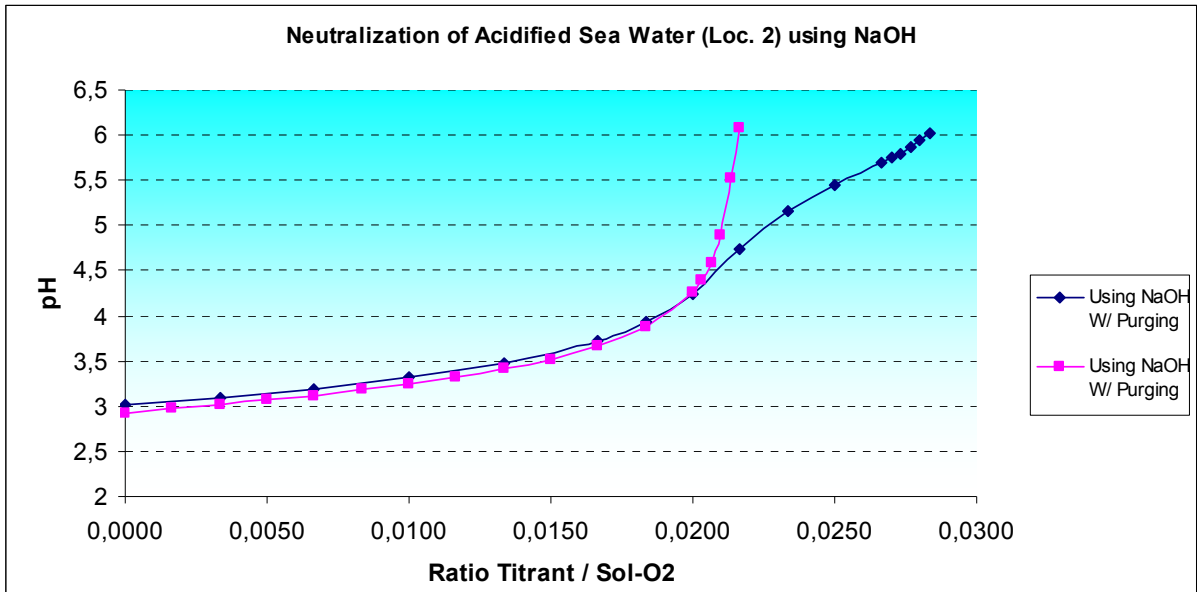

Figure 2. Seawater from Location 1 acidified to pH=3 (Sol-O1) and neutralized with NaOH (A) and seawater (B) to pH=6 with and without simultaneous air purging.

A



B

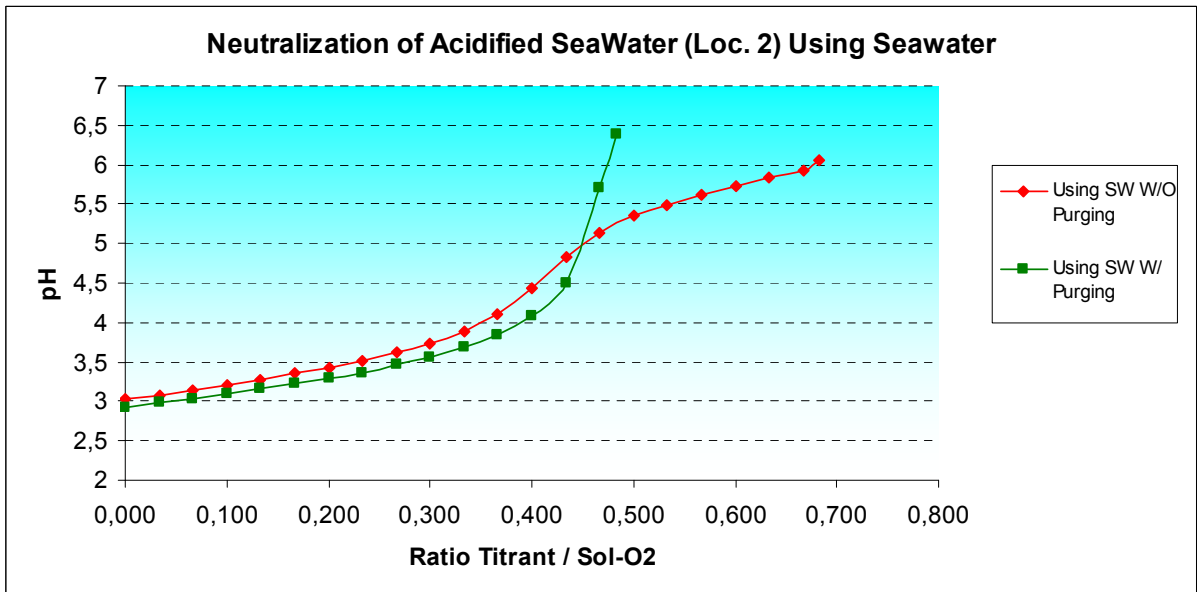
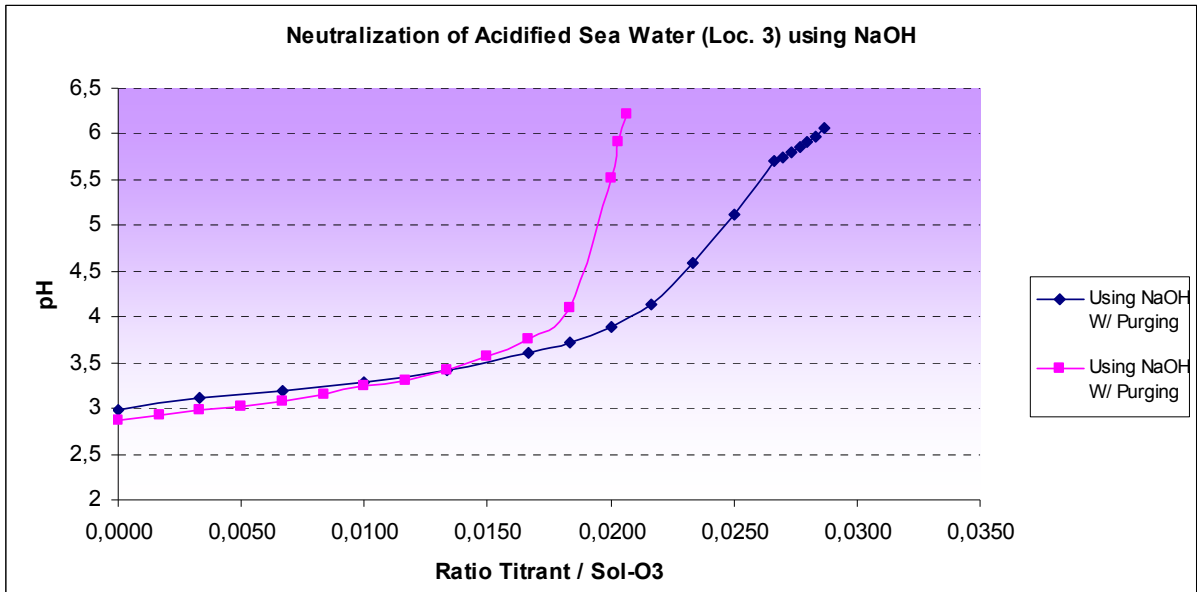

Figure 3. Seawater from Location 2 acidified to pH=3 (Sol-O2) and neutralized with NaOH (A) and seawater (B) to pH=6 with and without simultaneous air purging.

A



B

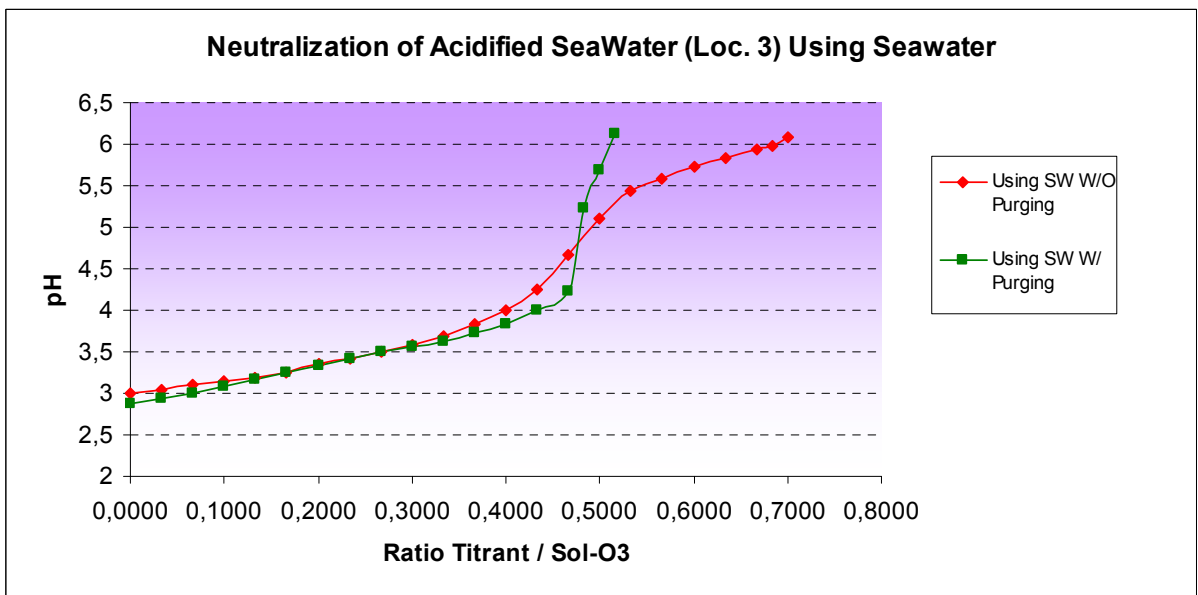
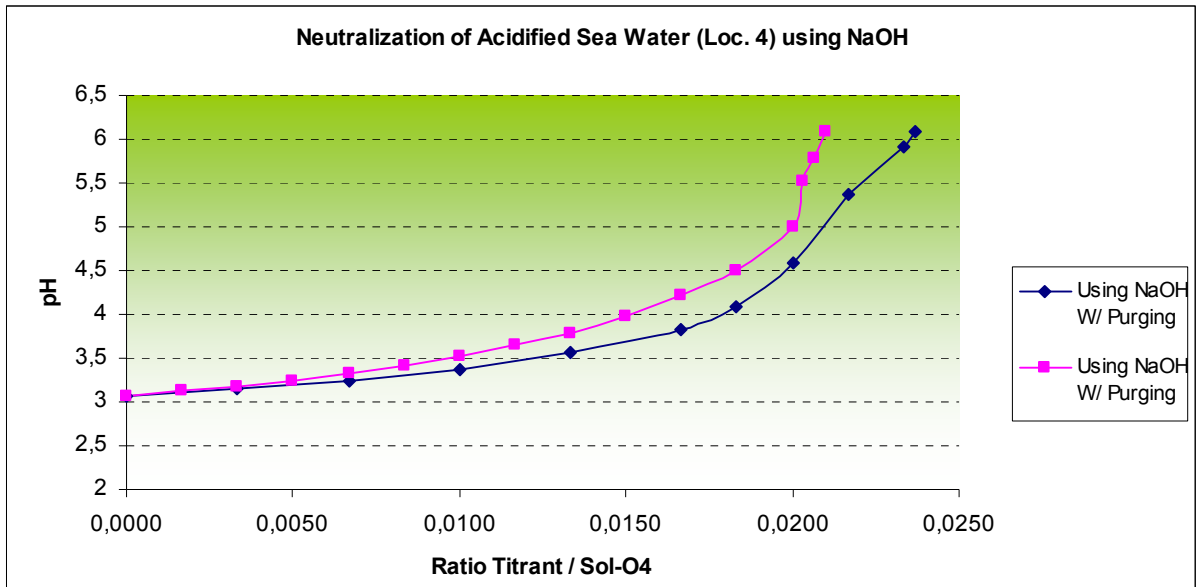

Figure 4. Seawater from Location 3 acidified to pH=3 (Sol-O3) and neutralized with NaOH (A) and seawater (B) to pH=6 with and without simultaneous air purging.

A



B

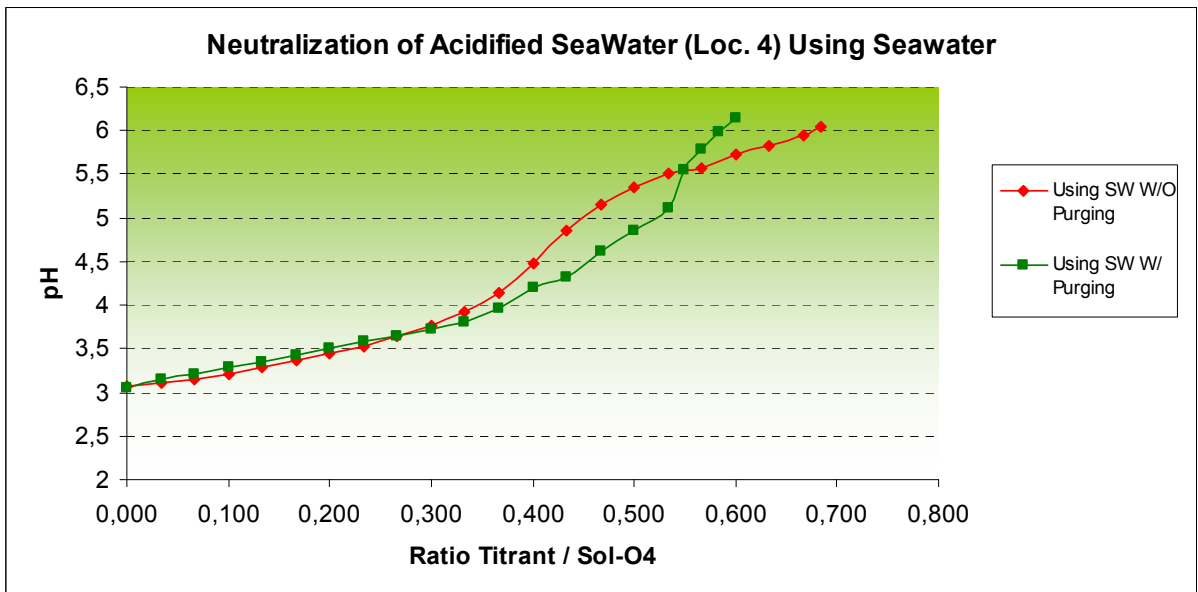
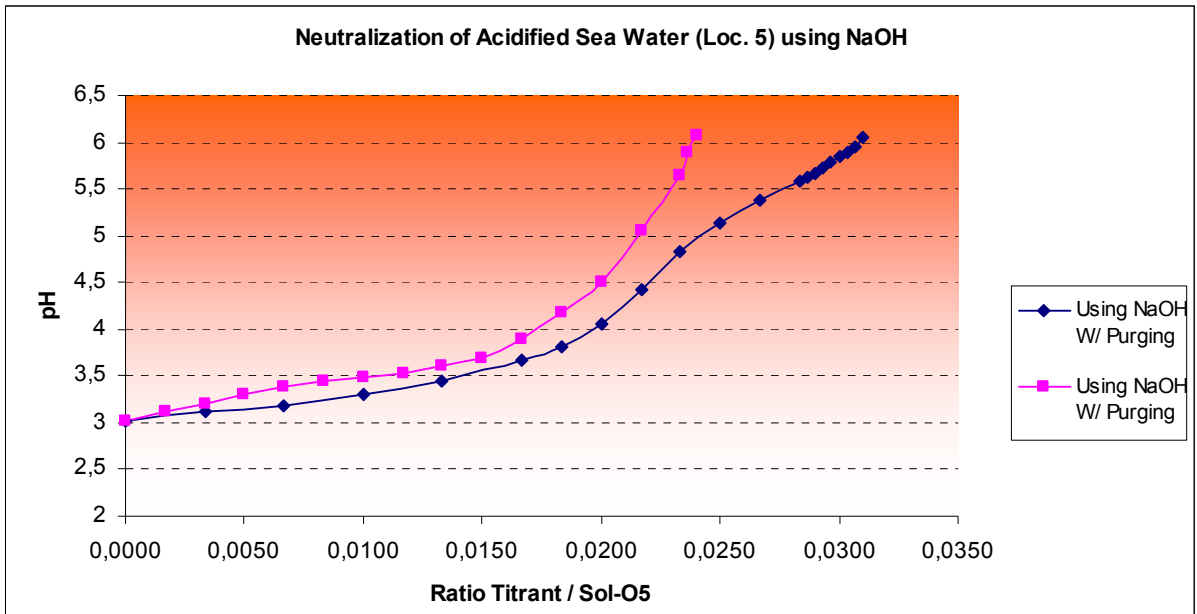

Figure 5. Seawater from Location 4 acidified to pH=3 (Sol-O4) and neutralized with NaOH (A) and seawater (B) to pH=6 with and without simultaneous air purging.

A



B

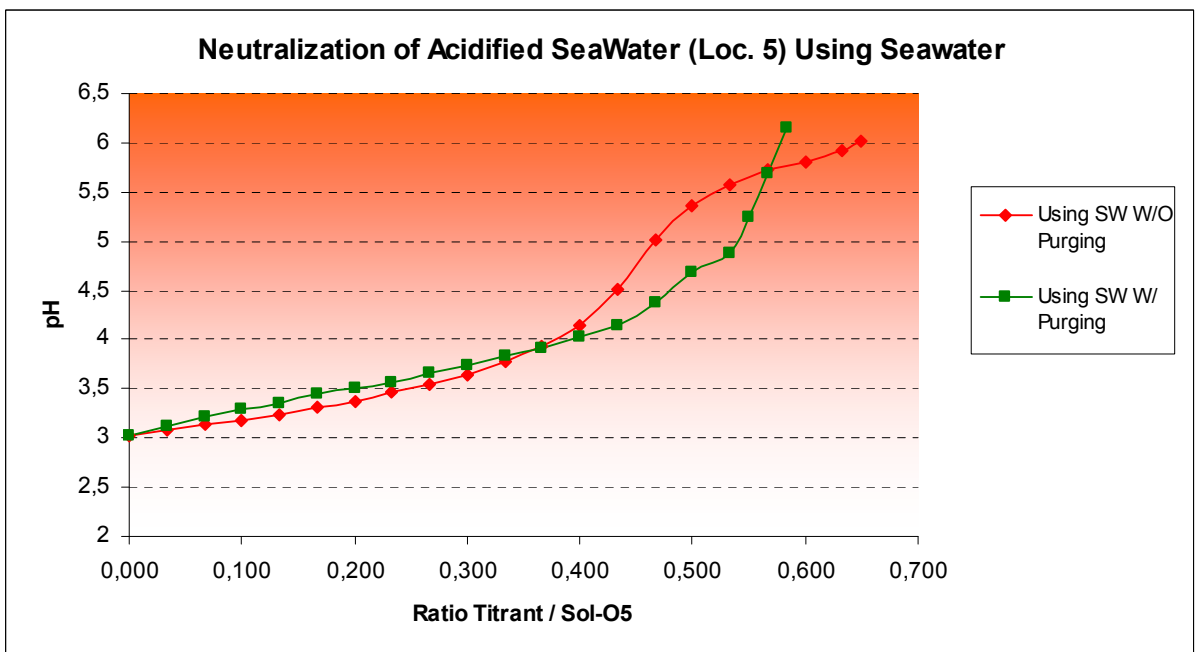
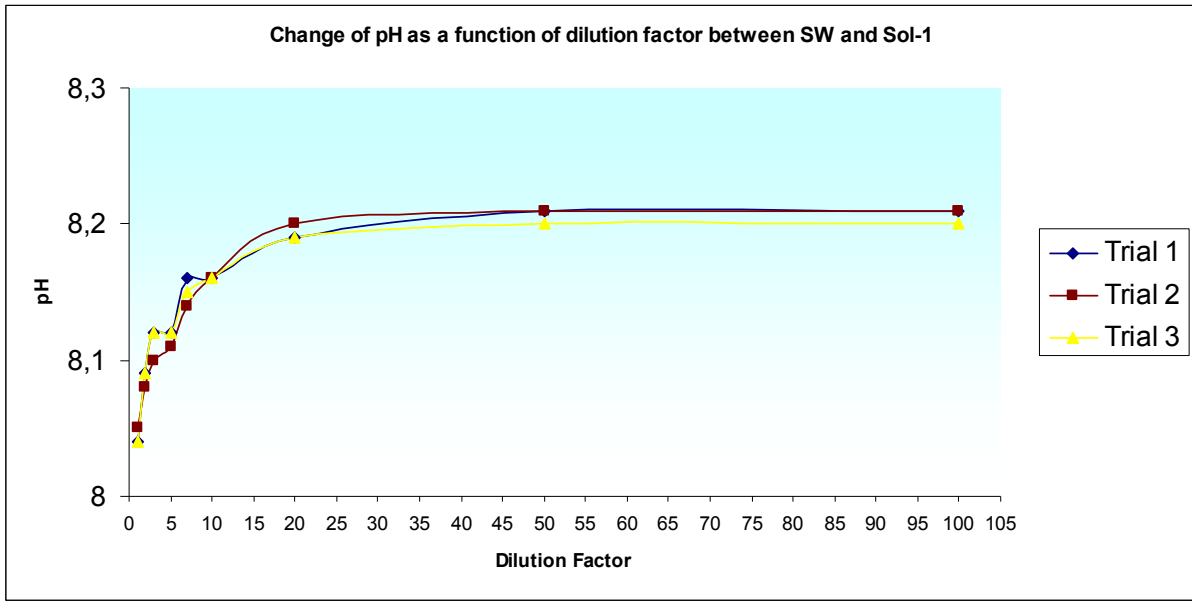

Figure 6. Seawater from Location 5 acidified to pH=3 (Sol-O5) and neutralized with NaOH (A) and seawater (B) to pH=6 with and without simultaneous air purging.

A



B

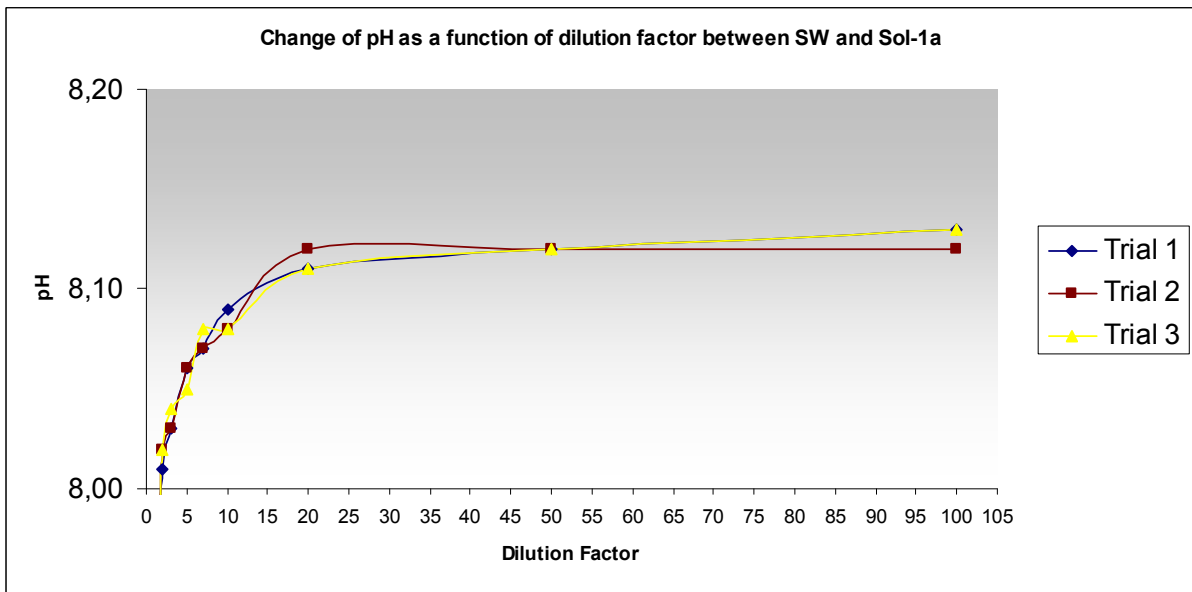

Figure 7. Change in pH of an artificially made and neutralized (to pH=6) scrubber effluent during continued dilution with seawater. The starting test solution in A is the end solution shown in Figure 1A with air purging. The starting solution in B is the end solution shown in Figure 1B with air purging. Each dilution experiment was done in triplicate. These results are also shown in Table 2.

Table 2. Dilution factors and resulting pH change in the ESC experiments simulating the ambient dilution of an effluent with pH=6 after neutralization. The results are also shown in Figure 7.

| Volumes of Sol-1(NaOH) and ambient SeaWater for pH - dilution relationship establishment | | | | | |
|---|------------------------|--------|------------|------------|------------|
| Location 3 : Acidified seawater neutralized with NaoH (Sol-1) with purging with air. | | | | | |
| Dilution Factor | *Sol-1 (pH = 6.22), mL | SW, mL | pH, Trial1 | pH, Trial2 | pH, Trial3 |
| 0 | 30 | | 6,22 | 6,22 | 6,22 |
| 0 | | 30 | 8,23 | 8,23 | 8,23 |
| 1 | 15 | 15 | 8,04 | 8,05 | 8,04 |
| 2 | 10 | 20 | 8,09 | 8,08 | 8,09 |
| 3 | 10 | 30 | 8,12 | 8,10 | 8,12 |
| 5 | 5 | 25 | 8,12 | 8,11 | 8,12 |
| 7 | 5 | 35 | 8,16 | 8,14 | 8,15 |
| 10 | 2,5 | 25 | 8,16 | 8,16 | 8,16 |
| 20 | 2 | 40 | 8,19 | 8,20 | 8,19 |
| 50 | 1 | 50 | 8,21 | 8,21 | 8,20 |
| 100 | 0,5 | 50 | 8,21 | 8,21 | 8,20 |

| Volumes of Sol-1a(Sea Water) and ambient SeaWater for pH - dilution relationship establishment | | | | | |
|---|-------------------------|--------|------------|------------|------------|
| Location 2 : Acidified seawater neutralized with Sea Water (Sol-1a) with purging with air. | | | | | |
| Dilution Factor | *Sol-1a (pH = 6.38), mL | SW, mL | pH, Trial1 | pH, Trial2 | pH, Trial3 |
| 0 | 30 | | 6,38 | 6,38 | 6,38 |
| 0 | | 30 | 8,22 | 8,22 | 8,22 |
| 1 | 15 | 15 | 7,90 | 7,91 | 7,90 |
| 2 | 10 | 20 | 8,01 | 8,02 | 8,02 |
| 3 | 10 | 30 | 8,03 | 8,03 | 8,04 |
| 5 | 5 | 25 | 8,06 | 8,06 | 8,05 |
| 7 | 5 | 35 | 8,07 | 8,07 | 8,08 |
| 10 | 2,5 | 25 | 8,09 | 8,08 | 8,08 |
| 20 | 2 | 40 | 8,11 | 8,12 | 8,11 |
| 50 | 1 | 50 | 8,12 | 8,12 | 8,12 |
| 100 | 0,5 | 50 | 8,13 | 8,12 | 8,13 |

Appendix D. Effluent and environmental monitoring

1. Introduction

As part of the contract for the environmental impact assessment for the Qatalum seawater scrubber effluent, NIVA has been requested to assess the adequacy of the Qatar Steel baseline study performed by URS Qatar LLC as a reference for future environmental monitoring in connection to the Qatalum effluent to the sea, and if needed propose supplementary baseline studies. NIVA was also asked to develop the outline of a program for follow up environmental monitoring to be implemented at the Qatalum site. These issues are treated in the present Appendix.

2. The URS Baseline Survey (2008)

2.1. Scope and parameters

The objective of this survey has been to determine the baseline physical, chemical and biological properties of the local marine environment outside the Mesaieed Industrial City (MIC) and identify any sensitive receptors in the vicinity of the MIC channel outlet. Various laboratories have been involved in the analysis and the environmental parameters covered are listed in the table below (from the URS report).

The physical and chemical seawater parameters covered (see table below) are appropriate and form a good baseline. In addition to those listed in the table below, the survey also covered one month continuous logging of tide and currents. Based on general experience the results for some of the parameters are considered to be less reliable than others, e.g. COD which is difficult to measure in seawater, and possibly levels of PAH. Analysis of PAH in seawater at background level requires extraction of fairly large water samples, e.g. 5 litres, and although 5l Niskin samplers were applied it is not clear if the total volume was used for the PAH analysis.

In addition to the parameters included we recommend that supplementary measurement of ambient alkalinity in water samples is performed since reduced alkalinity is a typical near zone feature of scrubber effluents. One should also clarify the discrepancy between the URS results showing lower ambient pH than other local studies.

The URS sediment survey covers both parameters that should be included in a future monitoring program and parameters that may be omitted since they are not expected to be linked to the Qatalum effluent. Hence, PCBs, BTEX and TPH may be omitted. We expect that analysis of sediment PAH will be sufficient for tracing any hydrocarbon input of concern from the Qatalum effluent.

The biological survey covered zooplankton, benthic epifauna and flora (from SCUBA video recordings) and sediment infauna. In addition the analysis of chlorophyll *a* gives an estimate of the biomass of active phytoplankton in the water column. We consider these surveys to be adequate for the baseline purpose. The zooplankton data may be considered to be semi quantitative provided the water volume passing through the plankton net is estimated. The epifauna/flora data must be considered to be qualitative, whereas the infauna data are quantitative since taken from a fixed size area. Quantitative registration facilitates comparison of biological features over space and time. In a follow up monitoring program one should consider applying quantitative registration of epifauna/flora by use of a fixed area frame approach done by SCUBA divers.

Table 1-1: Survey Sampling Regime and Analysis Conducted for Sediment and Seawater Samples for each Survey Station

| Seawater Quality and Physical Chemistry | Sediment Quality | Underwater Observations |
|--|--|---|
| <p>Field (in -situ) Measurements</p> <ul style="list-style-type: none"> • Water depth • pH • Salinity • Conductivity • Temperature • Dissolved Oxygen (DO) • % Oxygen Saturation • Total Dissolved Solids (TDS) <p>GL</p> <ul style="list-style-type: none"> • Benzene Toluene Ethylbenzene (BTEX) • Polycyclic Aromatic Hydrocarbons (PAH) • Metals (Al, S, Ba, Cd, Co, Cr, Cu, Fe, Hg, Mn, Ni, Pb, Sn, Se, As, V, and Zn) | <p>GL</p> <ul style="list-style-type: none"> • Elements & Metals (Al, S, Ba, Cd, Co, Cr, Cu, Fe, Hg, Mn, Ni, Pb, Sn, Se, As, V, and Zn) ; • Total Petroleum Hydrocarbon (TPH); • BTEX; • Polychlorinated Biphenyls (PCBs), including Aroclor 1016, 1221, 1232, 1242, 1248, 1254, and 1260; and • PAH <p>ESC</p> <ul style="list-style-type: none"> • Particle Size Analysis (PSA) • Total Organic Matter (TOM) • Carbonate Content | <p>Videography of seabed</p> <ul style="list-style-type: none"> • Characterization of Seafloor • Epibenthic biota (descriptions) |
| <p>ESC</p> <ul style="list-style-type: none"> • Total Suspended Solids (TSS) • Oil & Grease • Biological Oxygen Demand After 5 Days (BOD5) • Chemical Oxygen Demand (COD) • Chlorophyll a <p>Zooplankton – URS</p> <ul style="list-style-type: none"> • Identification to lowest possible taxonomic level • Calculation of biomass | <p>SGS</p> <ul style="list-style-type: none"> • Radioactivity <p>Benthic Infauna – URS</p> <ul style="list-style-type: none"> • Extraction and Identification to lowest taxonomic level possible <p>Statistical analysis on biodiversity, species richness and evenness</p> | |

2.2. Sample stations

The URS survey covered 11 stations at increasing distance south and east of the MIC channel including one reference station to the north-east (Figure 1). One station is in the MIC channel and 3 stations cover the very near zone just outside this. Stations 6 – 9 cover the conditions in the shipping channel, whereas station 10 describes the conditions at the eastern border of this channel. The stations appear adequate to describe the basic conditions within the expected impact zone from the Qatalum effluent (cf Figure 11 in the main report). Ideally the geographical coverage should be widened somewhat towards the north, but there is no reason to expect that the baseline conditions there deviate systematically from that which has been described at stations 6 to 10.

The point samples of water were taken at 3 different depths (surface, mid water, and bottom), except for the shallowest stations close to the MIC channel. Together with the continuous vertical profiles generated for the typical hydrographical and hydrochemical parameters the results ought to give an adequate picture of the water column conditions.



Figure 1. Map of URS baseline survey sampling stations (from URS 2008).

2.3 Timing

Three sampling campaigns were completed by URS, all in July 2008 and at different times of the day. The vertical profiles have only been logged once. Currents and tide were logged for a period of 1 month. This does not allow any seasonal trends to be described. Other studies described in Atkins (2006) provide information on the seasonal variability in e.g. currents and hydrography (cf Figure 5 in main report Chapter 3.3). Together these studies provide a picture of the local baseline seasonal dynamics sufficient for later monitoring. Furthermore, since Qatalum is in operation it will not be possible to generate more baseline information on local hydrographical and hydrochemical conditions

in the potential impact zone. In the monitoring program the near zone conditions must therefore be assessed against both the baseline data available and conditions at appropriate reference sites.

2.4 Procedures of analysis

Apparently the *in situ* logging has been performed with state-of-the-art methods and equipment. The analytical laboratories have mostly applied recommended US EPA procedures which should be well tested and reliable. Analysis of oil and grease has apparently been done by gravimetry. This may be appropriate to log levels in industrial effluents, but not sensitive enough to show levels of oil hydrocarbons in the seawater of the recipient. The latter demands either analysis based on UV fluorescence or even better by GC/FID.

The analysis of sediment fauna also seems to be state-of-the-art including the use of the statistical package PRIMER for data analysis. Species identification from video recordings is always uncertain and relies entirely on the taxonomic competence of the investigators. During later monitoring of epibenthic organisms one should use fixed area frames and a combination of *in-situ* identification and sampling of selected individuals for species verification in the laboratory.

3. Proposal for a future effluent and environmental monitoring program

3.1. Purpose

The environmental monitoring program will have the following purpose:

1. Identify any environmental impact from the overall effluent to the sea when the Qatalum installation has reached regular operation.
2. Control that the effluent complies with relevant discharge limits.
3. Control that compliance with the EQS values for parameters of concern is obtained within the geographical impact zone predicted in the present EIA.

The results should also be used to establish if there is a systematic relationship between pH and alkalinity and how this might vary with distance from the MIC outlet. If such a relationship is established, the pH logging during the long term program may be used as a proxy for alkalinity.

3.2. Program outline

The Qatar MoE requests that a survey to achieve purpose 1 is performed during a maximum 3 months period when Qatalum is fully operational. Purpose 2 and 3 shall be covered by a longer term control programme.

3.2.1. The 3 months survey

Any effects of the discharges are expected to be subtle and should be assessed on basis of deviations from the baseline conditions described primarily in the URS 2008 survey. The study elements included in the 3 months survey should therefore as much as possible follow the design of the corresponding elements in the URS survey.

Timing

The time it takes before any environmental impacts are manifested and likely to be detected varies. Impact on the water column physical and chemical properties is immediate, whereas impact on local benthic organisms may occur gradually. In particular one must expect that any ecosystem effects only

appear after a long exposure time. It is therefore important that a sufficient period of normal operation precedes the survey. We envisage that one should allow at least one year of normal operation before the survey is made.

Since the most important comparison will be with the baseline survey performed by URS in 2008 the survey should be performed in the same season, i.e. during July or as close to that as possible. Number of measurement campaigns for each parameter is given in Table 1.

Survey elements

The recommended survey elements are given in Table 1. Sampling methods, sample treatment and analytical procedures should be the same as in the URS survey. Vertical profiles should be logged by use of electrodes lowered from the surface to the bottom. Samples for percent fine sediment (<63 µm) and TOC may either be taken as subsamples from the infauna grab samples or as separate core samples.

Sampling design

The sampling/measurement stations should be placed according to Figure 1. Six of the URS stations are included in this design. The video transect for seagrass and epifauna should run from station 8 to station 10 as in the URS survey.

Follow up surveys

If the above survey detects any environmental impact of concern, it is recommended that a follow up programme is tailored to the following purpose.

- Verify whether the impact found is real or not
- Monitor changes in the impact pattern (increase or recovery) over time.

Table 1. Proposed sampling design for the 3 months survey.

| Target | Study element | Stations | Depth | Frequency (day no) |
|-------------------|----------------------|----------------|-------------------|--------------------|
| Water column | Temperature | All | Vertical profile | 1, 30, 60 |
| | Salinity | All | As above | 1, 30, 60 |
| | Dissolved oxygen | All | As above | 1, 30, 60 |
| | pH | All | As above | 1, 30, 60 |
| | Alkalinity | All | Surf, mid, bottom | 1, 30, 60 |
| | FRC | 4, 6, 9, 13, R | As above | 1, 30, 60 |
| | Tot susp. Solids | All | As above | 1, 30, 60 |
| Bottom sediments | Chlorophyll <i>a</i> | 6, 8, 13, 14 | As above | 1, 30, 60 |
| | % <63 mm grain | 8, 9, 10, 11 | Sediment 0-5 cm | once |
| | TOC | 8, 9, 10, 11 | As above | once |
| Benthic organisms | Sediment infauna | 8, 9, 10, 11 | Grab depth | once |
| | Seagrass | Video transect | Seabed surface | 1, 60 |
| | Epifauna | Video transect | As above | 1, 60 |

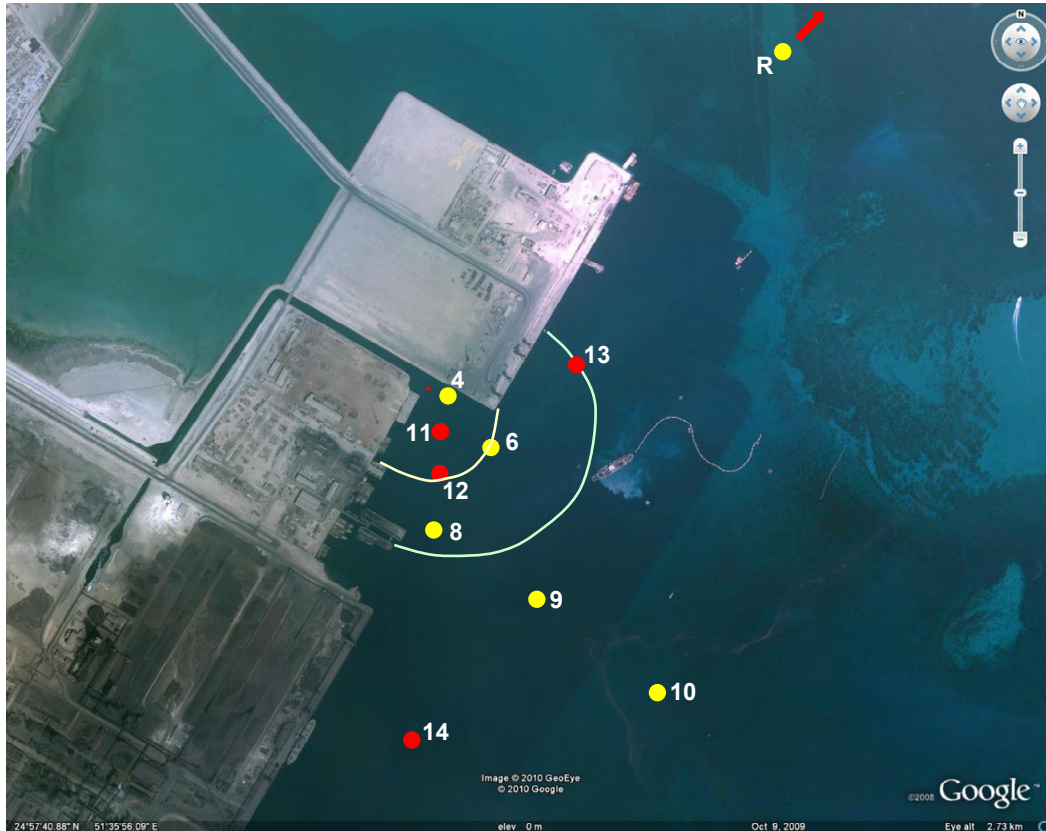

Figure 1. Suggested station positions for the 3 months survey. The URS stations included are shown in yellow with original station id-number, including the reference station (R). New stations are numbered from 11 and upward to avoid confusion with the other URS stations. Isolines describe the 250 m and 500 m distance from the discharge point.

3.2.2. Long term control program

This program should fulfil 2 purposes:

- Control that the levels of the elements of concern do not exceed the estimated levels at the discharge point to the sea as given in Table 8A of the main report for regular operational conditions. The same purpose is valid if a Case 1B or Case 2 occurs. As reference against which to assess these results, corresponding measurements should be made simultaneously in the Qatalum seawater intake.
- Control that the levels of the elements of concern do not exceed the proposed EQS values given in e.g. Table 8, outside an expected impact zone within 250 m distance from the discharge point.

Details of this control programme are given in Table 2. Logging of temperature, salinity, dissolved oxygen and pH should be made by electrodes. In the seawater intake and MIC channel outlet the logging should be made for a period of 10 minutes at one position.

Alkalinity, FRC and sulphide cannot be measured *in situ*, but requires laboratory analyses on water samples. This enhances the complexity of the field programme. We recommend that sulphide and FRC is included only if these elements are present in significant concentrations in the effluent (i.e. above

0,1 and 0,05 mg/l respectively) at discharge to the sea. Alkalinity should also be included only if a relationship between pH and alkalinity cannot be established in the 3 months survey.

The proposed programme should be executed for one calendar year (i.e. 4 campaigns). After that one should evaluate if there is a need for continued monitoring.

Table 2. Proposed design for the long term control program

| Target | Study element | Stations | Depth | Frequency |
|-----------------------|------------------|--|-------------------|--------------------|
| Effluent from MIC | Temperature | Seawater intake and MIC channel outlet | Mid channel | As required by MoE |
| | Salinity | As above | As above | As above |
| | Dissolved oxygen | As above | As above | As above |
| | pH | As above | As above | As above |
| | Alkalinity 1) | As above | As above | As above |
| | Sulphide 2) | As above | As above | As above |
| | FRC 2) | As above | As above | As above |
| Recipient impact zone | Temperature | 4, 6, 8, 11, 12, 13 in Figure 1 | Vertical profile | Every 3 months |
| | Salinity | As above | As above | As above |
| | Dissolved oxygen | As above | As above | As above |
| | pH | As above | As above | As above |
| | Alkalinity 1) | As above | Surf, mid, bottom | As above |
| | FRC 2) | As above | As above | As above |
| | Sulphide 2) | As above | As above | As above |

- 1) May be excluded if a systematic relationship between pH and alkalinity is established in the 3 months program.
- 2) Should be excluded if sulphide < 0,1 mg/l and FRC < 0,05 mg/l in the effluent at discharge.

NIVA: Norway's leading centre of competence in aquatic environments

NIVA provides government, business and the public with a basis for preferred water management through its contracted research, reports and development work. A characteristic of NIVA is its broad scope of professional disciplines and extensive contact network in Norway and abroad. Our solid professionalism, interdisciplinary working methods and holistic approach are key elements that make us an excellent advisor for government and society.



Norwegian Institute for Water Research

Gaustadalléen 21 • NO-0349 Oslo, Norway
Telephone: +47 22 18 51 00 • Fax: 22 18 52 00
www.niva.no • post@niva.no